



Nabco Entrances Inc. S82 W18717 Gemini Drive Muskego, Wisconsin 53150  
Phone: (877) 622-2694 Fax: (888) 679-3319 www.nabcoentrances.com  
NABCO hours of Operation: Monday to Friday 8:00 a.m.- 4:30 p.m. (Central Time)

*Associated Manuals Part Numbers: Opus Control Wiring and Programming QSPG; P/N C-00139  
GT Swing Door Owner's Manual; P/N C-00110 (for Decal Installation)  
NABCO Price Book P/N 16-9244-30 (for Sensors, Switches, and Accessories)*

**WARNING**

- Turn OFF all power to the Automatic Door if a Safety System is not working.
- Instruct the Owner to keep all power turned OFF until corrective action can be achieved by a NABCO trained technician. Failure to follow these practices may result in serious consequences.
- NEVER leave a Door operating without all Safety detection systems operational.

**Table of Contents**

<b>CHAPTER 1: WARNING LABELS</b>	<b>3</b>
<b>CHAPTER 2: GENERAL SAFETY RECOMMENDATIONS</b>	<b>3</b>
<b>CHAPTER 3: SCOPE</b>	<b>4</b>
SECTION 3.1: To the Installer	4
SECTION 3.2: Objective	4
<b>CHAPTER 4: GETTING STARTED</b>	<b>4</b>
SECTION 4.1: Mechanical Configurations	4
SECTION 4.2: Electrical Standards	4
SECTION 4.3: Installation Specifications	5
SECTION 4.4: Base Unit Types	5
SECTION 4.5: Swing Door Types	5
SECTION 4.6: Header Types	5
<b>CHAPTER 5: INSTALL THE BOTTOM LOAD HEADER</b>	<b>6</b>
SECTION 5.1: Measure Distance Between Door and Building Wall	7
SECTION 5.2: Prepare the Header	7
SECTION 5.3: Install the Bottom Load Header onto Door Frame	7
SECTION 5.4: Install Bottom Load Components	8
<b>CHAPTER 6: INSTALL THE SIDE LOAD HEADER</b>	<b>11</b>
SECTION 6.1: Before Installing the Header	12
SECTION 6.2: Secure the Side Load Header to Door Frame	12
<b>CHAPTER 7: INSTALL THE PANIC LATCH (IN SWING DOORS ONLY)</b>	<b>13</b>
<b>CHAPTER 8: 120 VAC GENERAL WIRING</b>	<b>15</b>

**CHAPTER 9: HANDING ..... 16**  
SECTION 9.1: How to Determine Handing .....16  
SECTION 9.2: Install the Handing Harness .....17

**CHAPTER 10: INSTALL THE OUTSWING ARM ..... 17**  
SECTION 10.1: Prep the Swing Door .....17  
SECTION 10.2: Prep the Outswing Arm Assembly .....18  
SECTION 10.3: Secure the Arm Shoe to the Swing Door .....19  
SECTION 10.4: Set Pre-Load .....19  
SECTION 10.5: Secure the Outswing Arm to Door .....20

**CHAPTER 11: INSTALL THE INSWING ARM ..... 21**  
SECTION 11.1: Secure Guide Track .....21  
SECTION 11.2: Secure the Inswing Arm to Door.....22

**CHAPTER 12: INSTALL THE ARM STOP (SIDE LOAD UNITS)..... 23**

**SERVICE PARTS: C.U. OPUS BOTTOM LOAD HEADER ..... 24**

**SERVICE PARTS: C.U. OPUS SIDE LOAD HEADER ..... 27**

**SERVICE PARTS: SWING ARM ASSEMBLIES ..... 30**

## CHAPTER 1: WARNING LABELS

Warning labels are universal and used to alert an individual of potential harm to one's self or to others. The following warning labels are listed in a hierarchy order that defines the most potential danger first, and the least potential danger last. Please refer to this page in the event that a warning label is displayed within this manual and further definition needs to be explained.

**DANGER**

Indicates potentially dangerous situations. Danger is used when there is a hazardous situation where there is a *high* probability of severe injury or death. It should not be considered for property damage unless personal injury risk is present.

**WARNING**

Indicates a hazardous situation which has *some* probability of severe injury. It should not be considered for property damage unless personal injury risk is present.

**CAUTION**

Indicates a hazardous situation which *may result in a minor injury*. Caution should not be used when there is a possibility of serious injury. Caution should not be considered for property damage accidents unless a personal injury risk is present.

**Attention:** A situation where material could be damaged or the function impaired.

**Notice:** Indicates a statement of company policy as the message relates to the personal safety or protection of property. Notice should not be used when there is a hazardous situation or personal risk.

*Note:* Indicates important information that provides further instruction.

## CHAPTER 2: GENERAL SAFETY RECOMMENDATIONS

**WARNING**

Do not install, operate or service this product unless you have read and understand the General Safety Recommendations, Warning Labels, contained in this manual. Failure to do so may result in bodily injury, or property damage.

**WARNING**

Read, study and understand the installation and operating instructions contained in, or referenced in this manual before operating. If you do not understand the instruction, ask a qualified technician. Failure to do so may result in bodily injury, or property damage and will nullify all warranties.

**DANGER**

Disconnect all power to the junction box prior to making any electrical connections. Failure to do so may result in serious personal or fatal injury. When uncertain whether power supply is disconnected, always verify using a voltmeter.

**DANGER**

Do not place finger or uninsulated tools inside the electrical controller. Touching wires or other parts inside the enclosure may cause electrical shock, serious injury or death.

**CAUTION**

The Ground wire from the Magnum IV Control 120 VAC Harness, and the Incoming 120 VAC Ground wire must be connected to the Ground screw located within the Swing door Header.

**CAUTION**

If the door appears broken or does not seem to work correctly, it should be immediately removed from service until repairs can be carried out or a qualified service technician is contacted for corrective action.

**Notice:** This manual, the owner's manual and all other associated manuals must be given to and retained by the purchasing facility or end user.

**Notice:** Wiring must meet all local, state, federal or other governing agency codes.

**Notice:** All electrical troubleshooting or service must be performed by qualified electrical technicians and must comply with all applicable governing agency codes.

## CHAPTER 3: SCOPE

### SECTION 3.1: To the Installer

The purpose of this manual is to familiarize the installer and purchaser with the proper installation and operation of this system. It is essential that this equipment be properly installed and operational before the door is used by the public. It is the installer's responsibility to inspect the operation of the entrance system to be sure it complies with any applicable standards. In the United States, ANSI Standard 156.10 (Used to cover Full Energy doors) and ANSI Standard 156.19 (Used to cover Low Energy doors) and ANSI Standard Z97.1 covers Glass Installation. Other local standards or codes may apply. Use them in addition to the ANSI standard.

The owner should determine the door is operating properly and should immediately call for service if there is any malfunction. All installation changes and adjustments must be made by qualified, NABCO trained technicians.

If after troubleshooting a problem, a satisfactory solution cannot be achieved, please call Nabco Entrances at 1-877-622-2694 between 8 am – 4:30 pm Central time for additional assistance.

### SECTION 3.2: Objective

Swing Door Conversion Units are designed to be installed onto the top surface of the Door Frame. The Operator is controlled by the Opus Control (Standard) or by the Analog Control (Optional). Both Controls offer many features to accommodate most installation options. This manual offers step by step instructions.

#### CAUTION

**A pedestrian Door that does not have its glass sections installed at the Factory shall specify that the glazing material employed is to comply with the requirement in UL 325 par.30.5.1:**

**“The glazing material in both fixed and sliding panels of all sliding doors and in all unframed swinging doors shall comply with the requirements in the Performance Specifications and Methods of Test for Safety Glazing Material Used in Buildings, ANSI Z97.1. Glazing material for other pedestrian doors shall also comply with ANSI Z97.1, except that single strength or heavier glass may be used for those portions of doors involving a glazed area of less than 1ft<sup>2</sup> (0.9 m<sup>2</sup>) and having no dimension greater than 18 in (457 mm)”.**

## CHAPTER 4: GETTING STARTED

### SECTION 4.1: Mechanical Configurations

Base Model	Conversion Unit Bottom Load	Conversion Unit Side Load
Full Power	GT 400	GT 8400
	GT 600	N/A
Low Energy	GT 500	GT 8500

### SECTION 4.2: Electrical Standards

*Note: It is recommended for the Installer to use an Electrical Conduit to house all incoming 120 VAC wires.*

*Note: All wiring must conform to standard wiring practices and be in accordance with national and local electrical codes.*

Electricity	Description	Current Consumption
Power Input	110VAC - 130 VAC, AC 50-60 Hz	3A (NABCO recommends min. 5A service)
Available Current for accessories	12 VDC	750mA
Available wire size for incoming power	14 AWG	-
<p><i>TOTAL</i> current draw from the Opus Control must not exceed 0.7A when providing power to:</p> <ul style="list-style-type: none"> <li>▶ Sensors, Modules, Accessories. Auxiliary Equipment</li> </ul> <p>If <i>TOTAL</i> current draw exceeds 0.7A the installer must utilize an auxiliary power supply such as the NABCO Transformer 24 VAC, P/N A-01185.</p>		

**SECTION 4.3: Installation Specifications**

Specification	Measurement	
Minimum Frame Face for Mounting	1-3/4 inches (44mm)	
Minimum Door Thickness	1-3/4 inches (44 mm)	
Minimum Clearance from Top of Door to Ceiling	Bottom Load	Side Load
	6-1/8" (156 mm)	7-18" (181 mm)
Door Width	Specified when ordered	

**SECTION 4.4: Base Unit Types**

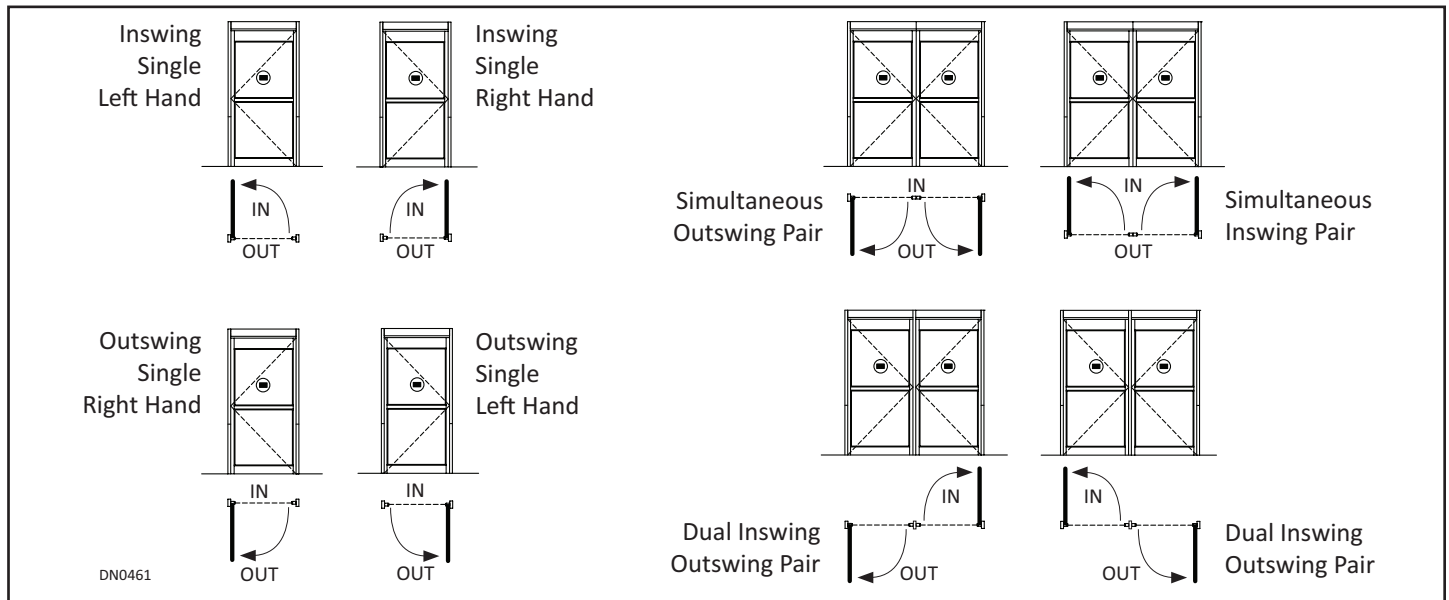
**4.4.1: Full Energy Doors**

Utilize Sensor(s) to open a Swing door: Sensors activate the Control by detecting motion of pedestrians (or moving objects) coming into range.

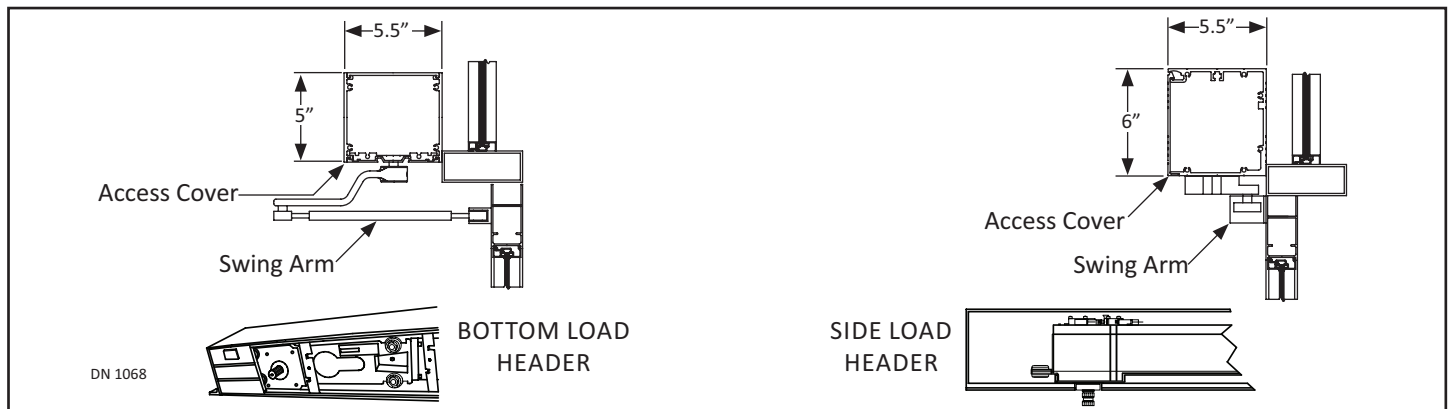
**4.4.2: Low Energy Doors**

Utilize a Knowing Act to open a Door: A conscious effort that is carried out in many different ways, including (but not limited to): manually opening a Door; pressing various types of Push Plates; turning a Key switch; utilizing a keypad or card reader, etc.

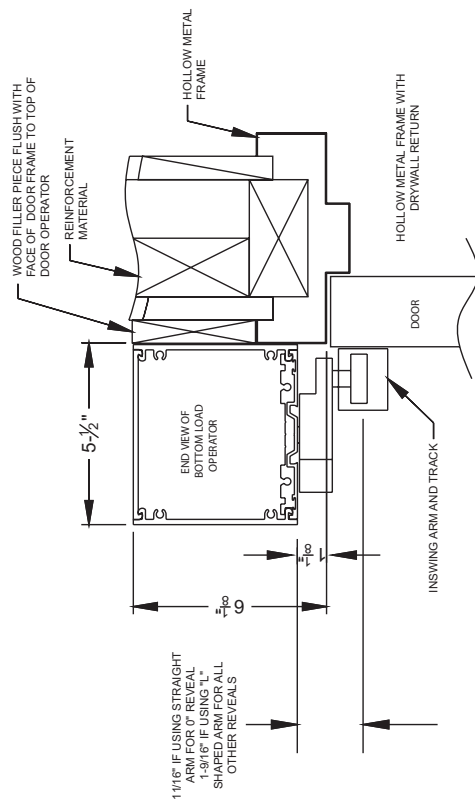
**SECTION 4.5: Swing Door Types**



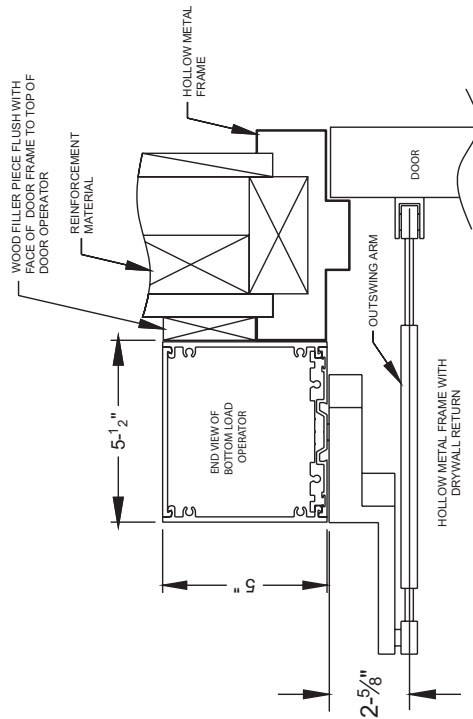
**SECTION 4.6: Header Types**



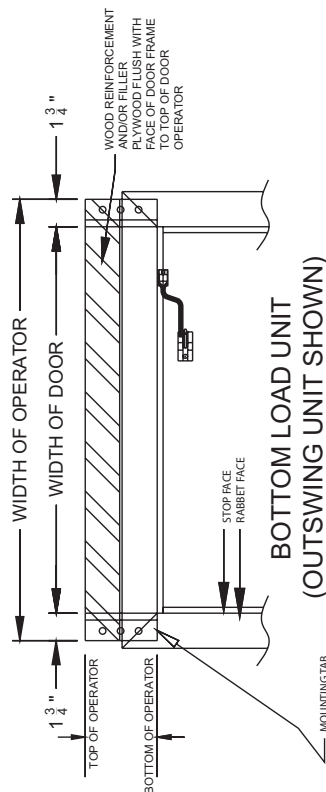
# CHAPTER 5: INSTALL THE BOTTOM LOAD HEADER



**BOTTOM LOAD INSWING UNIT**



**BOTTOM LOAD OUTSWING UNIT**



**BOTTOM LOAD UNIT (OUTSWING UNIT SHOWN)**

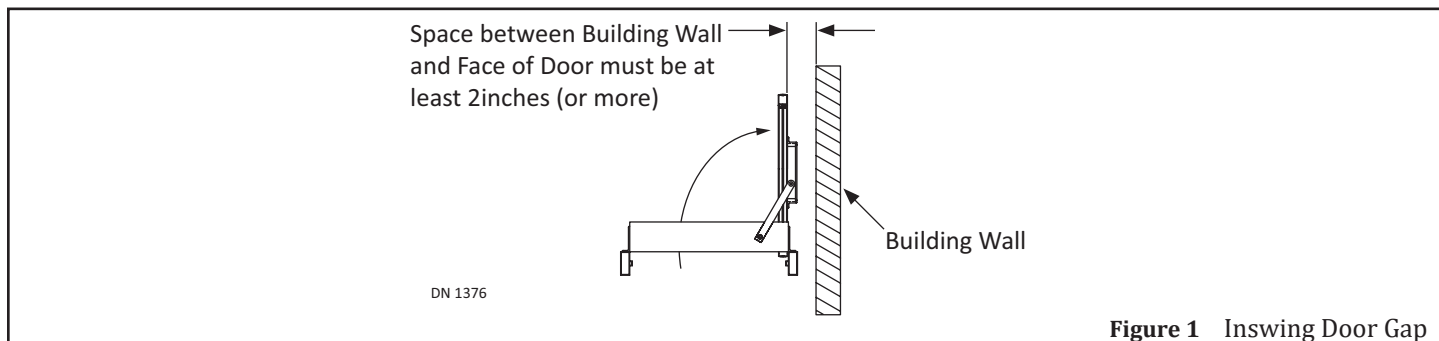
**NOTES:**

1. DOOR OPERATOR INTENDED TO MOUNT FLUSH WITH FACE OF DOOR FRAME.
2. FINISHED WALL ABOVE MUST BE FLUSH WITH FACE OF FINISHED FRAME UP TO HEIGHT OF 8" ABOVE BOTTOM EDGE OF FRAME FACE.
3. REINFORCEMENT MATERIAL (EITHER PLYWOOD OR SOLID STRUCTURAL LUMBER) MUST BE INSTALLED BEHIND AND/OR IN PLACE OF FINISHED WALL MATERIAL AND BE SECURED TO WALL FRAMING TO PROVIDE STRONG SURFACE FOR MOUNTING DOOR OPERATOR. IF FACE OF FRAME IS NOT FLUSH WITH FINISHED WALL, ADDITIONAL PLYWOOD IS REQUIRED AS SHOWN TO PROVIDE FLUSH AND STABLE SURFACE FOR MOUNTING DOOR OPERATOR.
4. REFER TO INSTALLATION INSTRUCTION MANUALS FOR EACH OPERATOR FOR ADDITIONAL MOUNTING DETAILS AND DIMENSIONS.
5. DRAWING IS FOR GENERAL REFERENCE PURPOSES ONLY AND NOT TO SCALE.

DN 1377

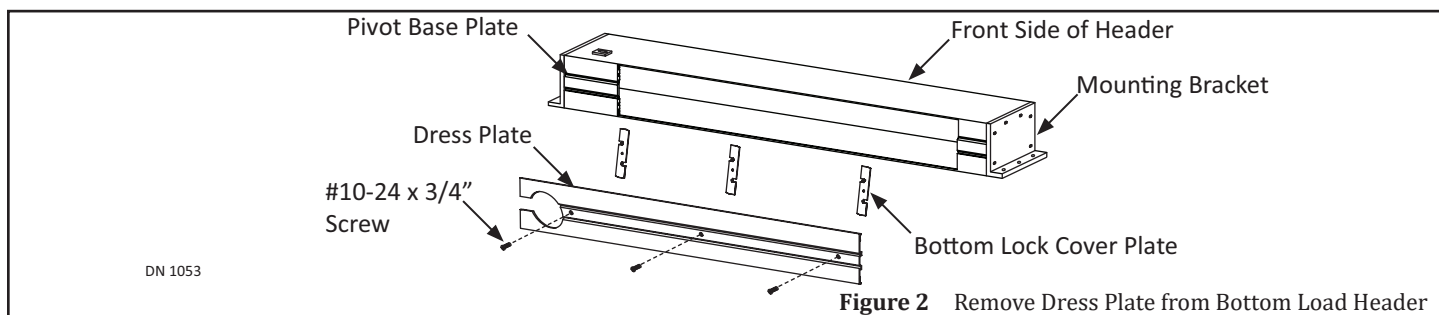
### SECTION 5.1: Measure Distance Between Door and Building Wall

1. Open the Inswing door 90 degrees (Outswing doors do not need to be measured).
2. Measure between the wall and the outside face of the Swing Door. There must be a 2 inch minimum gap.
  - a. If there is less than a 2 inch gap, please call Customer Service at (877) 622-2694.



### SECTION 5.2: Prepare the Header

1. Place Header on flat surface with Bottom facing up. Protect Header from scratches. Remove #10-24 x 3/4 inch screws and Dress Plate, plus boxes and/or parts bags from inside the Header. Set aside.
2. Mark the locations of each Lock Cover Plate to ensure it is reinstalled in the correct position. Remove Lock Cover Plates.

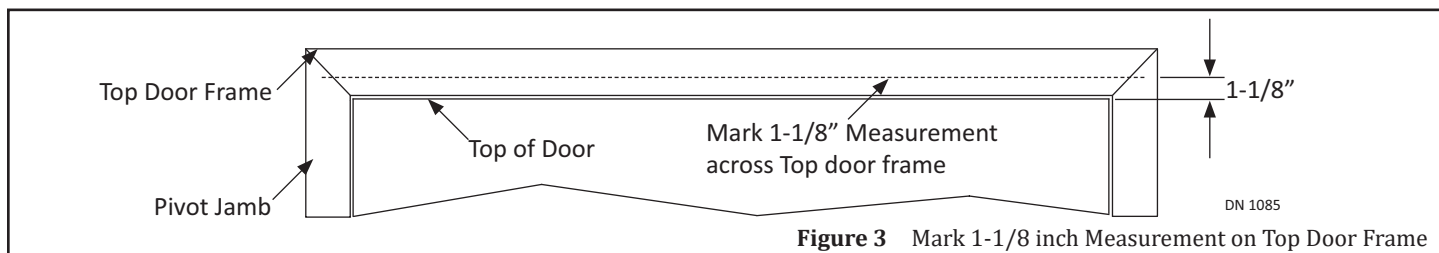


### SECTION 5.3: Install the Bottom Load Header onto Door Frame

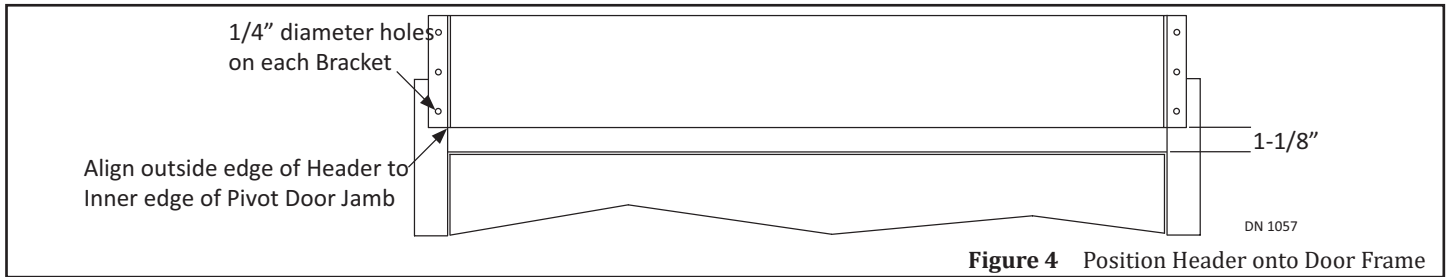
*Note: The following instructions are for typical Metal Doors and Frame Profile. If the Door Frame is not Metal, ensure the Door Frame being used is of equal strength. It is recommended to use lag bolts.*

*Note: If the Door Frame is not properly reinforced nor anchored to the building surface, and/or is hollow, reinforce the Door Frame with 1/4-20 blind rivnuts (not provided by NABCO).*

1. Go to the Pivot Side of Swing door. Measure up 1-1/8 inch from the Top of Door to the face of Door Frame.
2. Mark a Horizontal Line on the face of the Top door frame, at both ends.

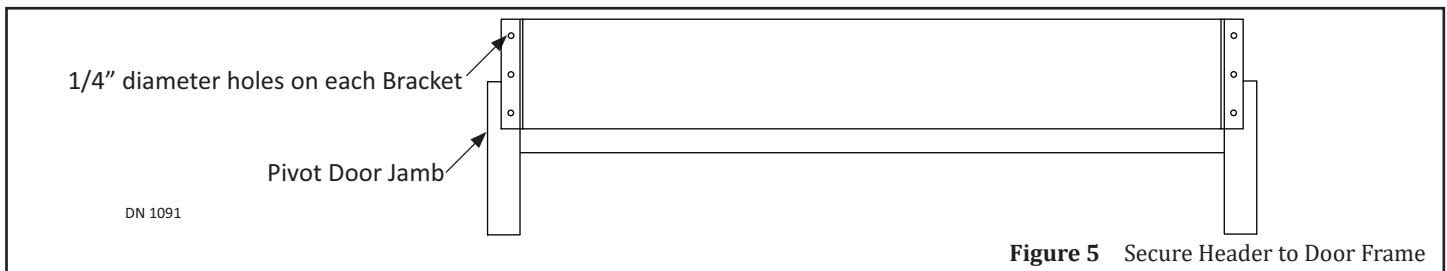


3. Lift the Header up against the Top door frame until the bottom edge of Header is butted up against the Horizontal Lines.
4. To ensure proper operation of the Swing Arm:
  - ▶ For a Door Jamb that is 1-3/4 inches wide, position the Pivot side of Header so it is flush to the outside edge of the Pivot Door Jamb.
  - ▶ For a Door Jamb that is wider than 1-3/4 inches, measure from the inner edge of the Pivot Door Jamb to the center. Mark a vertical line at the 1-3/4 inch measurement. The Pivot side of Header must butt against the 1-3/4 inch mark.



**Figure 4** Position Header onto Door Frame

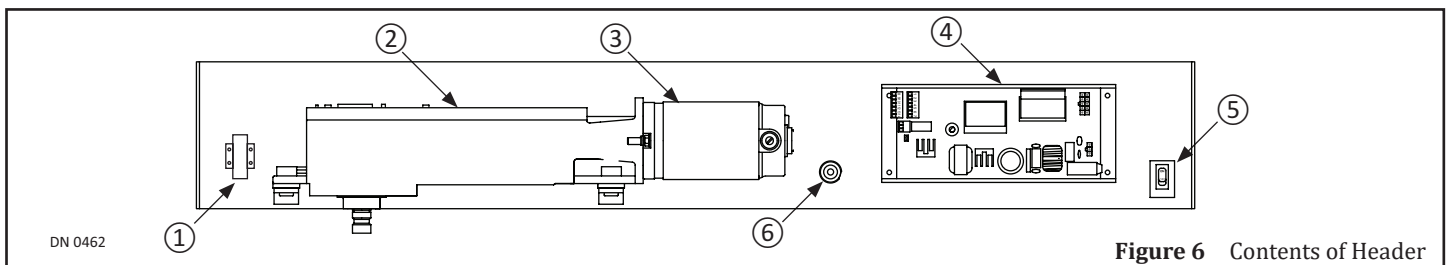
5. Ensure the Header is square and level. Use the Header as a template to mark screw holes onto the face of the door frame.
6. Insert Power Wiring through the 7/8 inch hole located on the side of Header. It is recommended to use a Conduit.
  - a. It is recommended to insert all other Wiring through a separate hole.
7. Butt the bottom edge of Header against the 1-1/8 inch Horizontal Line.
8. Line up the scwew holes. Secure the Header to the Door Frame. It is recommended to use Lag Bolts.
  - a. For additional mounting, secure the Header to the Studs located behind the Shim.



**Figure 5** Secure Header to Door Frame

**SECTION 5.4: Install Bottom Load Components**

*Note: Location of Contents within Header are subject to change according to Swing door specifications.*

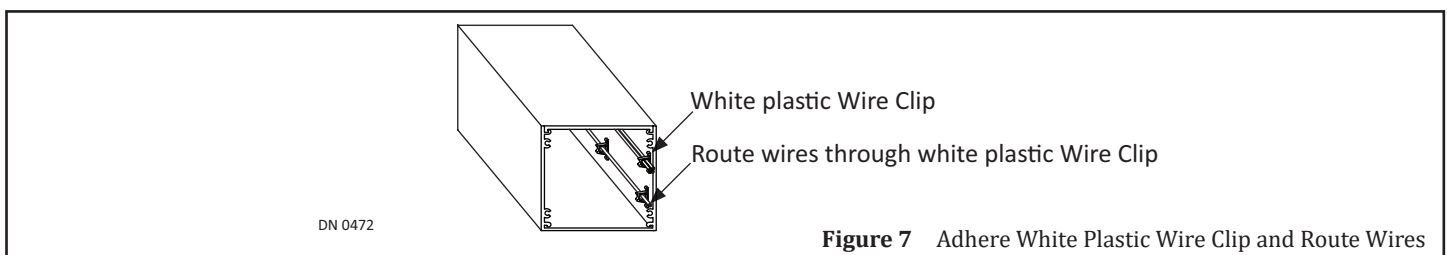


**Figure 6** Contents of Header

- |                           |                  |
|---------------------------|------------------|
| 1. Transformer (Optional) | 4. Ground Screw  |
| 2. Operator               | 5. Rocker Switch |
| 3. Motor                  | 6. Control       |

**5.4.1: Secure Incoming Wires**

1. Obtain (self sticking) white plastic Wire Clips provided by NABCO.
2. Adhere each Wire Clip to sides of Header. Insert wiring (as deemed necessary).
  - a. 120 VAC Power wires must be routed separate from other wiring, adhere those Wire Clips inside the Header, near the top to prevent pinching.

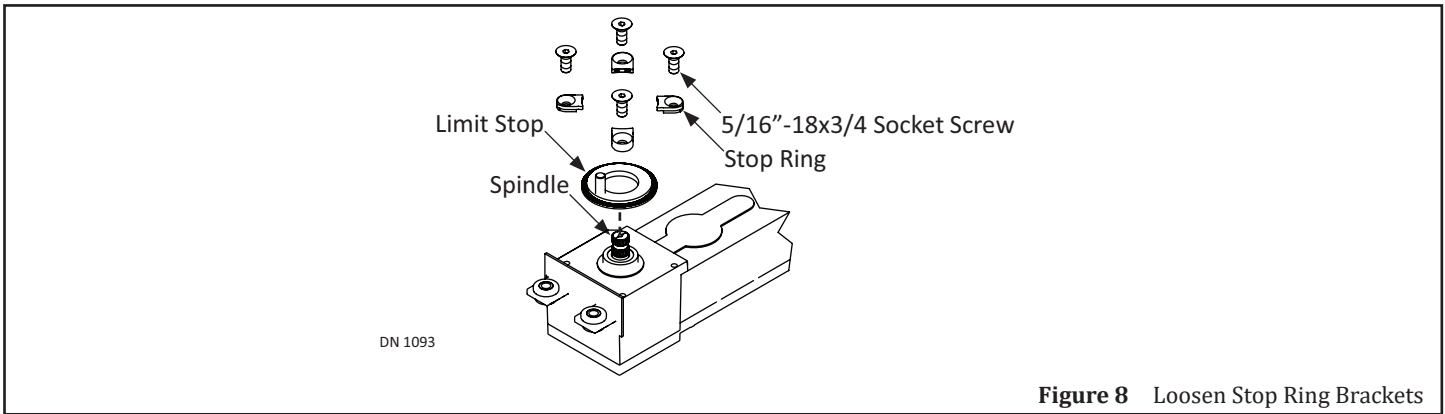


**Figure 7** Adhere White Plastic Wire Clip and Route Wires



### 5.4.2: Install the Stop Ring

1. Place the Motor/Operator on a flat surface with the underside facing up.
2. Obtain the Stop Ring Assembly provided by NABCO. Slide the Limit Stop onto the Spindle.
3. Secure (4) Ring Stops onto the Limit Stop with 5/16-18 Socket Head screws. Do not fully tighten at this time.
4. Once the Swing Arm is fully installed and Pre-Load has been tested:
  1. Open the Swing door 90 degrees.
  2. Rotate the Limit Stop Spindle until it hits the Swing Arm.
  3. Tighten down (4) Ring Stops with 5/16-18 Socket Head screws.



**Figure 8** Loosen Stop Ring Brackets

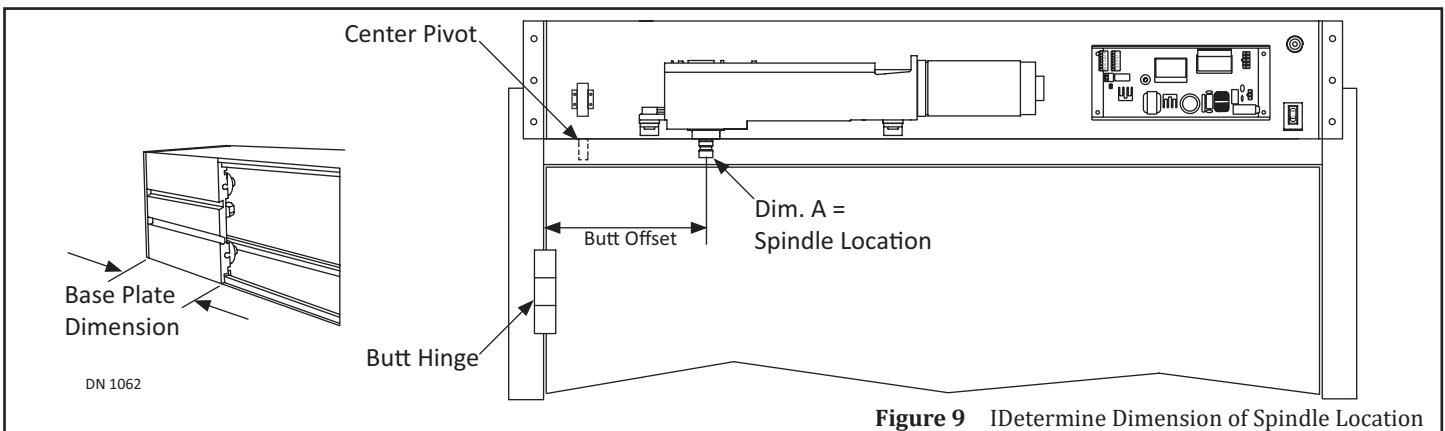
### 5.4.3: Install the Bottom Load Motor/Operator

1. Go to Table 1 to determine the distance from the center of the Operator Spindle to the Center Pivot or the inside edge of the Pivot Door Jamb.

**Table 1** Dimension "A" Spindle Location

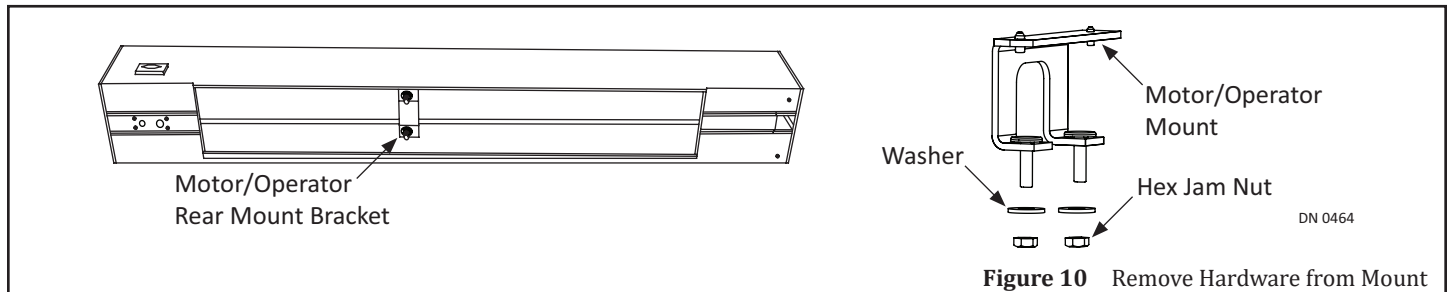
Bottom Load Units		Inswing				Outswing			
		With Fingerguard		No Fingerguard		With Fingerguard		No Fingerguard	
Model	Pivot Type	Spindle Loc.	Base Plate	Spindle Loc.	Base Plate	Spindle Loc.	Base Plate	Spindle Loc.	Base Plate
GT 400	Butt/Offset	N/A	N/A	5"	2-1/2"	N/A	N/A	7-1/4"	4-3/4"
	Center Pivot	6"	3-1/2"	5"	2-1/2"	8-1/4"	5-3/4"	7-1/4"	4-3/4"
GT 500	Butt/Offset	N/A	N/A	5"	2-1/2"	N/A	N/A	5"	2-1/2"
	Center Pivot	6"	3-1/2"	5"	2-1/2"	6"	3-1/2"	5"	2-1/2"
GT 600	Butt/Offset	N/A	N/A	5"	2-1/2"	N/A	N/A	7-1/4"	4-3/4"
	Center Pivot	6"	3-1/2"	5"	2-1/2"	8-1/4"	5-3/4"	7-1/4"	4-3/4"

2. Mark that measurement onto the face of Swing Door.

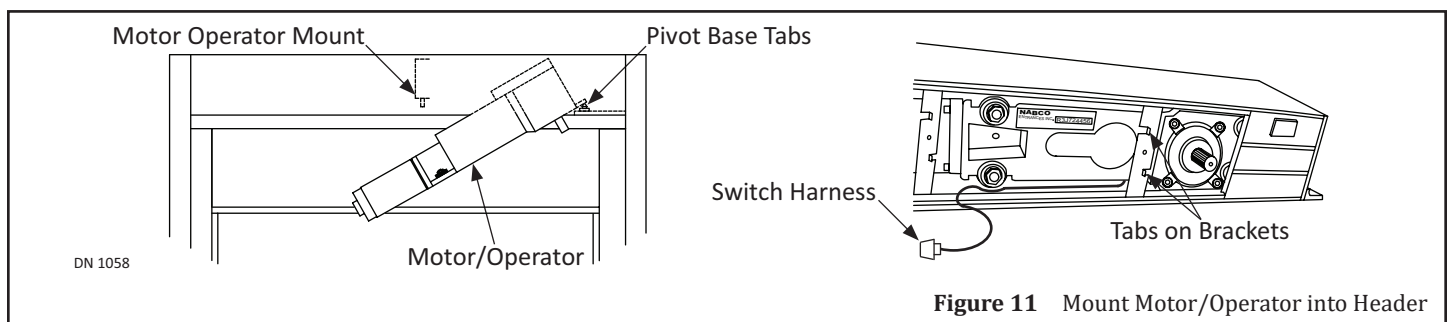


**Figure 9** Determine Dimension of Spindle Location

3. Locate the factory installed Rear Mount Bracket at the top of Header.
4. With a 9/16 inch Deep Well Socket and Ratchet, remove (2) 3/8-16 inch Hex Jam Nuts and (2) 7/16 x 1 inch Washers from (2) Studs extending downward. Set aside.
5. Hold the Front end of Motor/Operator at an upward angle to slide Front Mount onto (2) Pivot Base Tabs located inside the Header.



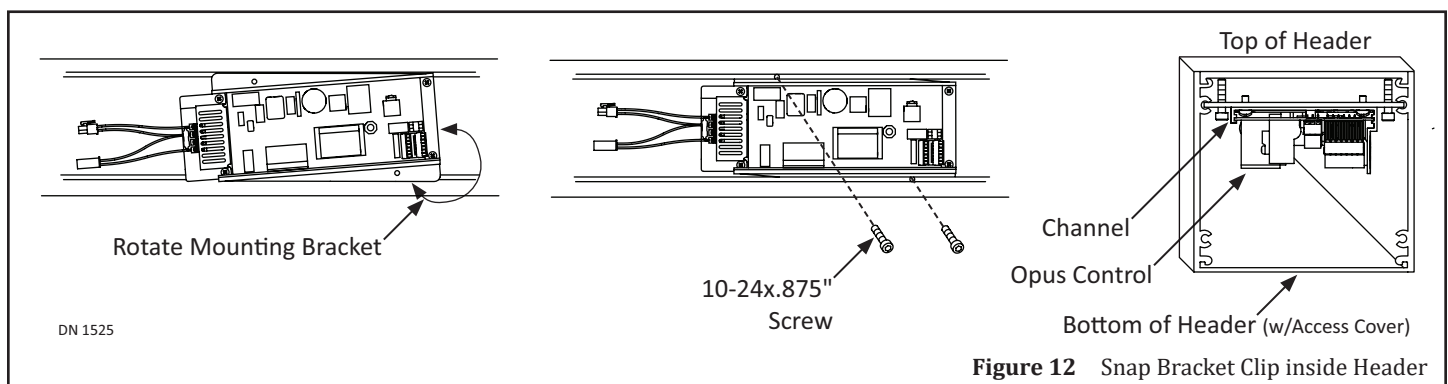
6. Lift the rear of the Motor Operator up onto (2) studs extending downward.
  - a. Ensure the Switch Harness is tucked between the back wall of Header and above the Mounting Bracket.
7. Secure the Motor/Operator with (2) 3/8-16 inch Hex Jam Nuts and (2) 7/16 x 1 inch Washers.
  - a. It is important not to pinch any wiring during the Motor/Operator installation.



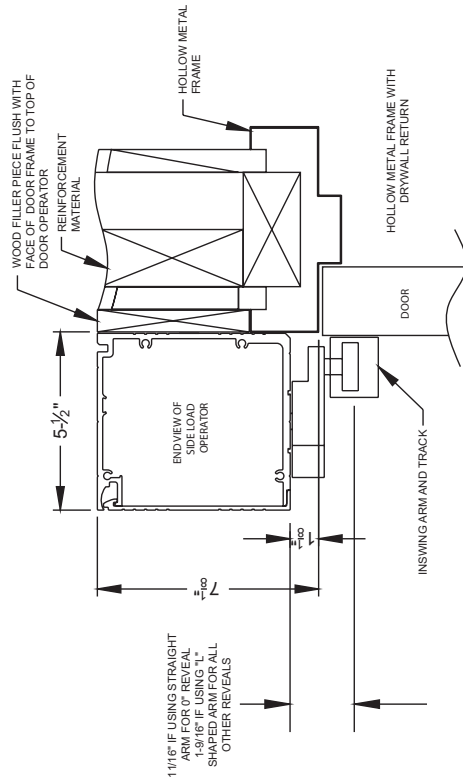
#### 5.4.4: Install the Control

*Note: It may be necessary to mount a Soft Starter Capacitor on the Operator prior to installing the Analog Control. For detailed information, please refer to the "Analog Control Wiring and Adjustment Manual; P/N 15-10745".*

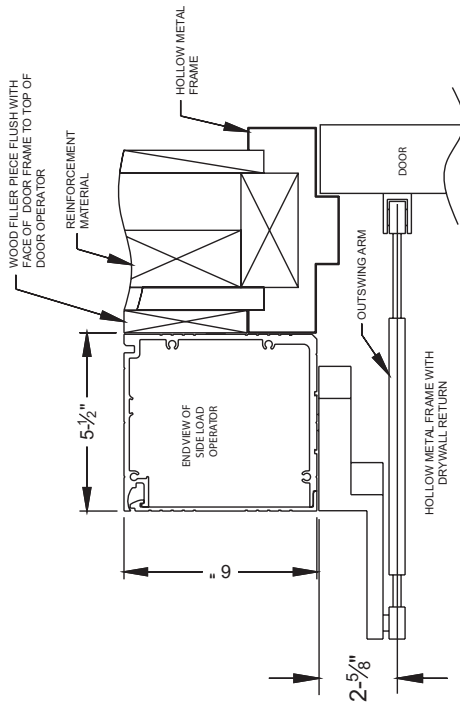
1. Obtain the Opus Control assembly.
2. Locate where the Opus Control needs to be installed within the Header.
3. Insert the Opus Control with the Mounting Bracket at a 90 degree angle (Control will approximately be at a 4 degree angle).
4. Rotate the Opus Control until each side of the Mounting Bracket slides into each Channel located at the top; inside Header.
5. Secure the Mounting Bracket to the Header by tightening (2) 10-24x.875 inch Socket Head Cap screws, until the tip butts against the inside wall of the Header.



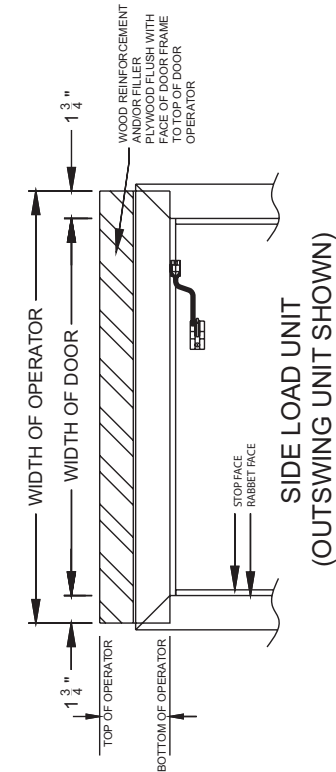
# CHAPTER 6: INSTALL THE SIDE LOAD HEADER



**SIDE LOAD INSWING UNIT**



**SIDE LOAD OUTSWING UNIT**



**NOTES:**

1. DOOR OPERATOR INTENDED TO MOUNT FLUSH WITH FACE OF DOOR FRAME.
2. FINISHED WALL ABOVE MUST BE FLUSH WITH FACE OF FINISHED FRAME UP TO HEIGHT OF 8" ABOVE BOTTOM EDGE OF FRAME FACE.
3. REINFORCEMENT MATERIAL (EITHER PLYWOOD OR SOLID STRUCTURAL LUMBER) MUST BE INSTALLED BEHIND AND/OR IN PLACE OF FINISHED WALL MATERIAL AND BE SECURED TO WALL FRAMING TO PROVIDE STRONG SURFACE FOR MOUNTING DOOR OPERATOR. IF FACE OF FRAME IS NOT FLUSH WITH FINISHED WALL, ADDITIONAL PLYWOOD IS REQUIRED AS SHOWN TO PROVIDE FLUSH AND STABLE SURFACE FOR MOUNTING DOOR OPERATOR.
4. REFER TO INSTALLATION INSTRUCTION MANUALS FOR EACH OPERATOR FOR ADDITIONAL MOUNTING DETAILS AND DIMENSIONS.
5. DRAWING IS FOR GENERAL REFERENCE PURPOSES ONLY AND NOT TO SCALE.

DN 1378

## SECTION 6.1: Before Installing the Header

1. Open the Inswing door 90 degrees. Outswing doors do not need to be measured.
2. Measure between the wall and the outside face of the Swing Door.
  - a. There must be a 2 inch minimum gap. If there is less than a 2 inch gap, please call Customer Service at (877) 622-2694.

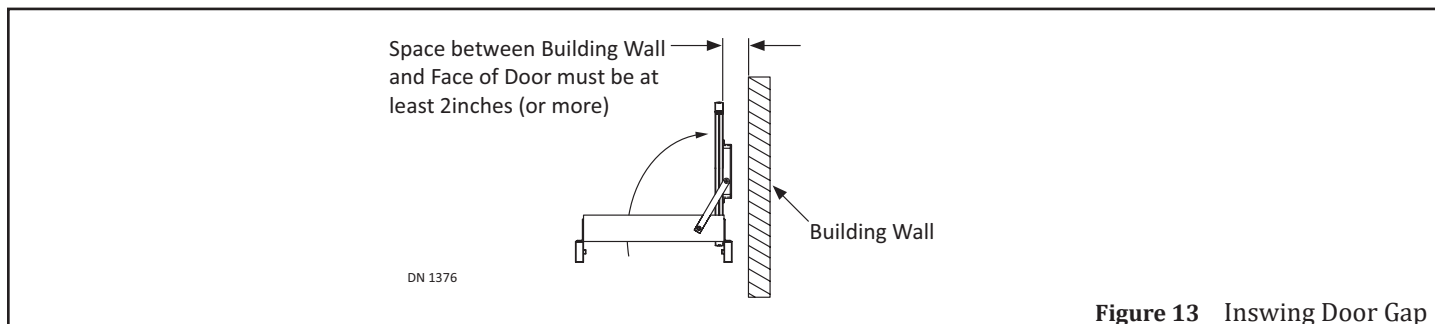


Figure 13 Inswing Door Gap

## SECTION 6.2: Secure the Side Load Header to Door Frame

*Note: The following instructions are for typical Metal Doors and Frame Profile. If the Door Frame is not Metal, ensure the Door Frame being used is of equal strength. It is recommended to use lag bolts.*

1. Go to the Strike side of Header. Drill one 7/8 inch hole through the Header to allow all wiring to be drawn inside.
  - a. The Side Load Header can be ordered with a Knockout hole located at either end of the Header. For details, please call Customer Service at 1-888-679-3319.
2. Go to the back wall inside Header on the Pivot side.
3. Measure 1 inch from the End Cap towards the center of Header. Mark a Horizontal Line.
4. Measure at least 1/2 inch from the bottom of Header towards the top. Mark a Vertical Line across the Horizontal line. This is the center of the first screw hole. Drill 1/4 inch screw hole.
5. Measure at least 1/2 inch from the top of Header towards the bottom. Mark (1) more Horizontal line across the Vertical line directly above the first screw hole. This is the center of the second screw hole. Drill 1/4 inch screw hole.
6. Go to the other End Cap. Repeat steps 3 thru 5.

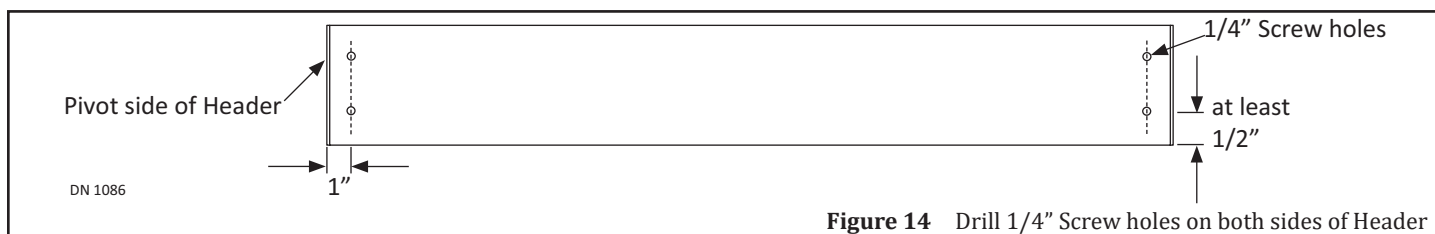


Figure 14 Drill 1/4" Screw holes on both sides of Header

*Note: If the Door Frame is not properly reinforced nor anchored to the building surface, and/or is hollow, reinforce the Door Frame with 1/4-20 blind rivnuts (not provided by NABCO).*

7. Go to the Pivot Side of Swing door. Measure up 1-1/8 inch from the Top of door to the face of Door Frame.
8. Mark a Horizontal Line onto the face of the Top door frame, at both ends.

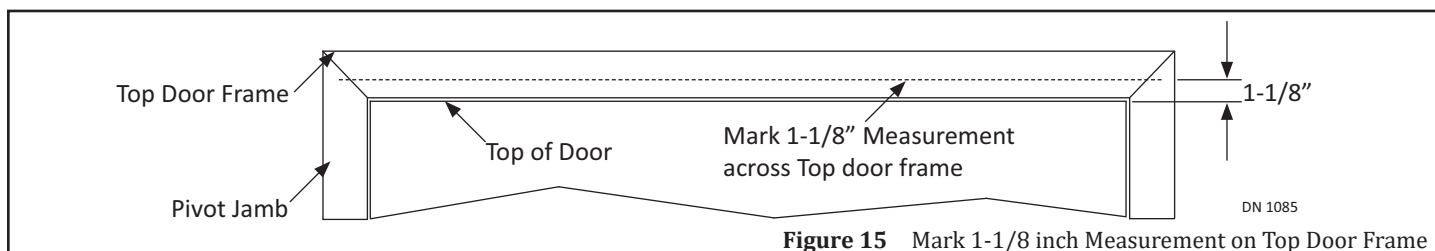
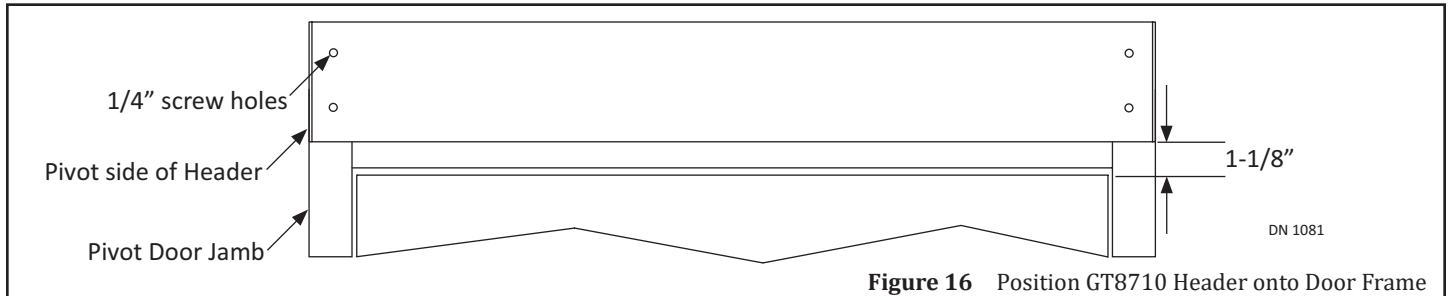


Figure 15 Mark 1-1/8 inch Measurement on Top Door Frame

9. Lift the Header up to butt the bottom edge of Header against the Horizontal Line, at both ends.

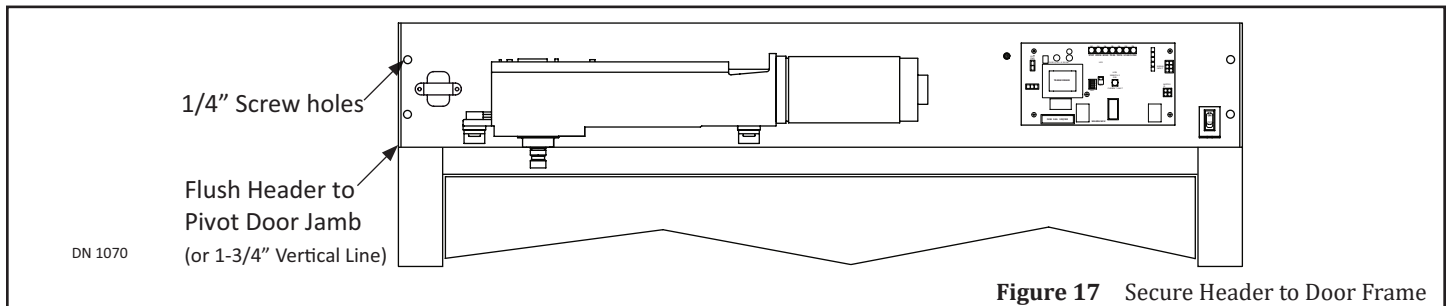
10. To ensure proper operation of the Swing Arm:
  - ▶ For a Door Jamb that is 1-3/4 inches wide, flush the Pivot side of Header o the outside edge of the Pivot Door Jamb.
  - ▶ For a Door Jamb that is wider than 1-3/4 inches, measure from the inner edge of the Pivot Door Jamb to the center. Mark a vertical line at the 1-3/4 inch measurement. The Pivot side of Header must butt against the 1-3/4 inch mark.
11. Ensure the Header is square and level. Use the Header as a template to mark screw holes onto the face of the door frame.



**Figure 16** Position GT8710 Header onto Door Frame

12. Insert Power Wiring through the 7/8 inch hole located at the left or right side of Header End Cap.
  - a. It is recommended to use a Conduit.
  - b. It is recommended to insert all other Wiring through a separate hole.
13. Line up the screw holes. Secure the Header to the Door Frame. It is recommended to use Lag Bolts.

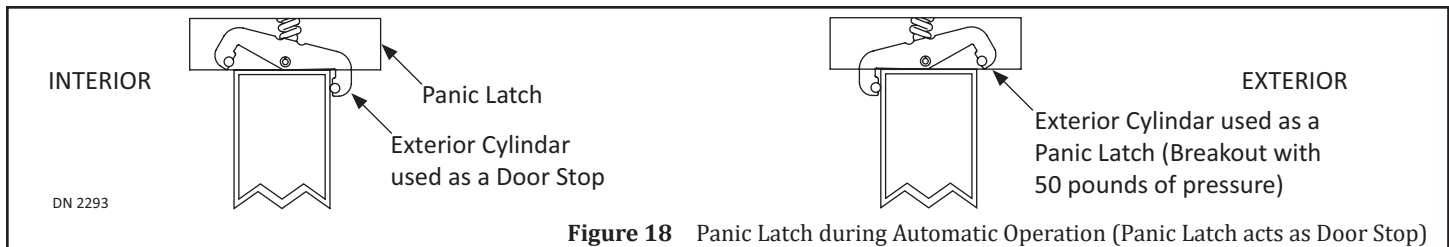
*Note: For additional mounting, secure the Header to the Studs located behind the Shim. It is recommended to use Lag Bolts.*



**Figure 17** Secure Header to Door Frame

## CHAPTER 7: INSTALL THE PANIC LATCH (IN SWING DOORS ONLY)

- ▶ During Automatic Operation: The Inswing door opens to the Interior side of the building/room. The Cylindrical portion of the Panic Latch is then used as a Door Stop.
- ▶ During Emergency Operation: The Inswing door is manually pushed Out to the exterior side of the building/room (not to exceed 50 pounds of pressure; per ANSI code). The Cylindrical portion of the Panic Latch flips to allow emergency egress and immediately shuts the Swing door OFF.



**Figure 18** Panic Latch during Automatic Operation (Panic Latch acts as Door Stop)

### SECTION 7.1: Create the Cut Out under the Top Door Frame

1. Measure the width and height of the Top Door Frame. The Top Door Frame must be at least: (4) inches wide x (1-3/4) inches high. The actual thickness of the Frame must be at least 1/8) inches.
2. It is recommended to measure/mark at least (1/8) inch from the Strike Jamb Tube towards the center of the door opening.

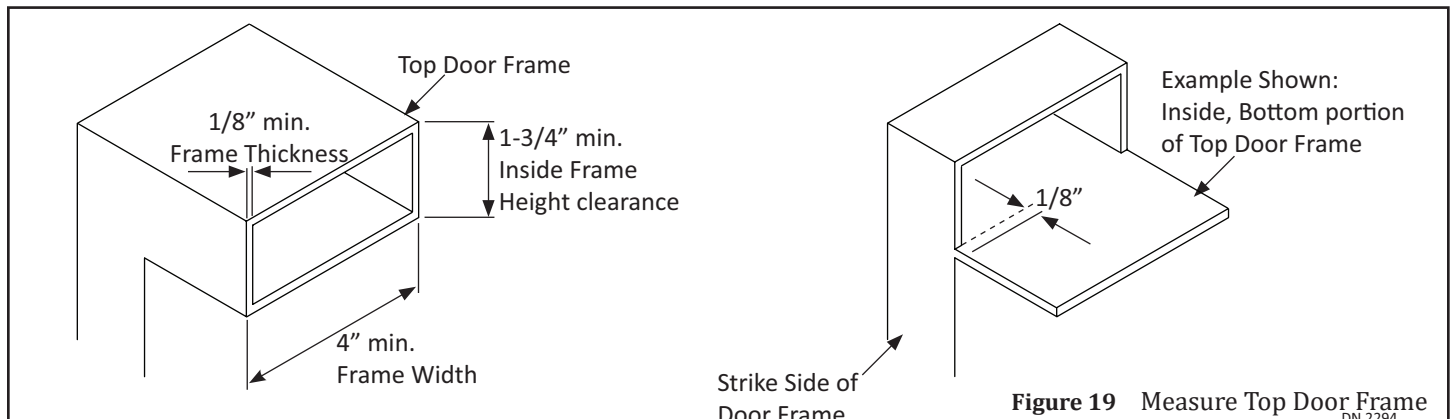


Figure 19 Measure Top Door Frame

3. Go to the Exterior side of the Door Frame. Close the Swing Door.
4. From the Strike Jamb Tube, trace a line along the Swing Door towards the center. Open the Swing Door.
5. Obtain the Panic Latch. Turn the Panic Latch so the (EXT→) (exit arrow) points to the Exterior side of the Building.
6. Flip the Panic Latch upside down. Butt the long side of the Panic Latch against the (1/8) inch mark and then align the exterior cylindrical to the traced line. Please see Figure 19.
7. Hold the Panic Latch in place. Trace around the Panic Latch onto the underside of the Top Door Frame.
8. Measure the traced rectangle to ensure the cut out will be the appropriate size: at least (1-1/4) inch wide x (3-3/4) inch long.

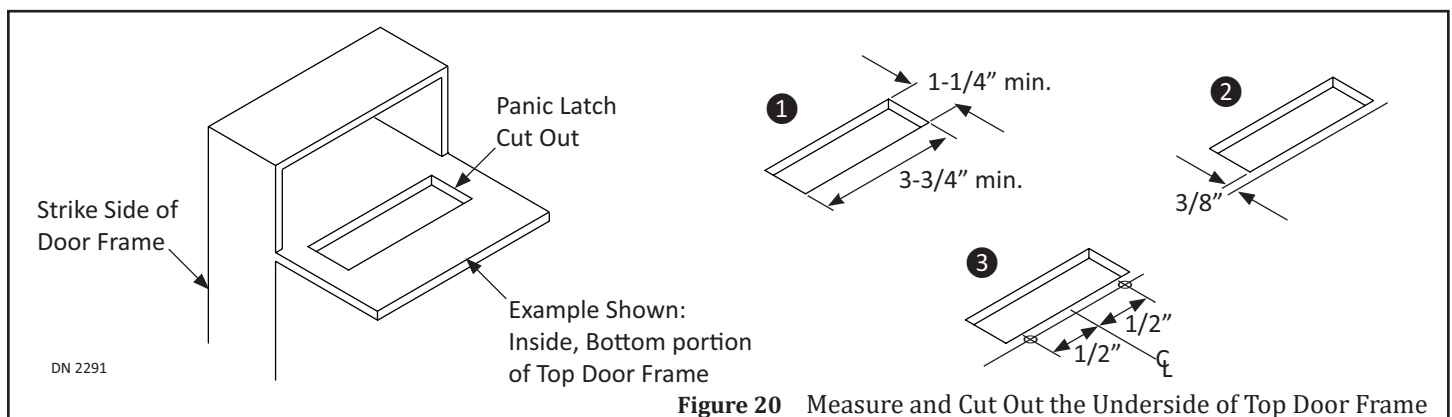


Figure 20 Measure and Cut Out the Underside of Top Door Frame

9. Cut out the measured rectangle. Ensure Cut Out is big enough for the Bracket to fit.
10. Measure (3/8) inch from the Pivot side of the Cut Out towards the center of the Top Door Frame. Mark that spot with a line that is the full length of the Cut Out.
11. Measure and mark the center of the full length of the Cut Out.
12. Measure (1/2) inch from the center line towards the exterior side of the Top Door Frame. Mark that spot so it crosses over the (3/8) inch line.
13. Measure (1/2) inch from the center line towards the interior side of the Top Door Frame. Mark that spot so it crosses over the (3/8) inch line.

## SECTION 7.2: Install the Panic Latch

1. Obtain the Mounting Bracket assembly. Align the (2) screw holes located on the narrow lip of the Mounting Bracket to the center of each marked spot.
  - a. If the screw holes do not align, center and mark again.
2. Drill one (3/8") diameter screw hole at each marked spot.
3. Insert the Mounting Bracket into the Cut Out. Secure the Mounting Bracket with (4) .219 x .375 x .30" Washers and (2) 10-24 x .5" Screws.
4. Obtain and then turn the Panic Latch so the (EXT→) (exit arrow) points to the Exterior side of the Building. Failure to do so, will install the Panic Latch backwards.

5. Insert the Panic Latch into the opening (with the wires and spring coil at the top) until the Panic Latch butts up against the Mounting Bracket. Align the Screw Holes.
6. Secure the Panic Latch to the Mounting Bracket with (2) 10-24 x 1.25" Screws.
7. Do Not wire or test the Panic Latch at this time.
  - a. For wiring instructions please refer to P/N C-00139 Opus Wiring and Programming Manual.

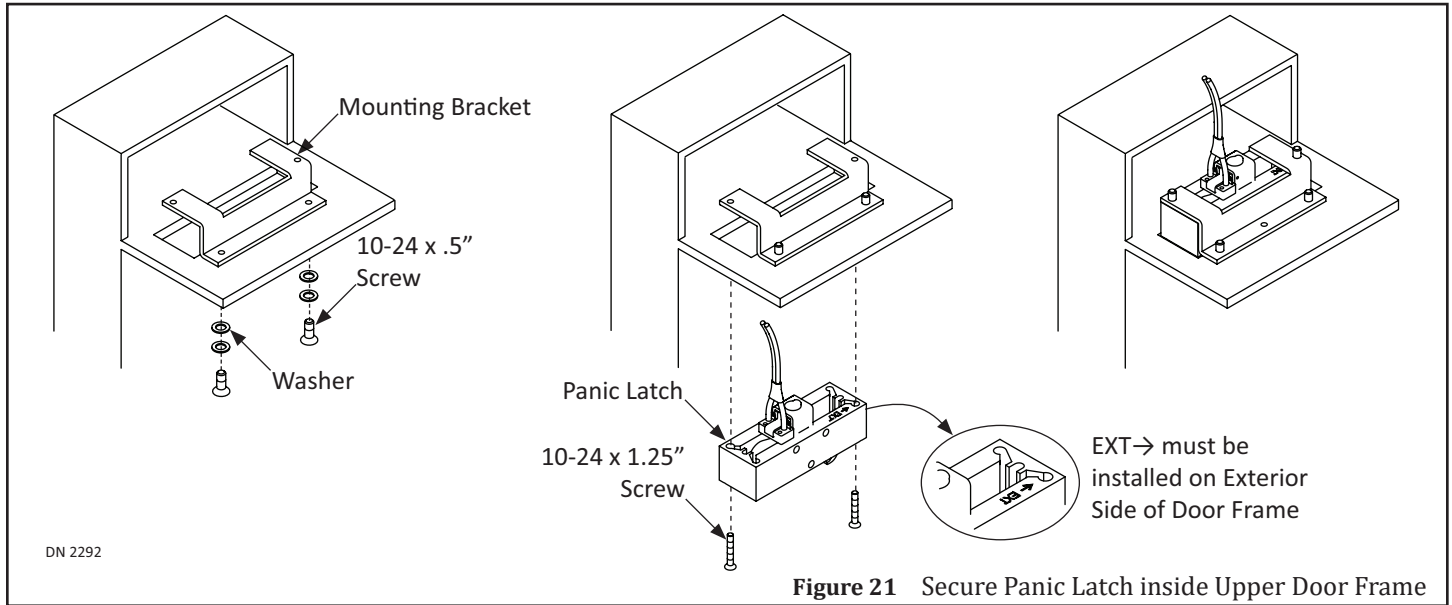
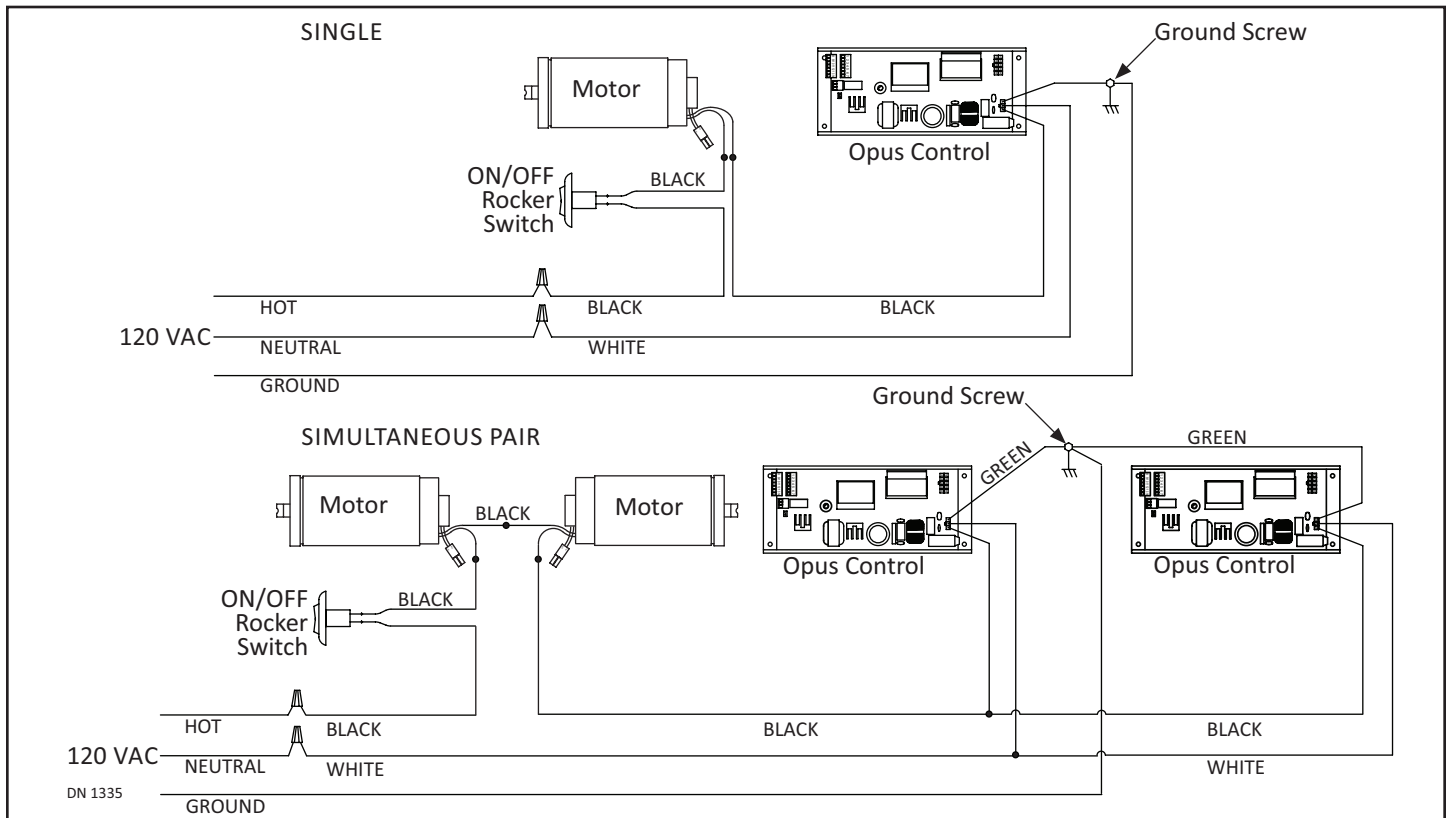


Figure 21 Secure Panic Latch inside Upper Door Frame

### CHAPTER 8: 120 VAC GENERAL WIRING



**WARNING**

Shut the installation site, branch Circuit Breaker OFF. Failure to do so may result in serious personal or fatal injury. When uncertain whether power supply is disconnected, always verify using a voltmeter.

**WARNING** All high voltage electrical connections must be made by licensed electricians according to National and Local electrical codes/regulations.

**CAUTION** Permanent wiring shall be employed as required by local codes.

**CAUTION** Keep all Incoming 120 VAC wiring separate from low voltage wiring within Header. 120 VAC Power wires must be routed (separate from other wiring) located near the top of inside Header.

**CAUTION** Ensure that the Grounding of the Electric Power Supply is installed/connected in a proper way (especially the PE Cable from the Building Side).

**Attention:** Insert all Incoming 120 VAC Power wires into the pre drilled Electric Service Access Hole located at the left or right side of Header End Cap.

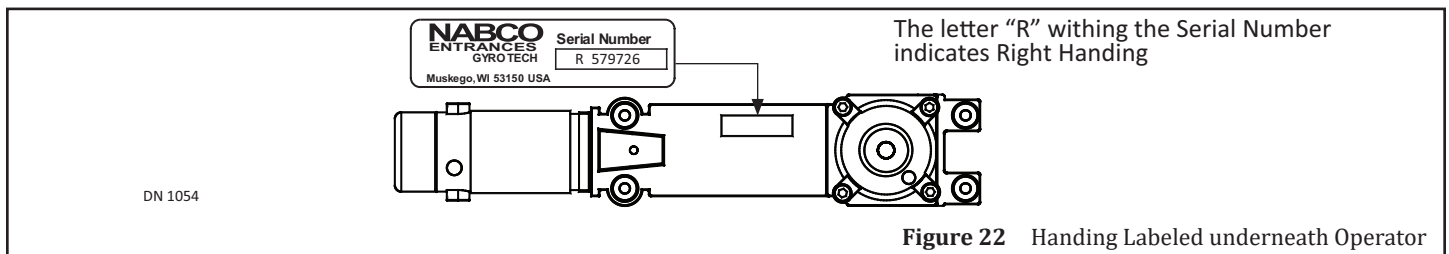
**Attention:** Electrical circuit to Nabco operator must not be not shared with other equipment such as lighting, cash registers, or any device that might cause electrical interference on the circuit.

*Note: It is recommended for the Installer to house all Incoming 120 VAC wires within an Electrical Conduit.*

## CHAPTER 9: HANDING

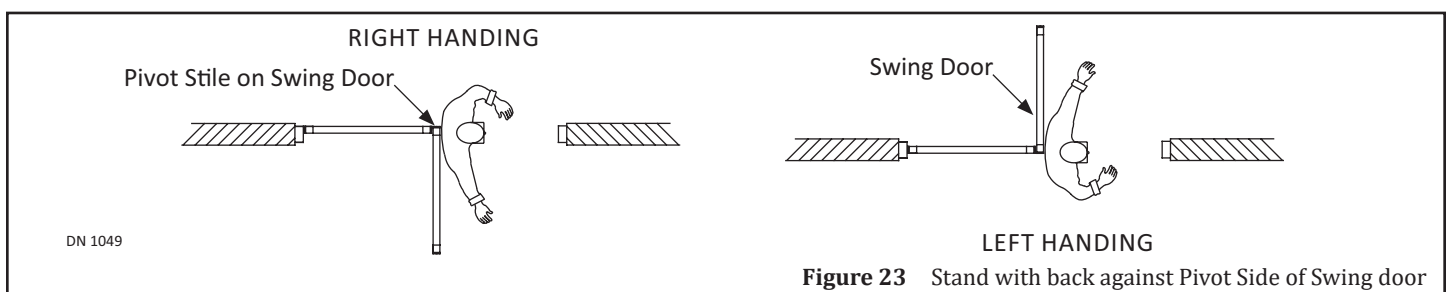
### SECTION 9.1: How to Determine Handing

- ▶ Locate the Serial Number underneath the Operator.
  - The Letter (L) or (R) located in front of the Serial Number indicates the Handing.



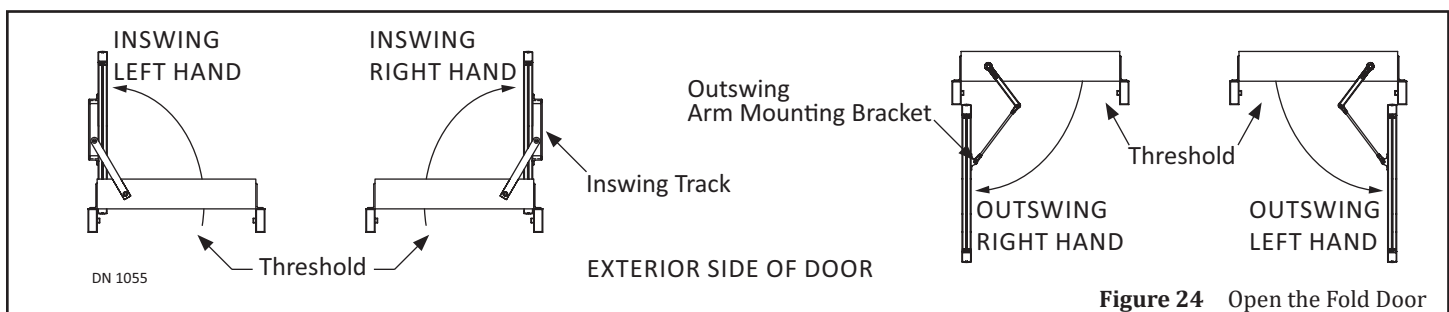
**Figure 22** Handing Labeled underneath Operator

- ▶ Stand underneath the Header and then open the Swing door. Butt your back against the Pivot side of the Swing door. Swing out your (right or left) arm in the direction the Swing door opened. If you swing out your Right Arm the Swing Door is Right Handed. If you swing out your Left arm the Swing Door is Left Handed.



**Figure 23** Stand with back against Pivot Side of Swing door

- ▶ If the Swing Arm does not swing underneath the Header to open, it is an Inswing Unit.
- ▶ If the Swing Arm swings underneath the Threshold to open, it is an Outswing Unit.



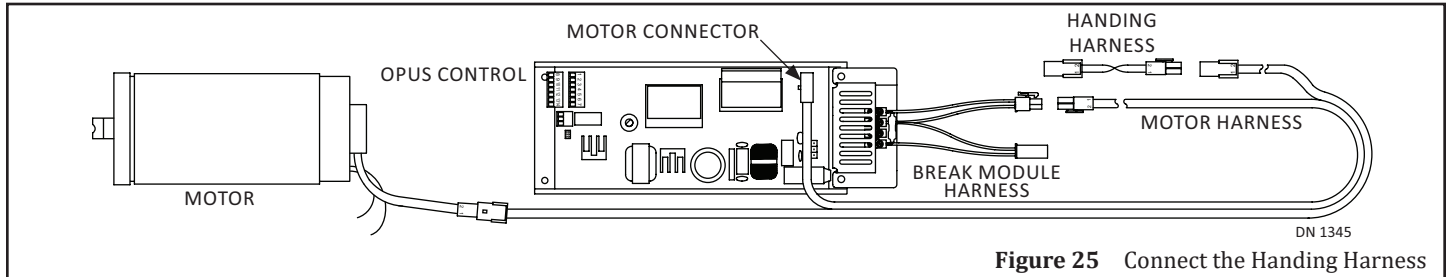
**Figure 24** Open the Fold Door



### SECTION 9.2: Install the Handing Harness

**Attention:** The Handing Harness is used for Right Handed Units only. Left Handed Units do not use a Handing Harness.

1. Connect the (Break Module Harness) Female Pin to the Male Pin Housing (Handing Harness)
2. Connect the (Break Module Harness) Male Pin Housing to the Female Pin (Handing Harness).



**Figure 25** Connect the Handing Harness

## CHAPTER 10: INSTALL THE OUTSWING ARM

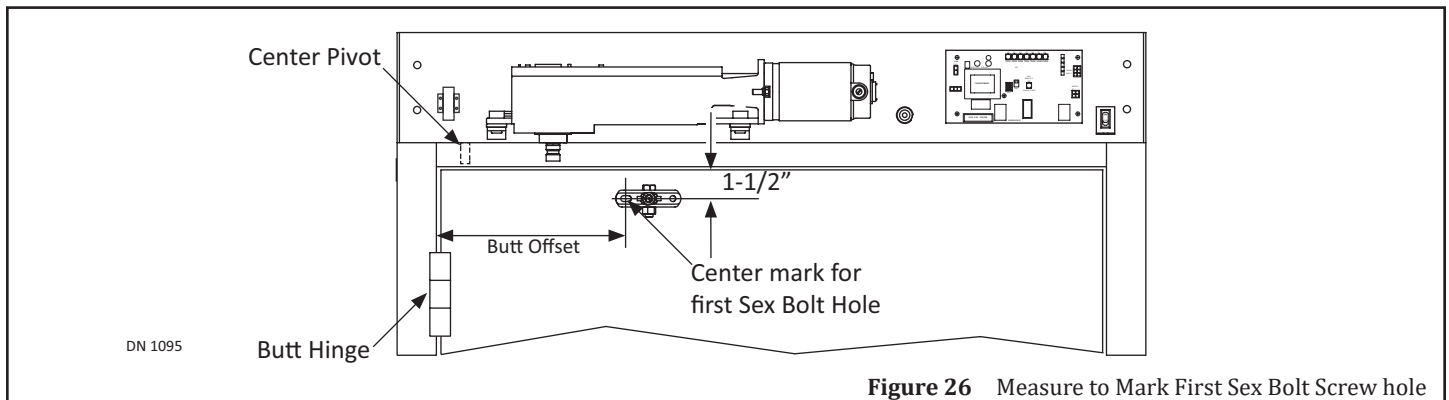
### SECTION 10.1: Prep the Swing Door

1. Measure and mark a Horizontal Line from the (Center Hinge or Butt Offset) to the center of the Face of Door according to Table 2.

**Table 2** Dimension "A" Arm Shoe Mounting Locations

Model	Pivot Type	Outswing	
		With Fingerguard	No Fingerguard
GT 400 & 8400	Butt/Offset	N/A	12-7/16"
	Center Pivot	16"	15"
GT 500 & 8500	Butt/Offset	N/A	10-3/16"
	Center Pivot	13-3/4"	12-3/4"
GT 600	Butt/Offset	N/A	12-7/16"
	Center Pivot	16"	15"

2. Measure 1 - 1/2 inches from the Bottom of Door Frame down to the Horizontal Line. Mark a Vertical line across the Horizontal Line. This is the center of the first Sex Bolt hole.
3. Butt the Arm Shoe against the Swing door by aligning the first Sex Bolt hole with the measured Mark.
4. Ensure the Arm Shoe is square and level.
5. Use the Arm Shoe as a Template to mark the second Sex Bolt hole. Set aside.



**Figure 26** Measure to Mark First Sex Bolt Screw hole

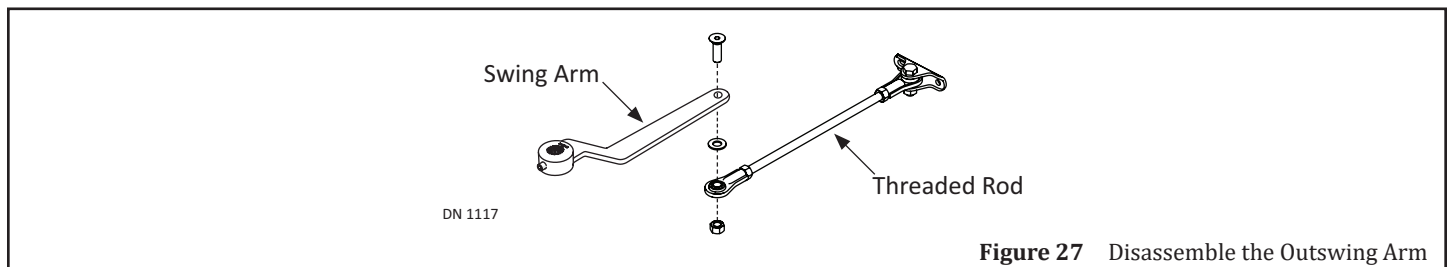
## SECTION 10.2: Prep the Outswing Arm Assembly

- Please refer to Table 3 to obtain the appropriate full length measurement of the Outswing Arm.

**Table 3** Full Length of Outswing Arm

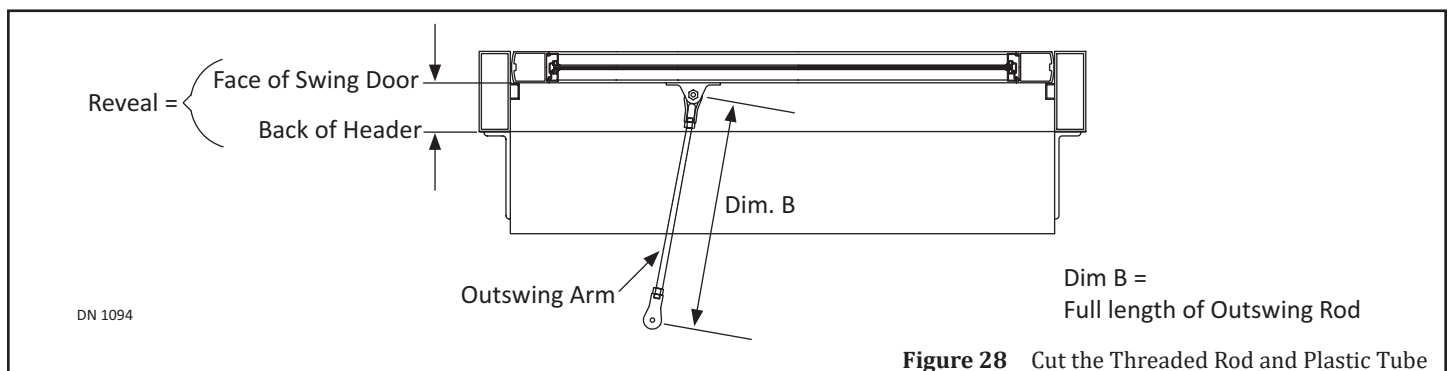
Model	Pivot Type	Reveal					
		1-1/8 inch	2-1/8 inch	3-1/8 inch	4-1/8 inch	5-1/8 inch	6-1/8 inch
GT 400 & 8400	Butt/Offset	11-7/8"	12-7/8"	13-7/8"	14-7/8"	15-7/8"	16-7/8"
	Center Pivot	12-1/2"	13-1/2"	14-1/2"	15-1/2"	16-1/2"	17-1/2"
GT 500 & 8500	Butt/Offset	11-7/8"	12-7/8"	13-7/8"	14-7/8"	15-7/8"	16-7/8"
	Center Pivot	11-7/8"	12-7/8"	13-7/8"	14-7/8"	15-7/8"	16-7/8"
GT 600	Butt/Offset	11-7/8"	12-7/8"	13-7/8"	14-7/8"	15-7/8"	16-7/8"
	Center Pivot	12-1/2"	13-1/2"	14-1/2"	15-1/2"	16-1/2"	17-1/2"

- Remove the Swing Arm from the Threaded Rod.



**Figure 27** Disassemble the Outswing Arm

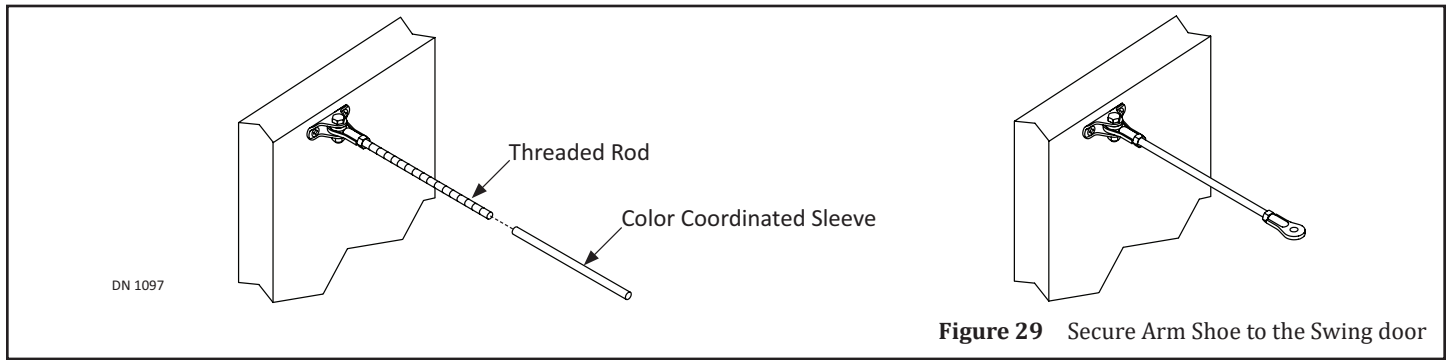
- Measure between the center of each Eye located at each end of the Outswing Rod.
- Write that measurement down.



Dim B =  
Full length of Outswing Rod

**Figure 28** Cut the Threaded Rod and Plastic Tube

- Cut the Threaded Rod until the appropriate Full Length measurement is achieved (according to Table 3).
  - The Threaded Rod will be approximately 1 inch shorter than the full length measurement.
  - For Reveals that are (0 inches thru 6-1/2 inches), a 20 inch Threaded Rod must be purchased.
  - For Reveals that are (6-3/4 inches and higher), a 30 inch Threaded Rod must be purchased.
- Obtain (1) color coordinated Plastic Tube from the Outswing Rod assembly.
- Cut the Plastic Tube to the same length as the exposed Rod (between the Links and Nuts).
- Slide the Plastic Tube over the Threaded Rod.
- Replace the Rod Link back onto the Threaded Rod.
- Tighten the Nut against the Link to prevent the Rod from screwing In or Out.



**Figure 29** Secure Arm Shoe to the Swing door

**SECTION 10.3: Secure the Arm Shoe to the Swing Door**

1. Butt the Arm Shoe against the Swing door. Align the first Sex Bolt hole to the measured Mark.
2. Ensure the Arm Shoe is square and level. Use the Arm Shoe as a Template to mark the second Sex Bolt hole. Set aside.
3. Drill (2) 3/8 inch bolt holes all the way through the Swing door.
4. Go to the back of the Swing door. Insert each Sex Bolt into the drilled holes.
5. Go to the front of the Swing door. Secure the Arm Shoe to the Swing Door with (2) 1/4-20 x 2-1/4" Screws.

**SECTION 10.4: Set Pre-Load**

**CAUTION**

**Power must be turned OFF during the Swing Arm installation.**

**DANGER**

**Ensure the Motor/Operator is plugged into the Controller. This needs to be done so the Swing Arm will not swing back as fast, if accidentally let go.**

**Notice:** *Note: On Low energy Operators (GT500,8500), minimum preload must be used.*

Full Energy 400/600/8400	Low Energy 500/8500
20 degrees to 140 degrees	20 degrees to 140 degrees
Not to exceed 15 to 30 pounds of closing force per ANSI 156.10	Not to exceed 15 pounds of closing force per ANSI 156.19

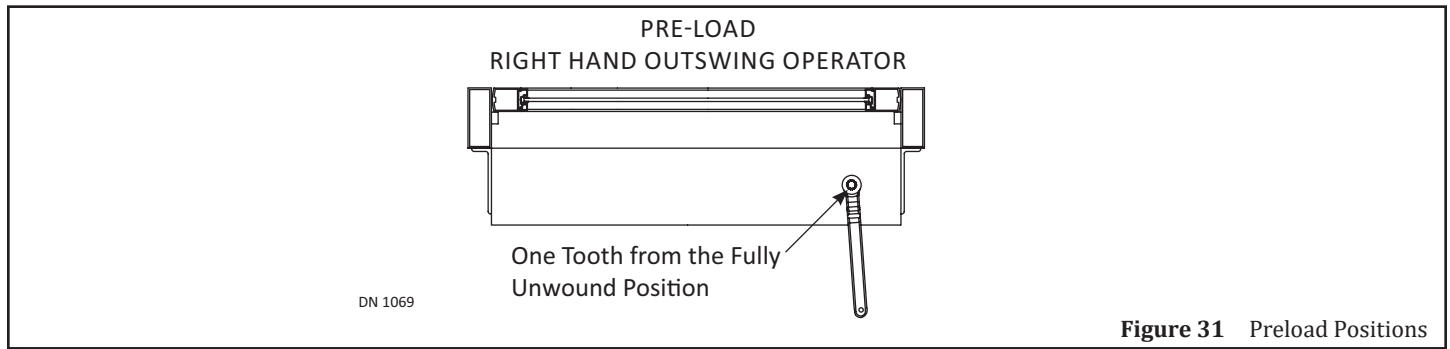
All GT8300/8400/8500 Swing Doors that utilize the Opus Control are shipped with ROF Operators. ROF Operators are identified by a green sticker with ROF written on it (located at the end of the Operator), and by a ROF stamp located on the Serial Number Decal.



**Figure 30** Locate the ROF Identification

**Notice:** **Since there are no micro-switches or cams, preloading ROF Operators is not as crucial. Greater preloads may be used to overcome wind, door seals, or stack pressure. But in most cases, minimal preload is all that's needed. Preload helps to ensure that the door is easy to open manually. However, in all cases, final adjustments must conform to the applicable ANSI standards.**

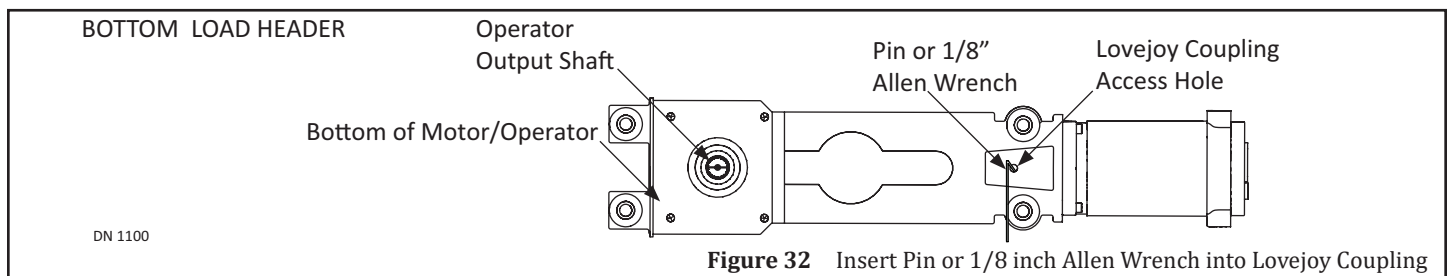
1. Ensure the Spring on the Operator is in the Unwound (Factory Shipped) position.
2. Obtain (1) Pin or 1/8 inch Allen Wrench. Go underneath the Header. Locate the Operator Spindle.
3. Slide the Swing Arm onto the Spindle so it is (1) Tooth from the fully unwound position.
4. With a firm grip, from the Unwound (0 degree) position, rotate the Swing Arm approximately 20 - 140 degrees.
  - a. On GT500/8500 rotate the arm no more than (1) Tooth on the operator output shaft. (1) Tooth equals 20 degrees.



**Figure 31** Preload Positions

**DANGER**

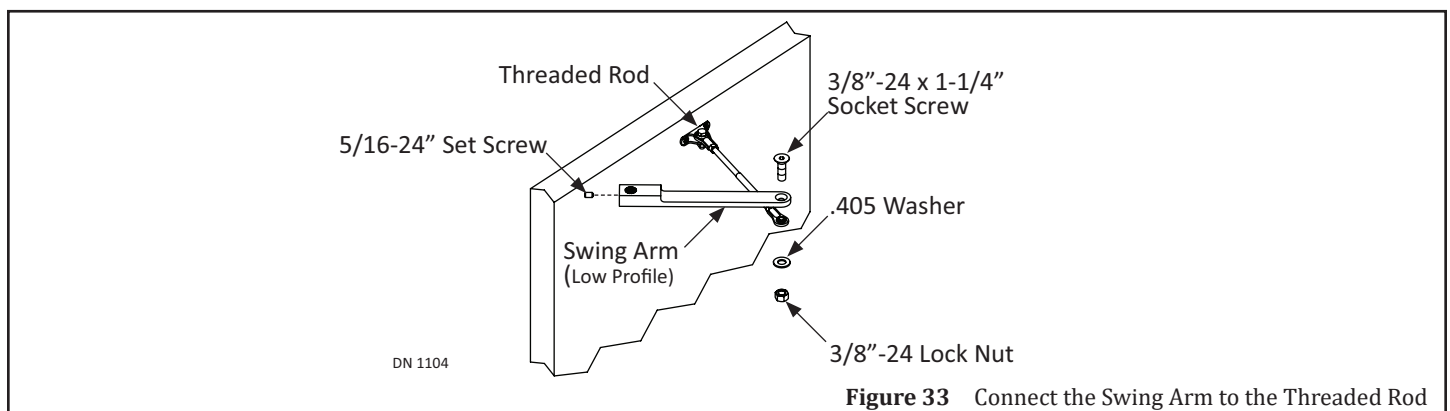
Do not allow the Pin or 1/8 inch Allen Wrench to drop out of the Lovejoy Coupling Access hole at any time during installation. The Swing Arm will spring back to its original location and can result in personal injury or damage.



**Figure 32** Insert Pin or 1/8 inch Allen Wrench into Lovejoy Coupling

**SECTION 10.5: Secure the Outswing Arm to Door**

1. Align the Screw hole at the end of Swing Arm to the Screw hole at the end of Threaded Rod.
  - a. It may be necessary to remove and then slide the Swing Arm back onto the Operator Spindle.
2. Secure the Swing Arm to the Threaded Rod with (1) 3/8"-24 x 1-1/4" Socket Screw, (1) .405 Washer, and (1) 3/8"-24 Lock Nut.



**Figure 33** Connect the Swing Arm to the Threaded Rod

## CHAPTER 11: INSTALL THE INSWING ARM

### SECTION 11.1: Secure Guide Track

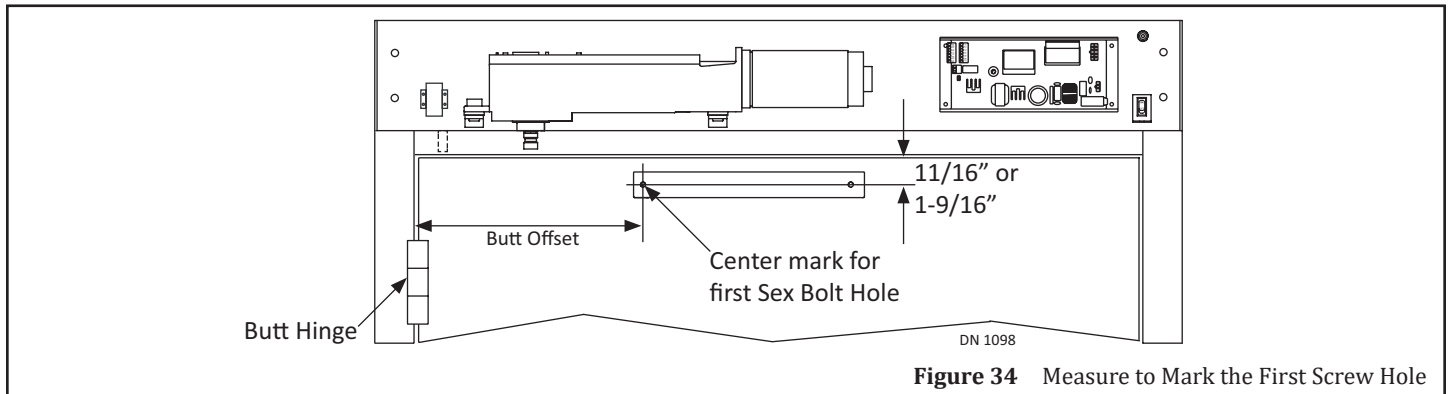
1. Measure and mark a Horizontal Line from Center Hinge or Butt Offset to the center of the Face of Door according to Table 4.

**Table 4** Track Mounting Locations

Model	Pivot Type	Inswing Standard Track (ST) 12-1/4"		Inswing Standard Track (PT) 21"	
		With Fingerguard	No Fingerguard	With Fingerguard	No Fingerguard
GT 400 & 8400	Butt/Offset	N/A	8-1/4"	N/A	N/A
	Center Pivot	13"	12"	3-3/4"	2-3/4"
GT 500 & 8500	Butt/Offset	N/A	8-1/4"	N/A	N/A
	Center Pivot	13-3/4"	12"	3-3/4"	2-3/4"
GT 600	Butt/Offset	N/A	8-1/4"	N/A	N/A
	Center Pivot	13"	12"	3-3/4"	2-3/4"

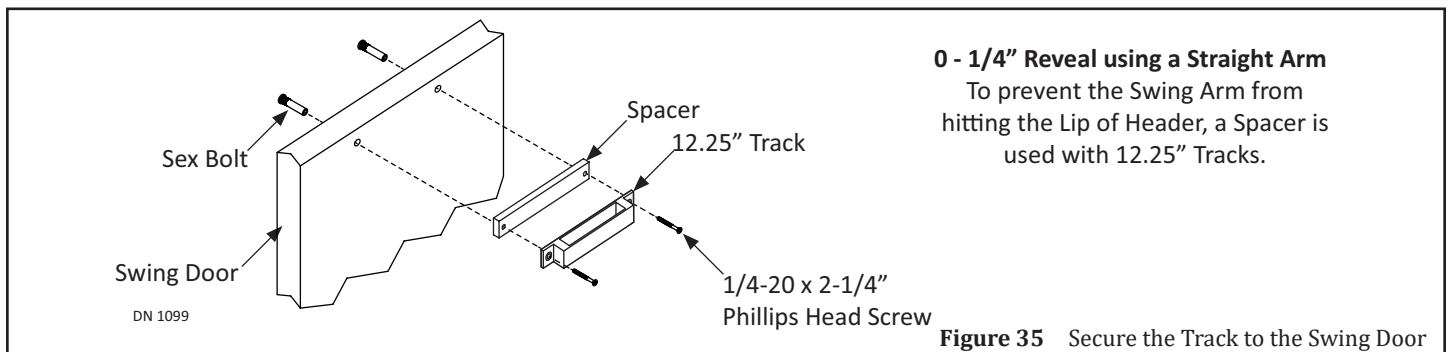
#### 11.1.1: Reveal Greater than Zero

1. Measure:
  - ▶ Straight Arm: 11/16 inch from the Bottom of Door Frame down to the Horizontal Line. Mark a vertical line across the Horizontal Line. This is the center of the first Sex Bolt hole.
  - ▶ L-Shape Arm: 1-9/16 inch from the Bottom of Door Frame down to the Horizontal Line.
  - ▶ For dimensions not shown (L-Shape Arm): Reveal + 8-7/8 inch = New dimension



**Figure 34** Measure to Mark the First Screw Hole

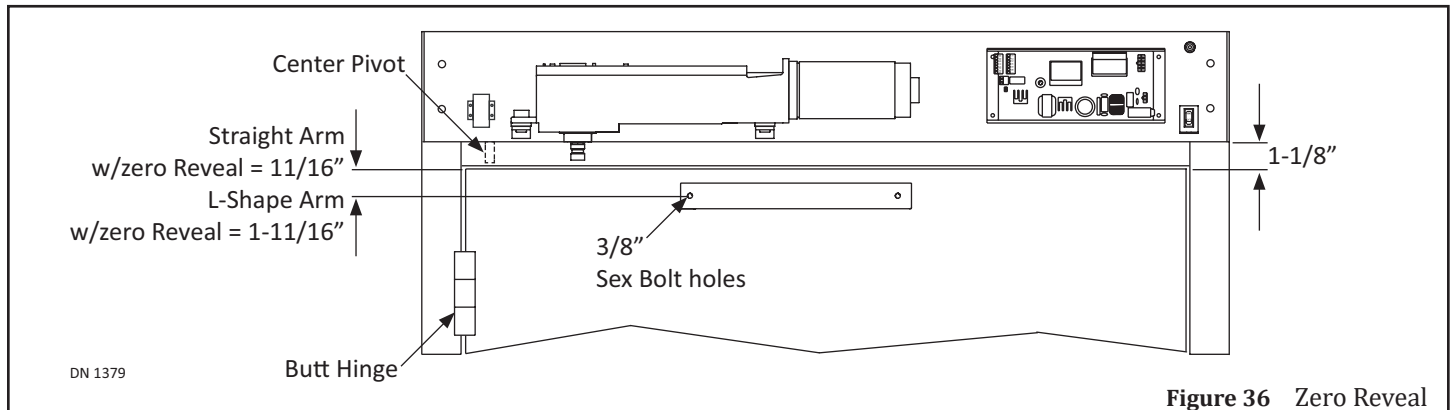
2. Butt the Guide Track against the Swing door by aligning the first Sex Bolt hole with the measured Mark.
3. Ensure the Guide Track is square and level. Use the Track as a Template to mark the second Sex Bolt hole. Set aside.
4. Drill (2) 3/8 inch bolt holes all the way through the Swing door.
5. Go to the back of the Swing door. Insert each Sex Bolt into the drilled holes.
6. Go to the front of the Swing door. Butt the Track against the Swing door by aligning the Sex Bolt holes.
  - a. Install (1) Spacer behind the Track for Swing doors with "0" Reveal.
7. Secure the Guide Track to the Swing Door with (2) 1/4-20 x 2-1/4" Screw.



**0 - 1/4" Reveal using a Straight Arm**  
To prevent the Swing Arm from hitting the Lip of Header, a Spacer is used with 12.25" Tracks.

**Figure 35** Secure the Track to the Swing Door

### 11.1.2: Zero Reveal

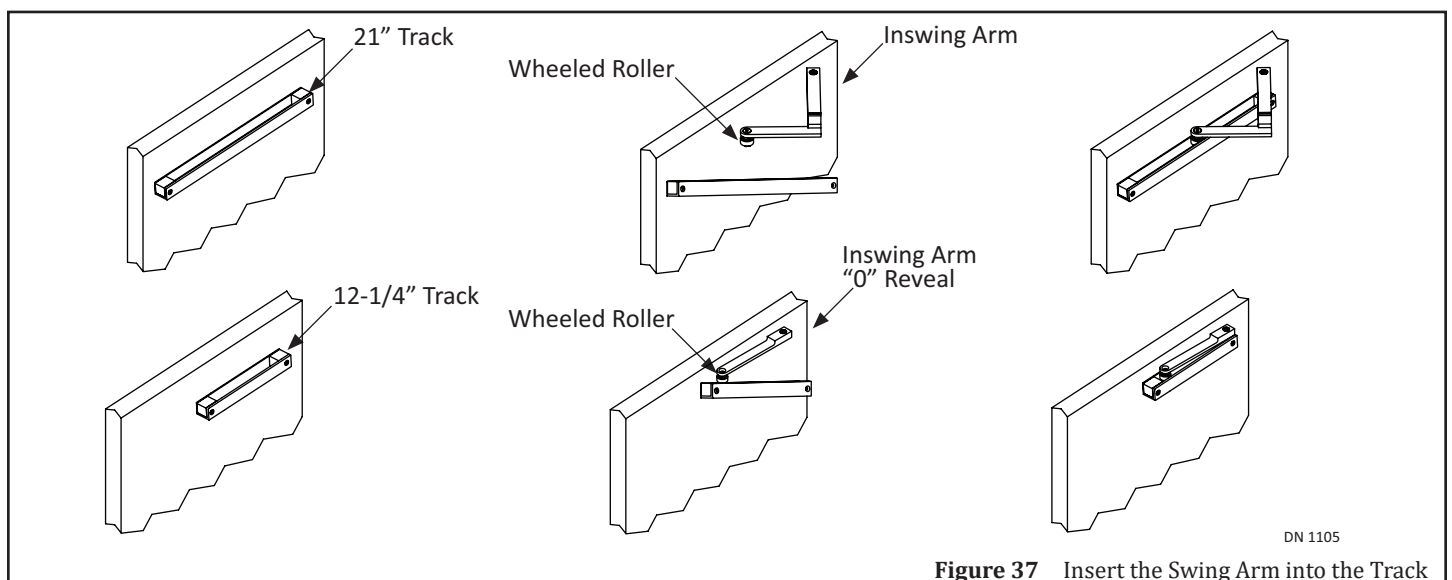


**Figure 36** Zero Reveal

*Note:* For zero Reveal applications the Straight Arm can be used to eliminate the Arm protruding into the room.

- ▶ Straight Arm: Measure  $11/16$  inch from the Bottom of Door Frame down to the Horizontal Line.
- ▶ L-Shape Arm: Measure  $1-11/16$  inch from the Bottom of Door Frame down to the Horizontal Line.

### SECTION 11.2: Secure the Inswing Arm to Door



**Figure 37** Insert the Swing Arm into the Track

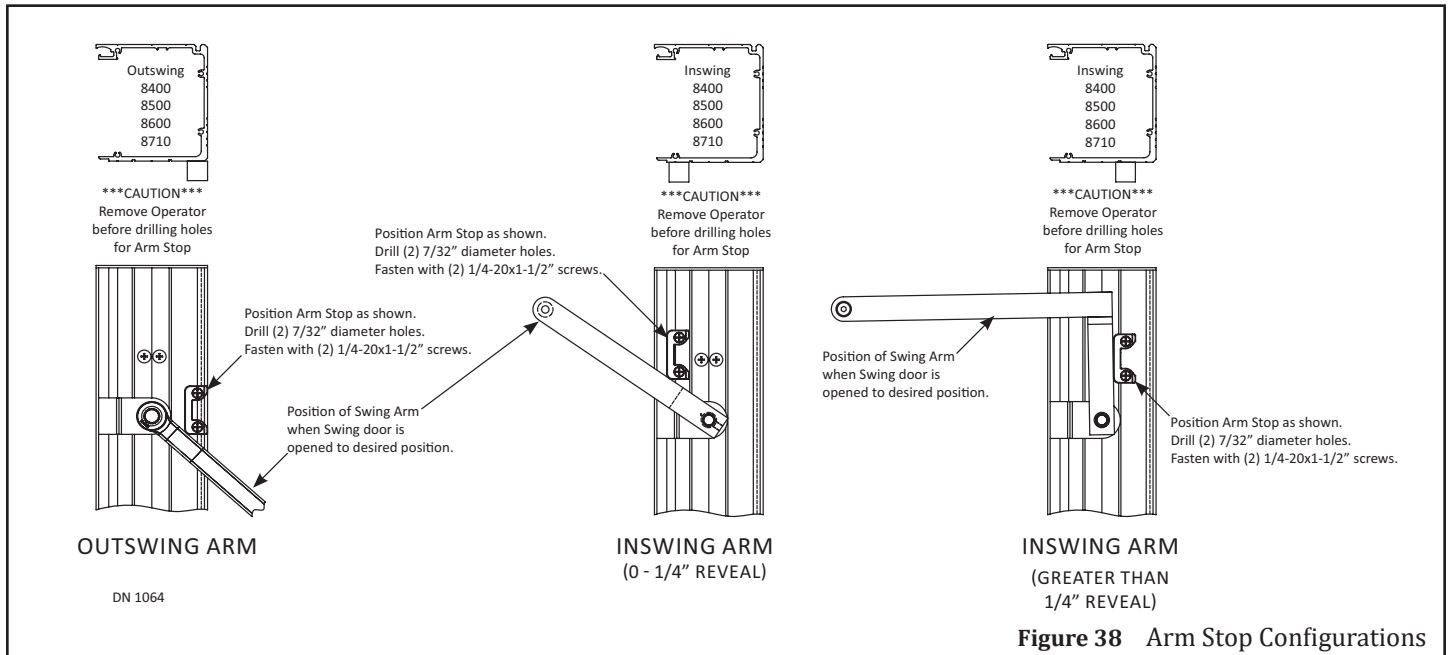
1. Remove the first  $1/4-20 \times 2-1/4''$  Screw (closest to the Pivot Door Jamb) that is used to secure the Track to the Swing door, so that side of the Track will hang down.
2. Close the Swing door to allow the Wheeled Roller (located at the end of the Swing Arm) to butt against the Swing door.
3. Raise the Track until the screw hole is aligned with the screw hole on the Swing door.
  - a. The Wheeled Roller will insert itself into the Track.
4. Secure the Track to the Swing door with (1)  $1/4-20 \times 2-1/4''$  Screw.
5. Secure the Swing Arm to the Operator Spindle with (1) Set Screw. Tighten but do not overtighten.
  - a. Ensure the Set Screw is seated correctly within the groove on the Operator Spindle.
6. Remove the (Pin or  $1/8$  inch) Allen Wrench.

# CHAPTER 12: INSTALL THE ARM STOP (SIDE LOAD UNITS)

## CAUTION

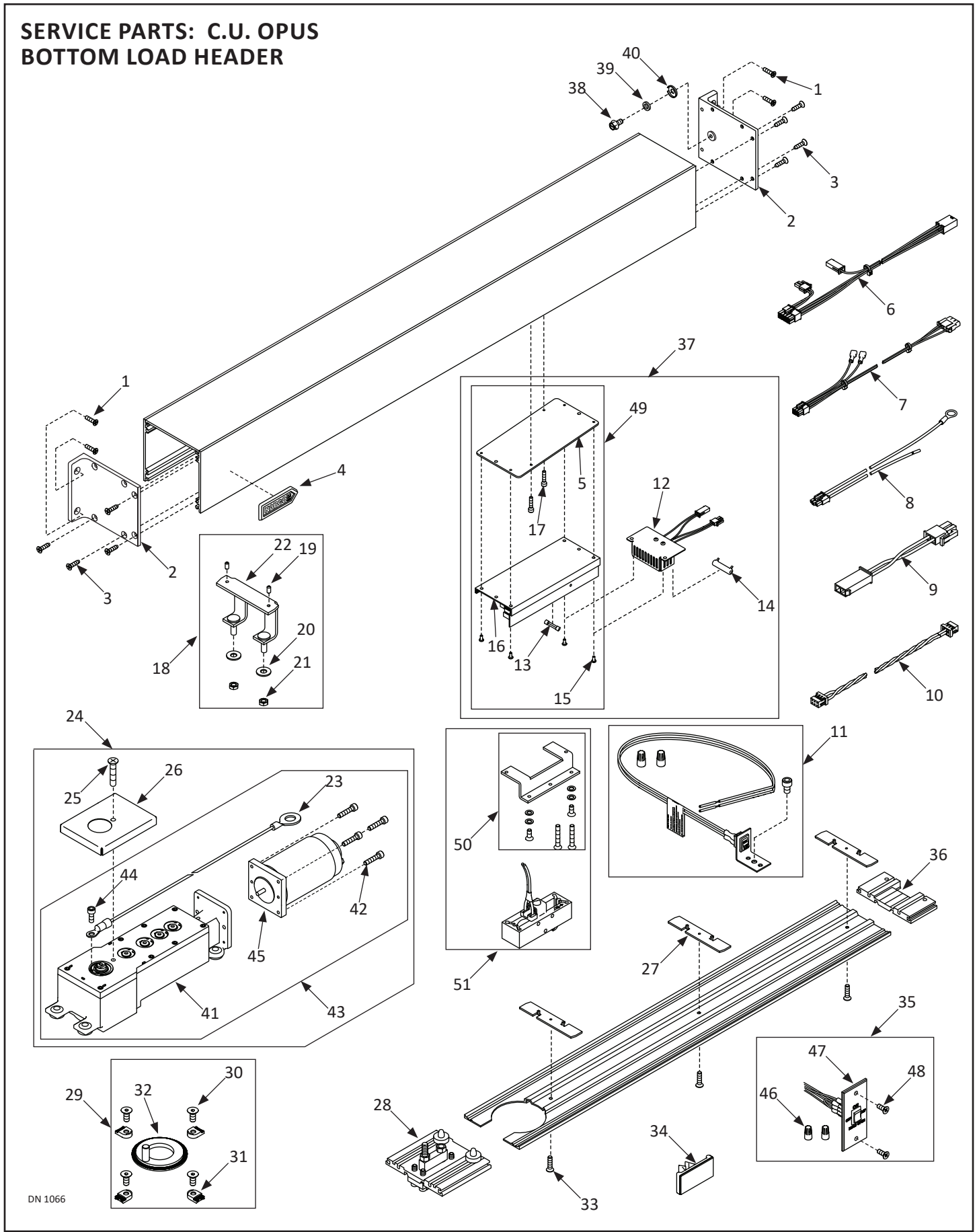
**Do Not drill screw holes for the Arm Stop into the Motor/Operator!!!**

1. Open the Swing Door 90 degrees.
2. Obtain the Parts Bag that includes (1) Arm Stop and (2) 1/4-20 inch Self Tapping screws.
3. Position the Arm Stop at the bottom of Header according to type of Swing Arm and Reveal shown in Figure 39.
4. Use the Arm Stop as a template to mark and drill (2) 7/32 inch diameter screw holes.
5. Secure the Arm Stop with (2) 1/4-20 inch Self Tapping screws.



**Figure 38** Arm Stop Configurations

### SERVICE PARTS: C.U. OPUS BOTTOM LOAD HEADER



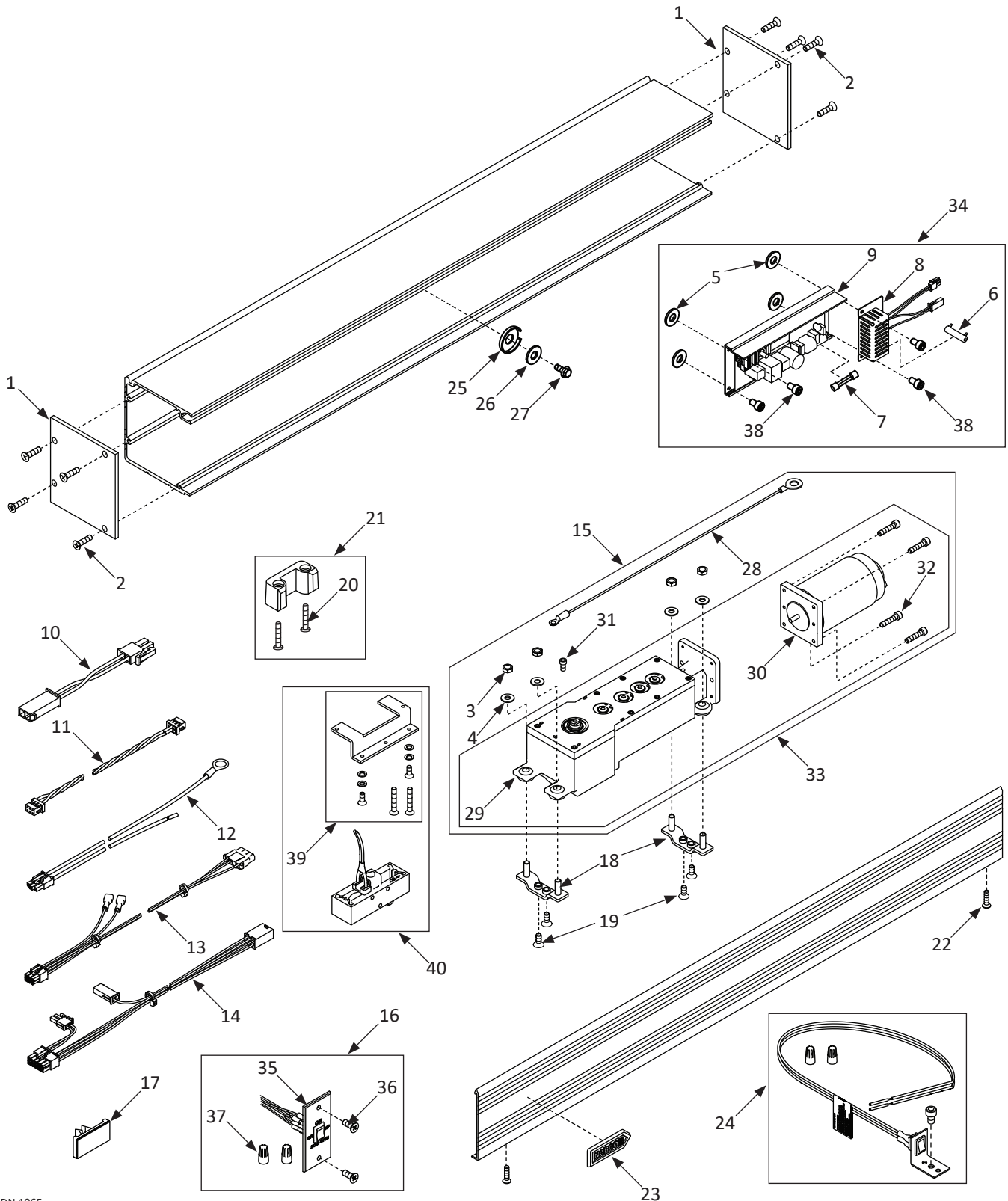
DN 1066



Opus Bottom Load Header			
Item	Part	Finish/Sizes/Notes	Description
1	T-00294		FHMS,1/4-20x1.000L.,PHIL,ZN
2	A-60733	Clear	BRACKET,END CAP,C.U.,204
	A-70733	Dark Bronze	BRACKET,END CAP,C.U.,313
3	T-00061		FHMS,1/4-20x1.000L.,PHIL,TRI-LOBE,ZINC
4	C-00067		NAMEPLATE,NABCO LOGO
5	M-01735		PLATE,BOTTOM LOAD,OPUS
6	A-01000	Not used on GT710/8710	HARNESS,MOTOR,OPUS
7	A-01002	Retrofit Kits Only	HARNESS,ADAPTER,NON-ENCODER,OPUS
8	M-01072		HARNESS,POWER,MAGNUM/OPUS
9	A-01001	Not used on GT710/8710	HARNESS,HANDING,OPUS
10	M-01680	Simultaneous Pair	HARNESS,SIM PAIR,OPUS
11	A-00409		PARTS BAG,ON/OFF,SWINGER,SWITCH
12	A-01003		MODULE,BRAKE,OPUS
13	V-00552	Used on Opus Control	FUSE;5A;GMA;5X20mm
14	V-00411	Used on Brake Module	RESISTOR,200 OHM,20 WATT
15	T-00420		PHMS,8-32x0.375L,PHIL,SWAGEFORM,ZINC
16	M-01546		CONTROLLER,OPUS
17	T-00232		SHCS,10-24x0.875L.,ZINC
18	A-00501		BRKT.;MOTOR;REAR;BTM.LOAD
19	T-00073		SHSS,1/4-20x0.500L.,KNURL PT.
20	T-00092		WASHER,.438 ID,1.00 OD,.083 THK,ZINC
21	T-00067		NUT,HEX,JAM,3/8-16,ZINC
22	M-01181		TOP FRAME MOUNT, SUB - ASSY - SWINGER
23	A-00620		GROUND WIRE:SWING OPERATOR:MAGNUM
24	A-01093	RH	"OPER.SWGR,W/ENCOD,ROF;RH;NO CLUTCH;B-LO
	A-01092	LH	"OPER.SWGR,W/ENCOD.ROF;LH;NO CLUTCH;B-LO
25	T-00238		FHMS,10-24x1.000L.,PHIL,ZINC
26	A-00348		COVER,SWITCH,SWINGER
27	M-01177		LOCK COVER PLATE - BOTTOM
28	A-60731	Clear/Out	BASE PIVOT,C.U.,OUTSWING,204
	A-70731	Dark Bronze/Out	BASE PIVOT,C.U.,OUTSWING,313
	A-60738	Clear/In	BASE PIVOT,C.U.,IN/OUTSWING,2-1/2",204
	A-70738	Dark Bronze/In	BASE PIVOT,C.U.,IN/OUTSWING,2-1/2",313
29	A-00489		STOP,RING ASSY
30	T-00334		FHMS:5/16-18x0.750L.:SOKT:ZN
31	M-01159		RING, STOP - HOLD DOWN
32	M-01475		LIMIT STOP:C.U.
33	T-00391		FHMS,10-24x0.750L.,PHIL,ZINC
34	V-00098		SADDLE, WIRE
35	A-00805		SWITCH,ROCKER,SWINGER,ON/OFF/HOLD OPEN
36	A-61176	Clear	CU - SGL STRIKE BASE 3-1/4,204
	A-71176	Dark Bronze	CU - SGL STRIKE BASE 3-1/4,313

Opus Bottom Load Header			
Item	Part	Finish/Sizes/Notes	Description
37	A-01098		CONTROLLER,W/ BRAKE,BOTTOM LOAD,OPUS
38	T-00346		HHCS:1/4-20x0.375L:GREEN:WASH HD:SLOT
39	M-00450		SPACER,MTG.END CAP
40	V-00104		WASHER, CUP.312 ID X .88 OD X .040 THICK
41	A-01053	RH	OPER. SWINGER,W/O MTR.,NO CLUTCH,RH;ROF
	A-01052	LH	OPER. SWINGER,W/O MTR.,NO CLUTCH,LH;ROF
42	T-00103		SHCS,10-24x0.875L.,W-LOCK PATCH
43	A-00824	RH	OPERATOR,SWGR,W/ENCODER, RH CLUTCHLESS
	A-00823	LH	OPERATOR,SWGR,W/ENCODER, LH CLUTCHLESS
44	T-00185		SHCS,10-24x0.500L.,BK.OX.
45	V-00090		MOTOR,SHORT FRAME,ENCODER,DUOWEI
46	T-00197		NUT,WIRE,RANGE 22-14AWG,GREY
47	M-01576		SWITCHPLATE,ON/OFF/HOLD OPEN
48	T-00031		FHMS,10-32x0.500L.,PHIL,UCUT,T-LOBE,BKZN
49	A-01143		CONTROLLER,W/O BRAKE,BOTTOM LOAD,OPUS
50	A-00491	Clear	BRACKET,MOUNTING ,PANIC,LATCH 204
	A-70491	Dark Bronze	BRACKET,MOUNTING ,PANIC,LATCH 313
51	A-00419	Clear	KIT,PANIC LATCH,CU,204
	A-70419	Dark Bronze	KIT,PANIC LATCH,CU,313

# SERVICE PARTS: C.U. OPUS SIDE LOAD HEADER



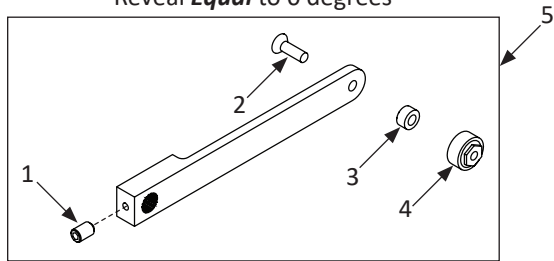
DN 1065

Opus Side Load Header			
Item	Part	Finish/Sizes/Notes	Description
1	M-01051	Clear	END CAP,SIDELOAD HDR,84-8500 4HOLE,204
	M-71051	Dark Bronze	END CAP,SIDELOAD,NO ACCESS HOLE,313
2	T-00016	Clear	FHMS,1/4-20x0.438L.,PHIL,UNDERCUT,ZINC
	T-00108	Dark Bronze	FHMS,1/4-20x0.438L.,PHIL,UNDERCUT,BLK ZN
3	T-00067		NUT,HEX,JAM,3/8-16,ZINC
4	T-00092		WASHER,.438 ID,1.00 OD,.083 THK,ZINC
5	T-00365		WASHER,.170 ID,.625 OD,.032 THK,NYLON
6	V-00411	Used on Brake Module	RESISTOR,200 OHM,20 WATT
7	V-00552	Used on Opus Control	FUSE;5A;GMA;5X20mm
8	A-01003		MODULE,BRAKE,OPUS
9	M-01546		CONTROLLER,OPUS
10	A-01001	Not used on GT710/8710	HARNES,HANDING,OPUS
11	M-01680	Simultaneous Pair	HARNES,SIM PAIR,OPUS
12	M-01072		HARNES,POWER,MAGNUM/OPUS
13	A-01002	Retrofit Kits Only	HARNES,ADAPTER,NON-ENCODER,OPUS
14	A-01000	Not used on GT710/8710	HARNES,MOTOR,OPUS
15	A-01091	RH	"OPER.SWGR,W/ENCOD,ROF;RH;NO CLUTCH;S-LO
	A-01090	LH	"OPER.SWGR,W/ENCOD.ROF;LH;NO CLUTCH;S-LO
16	A-00805		SWITCH,ROCKER,SWINGER,ON/OFF/HOLD OPEN
17	V-00098		SADDLE, WIRE
18	M-01043		BRACKET, OPERATOR, SIDELOAD HEADER
19	T-00334	Clear	FHMS:5/16-18x0.750L.:SOKT:ZN
	T-00370	Dark Bronze	FHMS:5/16-18x0.750L.:SOKT:BK.ZN
20	T-00325		PHMS, 1/4-20X1.500L, PHIL, TYPE F
21	A-00454		ARM STOP,ASSEM FOR 400, 8400, 500, 8500
22	T-00337		PHSMS:#8x0.625L.:PHIL
23	C-00067		NAMEPLATE,NABCO LOGO
24	A-00409		PARTS BAG,ON/OFF,SWINGER,SWITCH
25	V-00104		WASHER, CUP.312 ID X .88 OD X .040 THICK
26	T-00029		WASHER,.250 ID,.563 OD,.049 THK,ZINC
27	T-00347		HHCS:10-32x0.375L:GREEN:WASH HD:SLOT
28	A-00620		GROUND WIRE:SWING OPERATOR:MAGNUM
29	A-01053	RH	OPER. SWINGER,W/O MTR.,NO CLUTCH,RH;ROF
	A-01052	LH	OPER. SWINGER,W/O MTR.,NO CLUTCH,LH;ROF
30	V-00090		MOTOR,SHORT FRAME,ENCODER,DUOWEI
31	T-00185		SHCS,10-24x0.500L.,BK.OX.
32	T-00103		SHCS,10-24x0.875L.,W-LOCK PATCH
33	A-00824	RH	OPERATOR,SWGR,W/ENCODER, RH CLUTCHLESS
	A-00823	LH	OPERATOR,SWGR,W/ENCODER, LH CLUTCHLESS
34	A-00888		CONTROLLER,W/ BRAKE,SIDELOAD,OPUS
35	M-01576		SWITCHPLATE,ON/OFF/HOLD OPEN
36	T-00031		FHMS,10-32x0.500L.,PHIL,UCUT,T-LOBE,BKZN

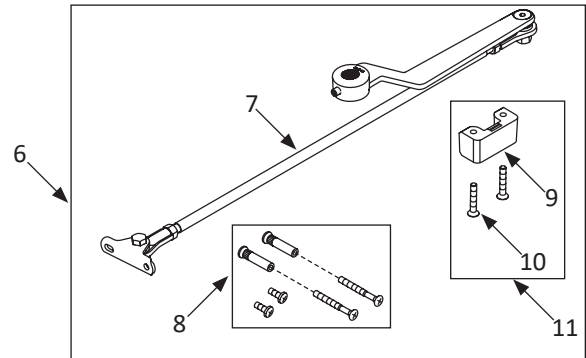
Opus Side Load Header			
Item	Part	Finish/Sizes/Notes	Description
37	T-00197		NUT,WIRE,RANGE 22-14AWG,GREY
38	T-00335		SHCS,10-24x0.313L.,ZINC
39	A-00491	Clear	BRACKET,MOUNTING ,PANIC,LATCH 204
	A-70491	Dark Bronze	BRACKET,MOUNTING ,PANIC,LATCH 313
40	A-00419	Clear	KIT,PANIC LATCH,CU,204
	A-70419	Dark Bronze	KIT,PANIC LATCH,CU,313

### SERVICE PARTS: SWING ARM ASSEMBLIES

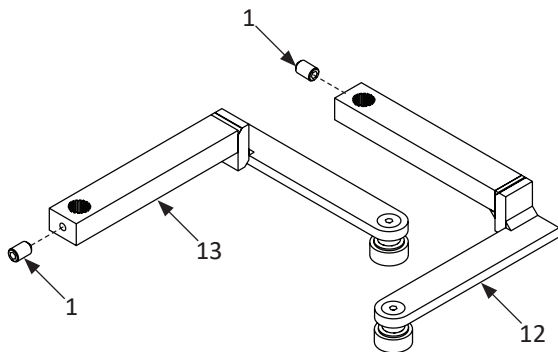
Inswing Arm  
Reveal **Equal** to 0 degrees



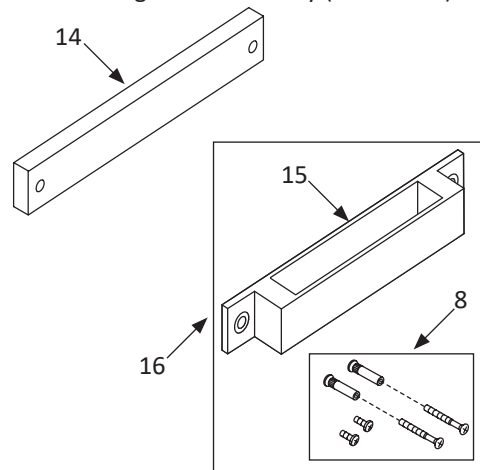
Outswing Arm Assembly



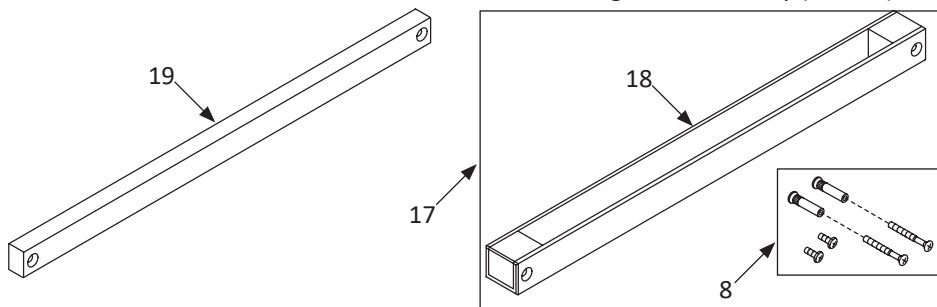
(CU) Inswing Arm Assembly  
Reveal Greater than 0 inches



Inswing Track Assembly (12.25 inch)



Inswing Track Assembly (21 inch)



DN 1073

Swing Arm Assemblies			
Item	Part	Finish/Sizes/Notes	Description
1	T-00261		SHSS,5/16-24x0.500L.,CUP PT.
2	T-00223		FHCS,3/8-24x1.250L.,ZINC
3	M-01045		WASHER,STEEL,.375IDx.75ODx.375"THK.
4	A-00752		ROLLER,REPLACEMENT
5	A-60545	Clear	ARM,INSWING,CU,NON PANIC,NH,204
	A-70545	Dark Bronze	ARM,INSWING CU,NO PANIC,NH 313
6	A-60786	Clear	ARM,OUTSWING,CU.,20in,204,W-STOP
	A-70786	Dark Bronze	ARM,OUTSWING,CU.,20in,313,W-STOP
	A-60787	Clear	ARM,OUTSWING,,C.U.,30in,204,W-STOP
7	A-70787	Dark Bronze	ARM,OUTSWING,CU.,30in,313,W-STOP
	A-60425	Clear	ARM,OUTSWING,STD ASM,20in,204
	A-70425	Dark Bronze	ARM:OUTSWING:STD ASM:20",313
	A-60426	Clear	ARM,OUTSWING,STD ASM,30in,204
8	A-70426	Dark Bronze	ARM:OUTSWING:STD ASM:30",313
	A-00389	Clear	PARTS BAG,SEX BOLTS & HARDWARE,204
9	A-00388	Dark Bronze	PARTS BAG,SEX BOLTS & HARDWARE,313
10	M-01080		ARM STOP, 710
11	T-00325		PHMS, 1/4-20X1.500L, PHIL, TYPE F
12	A-00471		KIT, GT710 PARTS
	A-60658	RH/Clear	INSWING ARM,0 TO 2" REV,RH,204
	A-70658	RH/Dark Bronze	INSWING ARM:7-3/4":RH:313
	A-60671	RH/Clear	INSWING ARM,2 TO 5-1/2" REV,RH,204
	A-70671	RH/Dark Bronze	INSWING ARM:11-1/2":RH:313
	A-60672	RH/Clear	INSWING ARM5-1/2 TO 9-3/4" REV,RH,204
	A-70672	RH/Dark Bronze	INSWING ARM:15-3/4":RH:313
13	A-60673	RH/Clear	INSWING ARM,9-3/4 TO 13" REV,RH,204
	A-70673	RH/Dark Bronze	INSWING ARM:20-1/2":RH:313
	A-60675	LH/Clear	INSWING ARM,0 TO 2" REV,LH,204
	A-70675	LH/Dark Bronze	INSWING ARM:7-3/4":LH:313
	A-60676	LH/Clear	INSWING ARM,2 TO 5-1/2" REV,LH,204
	A-70676	LH/Dark Bronze	INSWING ARM:11-1/2":LH:313
14	A-60677	LH/Clear	INSWING ARM,5-1/2 TO 9-3/4",LH,204
	A-70677	LH/Dark Bronze	INSWING ARM:15-3/4":LH:313
15	A-60678	LH/Clear	INSWING ARM,9-3/4 TO 13" REV,LH,204
	A-70678	LH/Dark Bronze	INSWING ARM:20-1/2":LH:313
16	A-00952	12.25" Long	SPACER,INSWING TRACK
17	A-60536	Clear	GUIDE TRACK,C.U.,12.25"L,204
	A-70536	Dark Bronze	GUIDE TRACK,C.U.,SUB-ASSY,12.25"
18	A-60639	Long/Clear	TRACK,INSWING,10",204
	A-70639	Long/Dark Bronze	TRACK,INSWING,10",313
19	A-00481	Clear	TRACK,INSWING,21 LG,204
	A-70481	Dark Bronze	TRACK,INSWING,21 LG,313

A-60435	Clear	C.U. GUIDE TRACK,21”L,204
A-70435	Dark Bronze	C.U. GUIDE TRACK,21” L,313
M-02045	21” Long	SPACER,INSWING TRACK,LONG,710