



GT2100 Full Open, no Track Self Close Slide Door

Installation Manual

P/N C-00094 Rev 1-22-19

Nabco Entrances Inc. S82 W18717 Gemini Drive Muskego, Wisconsin 53150
Phone: (877) 622-2694 Fax: (888) 679-3319 www.nabcoentrances.com
NABCO hours of Operation: Monday to Friday 8:00 a.m.- 4:30 p.m. (Central Time)

*Associated Manuals Part Numbers: Manual Slide Door Owner's Manual (P/N C-00189) for Decal Installation
NABCO Price Book" for Sensors, Switches, and Accessories (P/N 16-9244-30)*

Table of Contents

CHAPTER 1: WARNING LABELS	3
CHAPTER 2: GENERAL SAFETY RECOMMENDATIONS	3
CHAPTER 3: SCOPE	3
SECTION 3.1: To the Installer	3
SECTION 3.2: Objective	4
CHAPTER 4: GETTING STARTED	4
SECTION 4.1: Type of Unit	4
SECTION 4.2: Power Requirements (for Hold Open Option)	4
SECTION 4.3: Inspect the Rough Opening	4
CHAPTER 5: ASSEMBLE DOOR FRAME	5
CHAPTER 6: SECURE DOOR FRAME TO BUILDING	6
SECTION 6.1: Prepare Door Frame	6
SECTION 6.2: Secure Door Frame to Building	6
CHAPTER 7: INSTALL THE FULL OPEN SIDELITE	7
SECTION 7.1: Install the Bottom Pivot	7
SECTION 7.2: Insert Pivot Pins into Pivots	7
SECTION 7.3: Adjust Door Height	8
SECTION 7.4: Prepare the Header for the Flush Bolt	8
SECTION 7.5: Install the Bottom Guide	9
CHAPTER 8: INSTALL THE SLIDE DOOR	9
SECTION 8.1: Wire the Rocker Switch and Electromagnet	9
SECTION 8.2: Lift Carrier onto Track	10
SECTION 8.3: Align the Rotary Damper to the Control Rack	11
SECTION 8.4: Attach the Pull Spring to the Carrier	11
SECTION 8.5: Align Slide Door with Electromagnet and Door Stop Bumper	11
SECTION 8.6: Adjust the Closing Speed	12
SECTION 8.7: Fine Tune the Latching Speed	13
SECTION 8.8: Adjust Height on Slide Door	13
CHAPTER 9: INSTALL WEATHERING	13

CHAPTER 10: INSTALL THE GLASS STOPS.	14
SECTION 10.1: Glass Stops for Door Panels	14
CHAPTER 11: GLAZING (HEAVY/WIDE DOORS).	14
CHAPTER 12: ADJUSTMENTS.	15
SECTION 12.1: Adjust Height on Slide Door	15
SECTION 12.2: Correct Preload Misalignment	15
SECTION 12.3: Adjust the Nose Caster.	16
SERVICE PARTS: KIT	17
SERVICE PARTS: HEADER	18
SERVICE PARTS: CARRIER	20
SERVICE PARTS: FULL OPEN SIDELITE	21
SERVICE PARTS: RIGHT HAND FULL OPEN SIDELITE	22
SERVICE PARTS: LEFT HAND FULL OPEN SIDELITE	23
SERVICE PARTS: SLIDE DOOR	26
SERVICE PARTS: RIGHT HAND SLIDE DOOR	27
SERVICE PARTS: LEFT HAND SLIDE DOOR	28

CHAPTER 1: WARNING LABELS

Warning labels are universal and used to alert an individual of potential harm to one's self or to others. The following warning labels are listed in a hierarchy order that defines the most potential danger first, and the least potential danger last. Please refer to this page in the event that a warning label is displayed within this manual and further definition needs to be explained.

DANGER

Indicates potentially dangerous situations. Danger is used when there is a hazardous situation where there is a *high* probability of severe injury or death. It should not be considered for property damage unless personal injury risk is present.

WARNING

Indicates a hazardous situation which has *some* probability of severe injury. It should not be considered for property damage unless personal injury risk is present.

CAUTION

Indicates a hazardous situation which *may result in a minor injury*. Caution should not be used when there is a possibility of serious injury. Caution should not be considered for property damage accidents unless a personal injury risk is present.

Attention: A situation where material could be damaged or the function impaired.

Notice: Indicates a statement of company policy as the message relates to the personal safety or protection of property. Notice should not be used when there is a hazardous situation or personal risk.

Note: Indicates important information that provides further instruction.

CHAPTER 2: GENERAL SAFETY RECOMMENDATIONS

DANGER

Disconnect all power to the junction box prior to making any electrical connections. Failure to do so may result in serious personal or fatal injury. When uncertain whether power supply is disconnected, always verify using a voltmeter.

WARNING

Do not install, operate or service this product unless you have read and understand the General Safety Recommendations, Warning Labels, contained in this manual. Failure to do so may result in bodily injury, or property damage.

WARNING

Read, study and understand the installation and operating instructions contained in, or referenced in this manual before operating. If you do not understand the instruction, ask a qualified technician. Failure to do so may result in bodily injury, or property damage and will nullify all warranties.

CAUTION

If the door appears broken or does not seem to work correctly, it should be immediately removed from service until repairs can be carried out or a qualified service technician is contacted for corrective action.

Notice: This manual, the owner's manual and all other associated manuals must be given to and retained by the purchasing facility or end user.

CHAPTER 3: SCOPE

SECTION 3.1: To the Installer

The purpose of this manual is to familiarize the installer and purchaser with the proper installation and operation of this system. It is essential that this equipment be properly installed and operational before the door is used by the public. In the United States ANSI Standard Z97.1 covers Glass Installation. It is the installer's responsibility to inspect the operation of the entrance system to be sure it complies with any applicable standards.

Instruct the building owners and operator on the essentials of the operation of the door and this device. The owner should follow these instructions to determine whether the door is operating properly and should immediately call for service if there is any malfunction. All installation changes and adjustments must be made by qualified, NABCO trained technicians.

Note: As an Option, the GT-2100 Manual Slide door can be certified to have a Smoke and Air Infiltration NFPA-105 rating for sprinklered buildings (in the United States only).

SECTION 3.2: Objective

The GT-2100 is designed to be installed within a rough opening of a building. The Door functions to manually open, and then automatically close. Both the Sidelite and Slide door have a full breakout feature. This manual offers step by step instructions.

CAUTION

A pedestrian Door that does not have its glass sections installed at the Factory shall specify that the glazing material employed is to comply with the requirement in UL 325 par.30.5.1:

“The glazing material in both fixed and sliding panels of all sliding doors and in all unframed swinging doors shall comply with the requirements in the Performance Specifications and Methods of Test for Safety Glazing Material Used in Buildings, ANSI Z97.1. Glazing material for other pedestrian doors shall also comply with ANSI Z97.1, except that single strength or heavier glass may be used for those portions of doors involving a glazed area of less than 1ft² (0.9 m²) and having no dimension greater than 18 in (457 mm)”.

CHAPTER 4: GETTING STARTED

SECTION 4.1: Type of Unit

- ▶ Mechanical Configuration:
 - Self Closing Slide Door: Automatically closes after being manually opened.
 - Hold Open capability that requires power to Header.
- ▶ Emergency Egress: Both the Slide door and Sidelite breakout for emergency egress.
- ▶ Maximum Door Weight Limit: 135 pounds

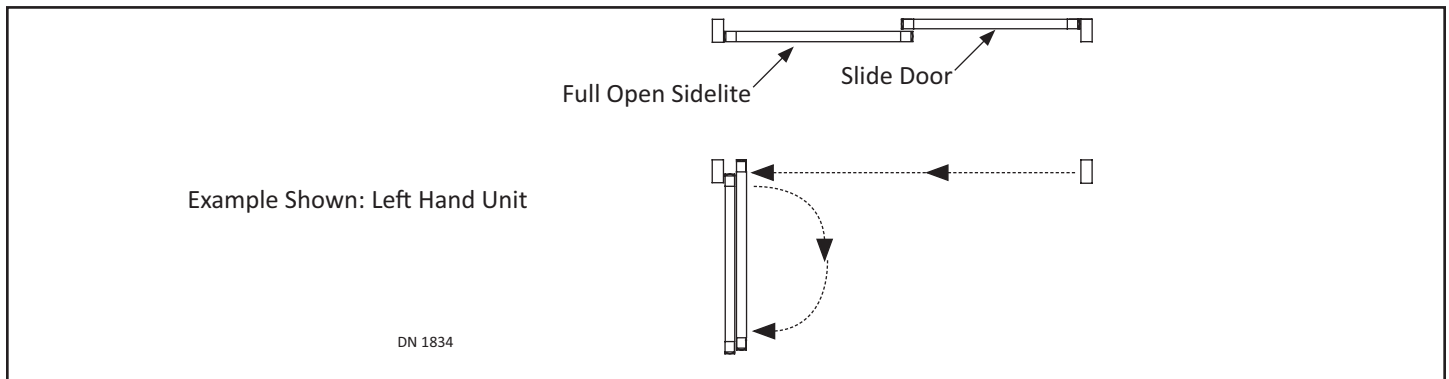

SECTION 4.2: Power Requirements (for Hold Open Option):

- ▶ 24VDC, 250mA minimum, UL Listed class 2 power supply.
- ▶ May use: Power Supply 24 VDC, 0.5A; NABCO P/N V-00022.

SECTION 4.3: Inspect the Rough Opening

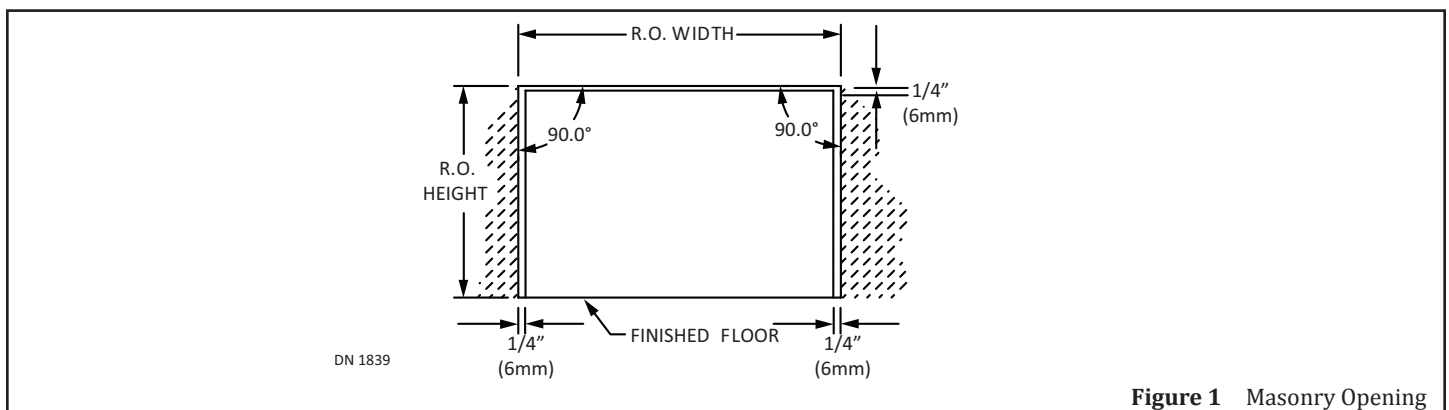

Figure 1 Masonry Opening

1. Ensure the Rough Opening is correct size.
 - ▶ The width of the Rough Opening should equal: **PACKAGE WIDTH + 1/4 INCH ON EACH SIDE**
 - ▶ The height of the Rough Opening should equal: **PACKAGE HEIGHT + 1/4 INCH**

Note: Make allowances for tile or other existing materials that may change the floor height.

CHAPTER 5: ASSEMBLE DOOR FRAME

1. Place the Header on a flat surface with the removable cover facing up. Protect Header from scratches.
2. Position Jamb tubes on either side of Header according to the instruction sticker located on each Jamb tube that shows proper location and orientation.
3. Position Header so the Removable Cover faces the Non-Breakout side of the opening.

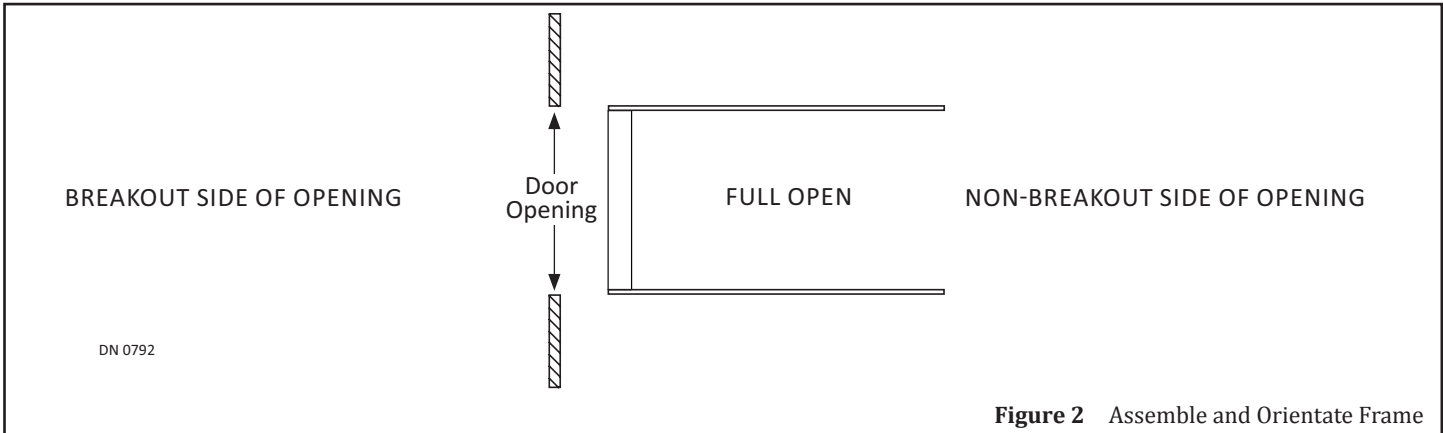

Figure 2 Assemble and Orientate Frame

4. Go to the bottom of Header, remove (2) #8-32 x 5/8" Phillips Head screws used to secure the Removable Cover.
5. Remove the Cover by lifting it up and then pulling it out.

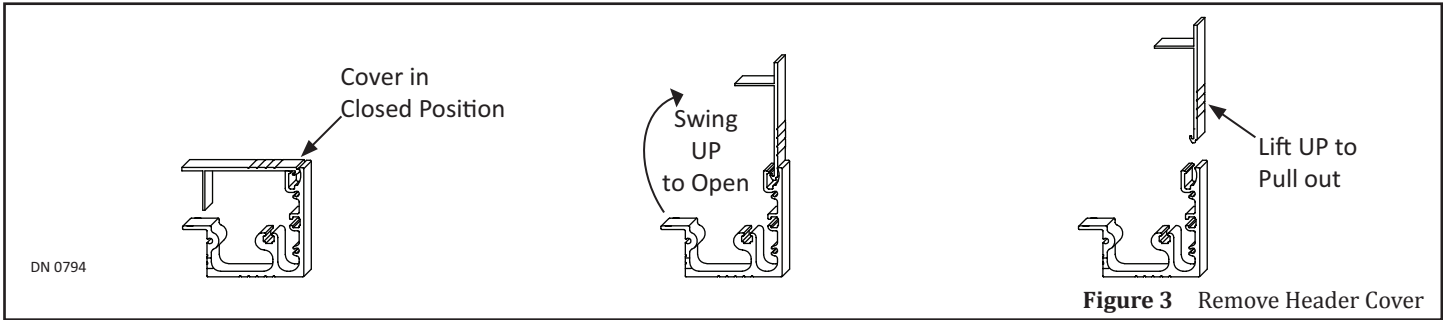

Figure 3 Remove Header Cover

6. Secure Header to Jamb Tubes with (3) 1/4-20 x 3/4 inch Self Tapping Screws.
 - a. Jamb Tubes are Non-Handed and pre-drilled with (4) screw holes.

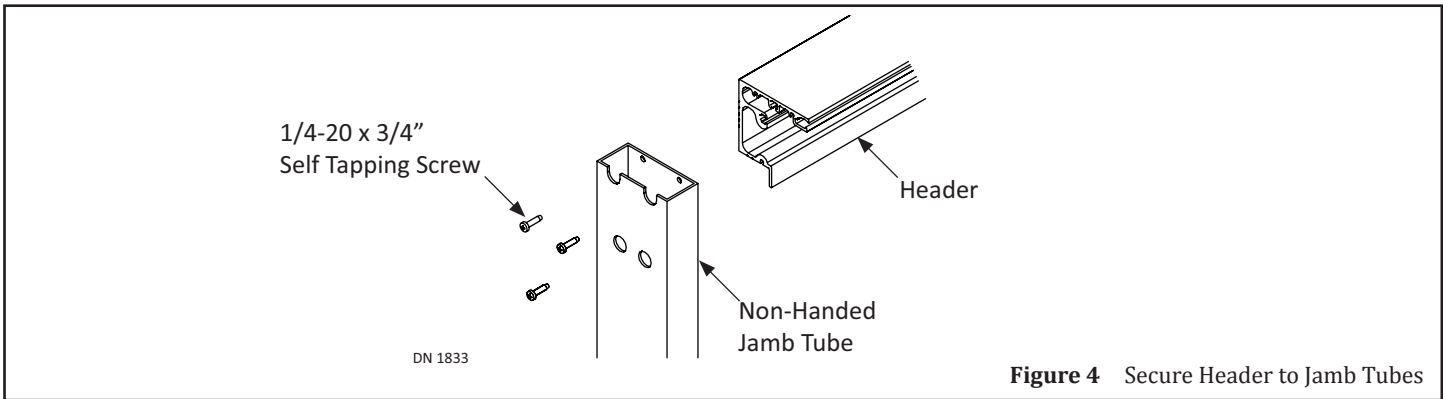

Figure 4 Secure Header to Jamb Tubes

CHAPTER 6: SECURE DOOR FRAME TO BUILDING

SECTION 6.1: Prepare Door Frame

7. Shim and Plumb Jamb Tubes in both planes to ensure the rough opening allows a 1/4 inch clearance.
8. Shim and plumb the Transom Horizontal at the top to ensure the rough opening allows a 1/4 inch clearance.

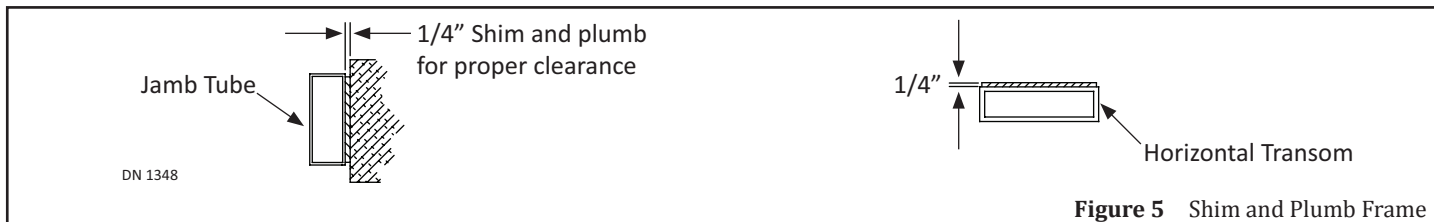

Figure 5 Shim and Plumb Frame

SECTION 6.2: Secure Door Frame to Building

- ▶ Anchors are not provided by NABCO.
- ▶ Anchors must be appropriate for the type of structure being fastened to.
- ▶ Screw in anchors to secure the Frame (per manufacturer's specifications).
- ▶ Ensure anchor heads do not come in contact with edges of glass to prevent breakage.
- ▶ Do not overtighten anchors to prevent deforming Jamb Tubes.

Note: It is recommended to countersink holes as required to flush the surface.

Note: It is recommended to drill tap threads for 1/4 inch anchors in a steel or aluminum structure.

Note: Do not overtighten anchors to prevent deforming Jamb Tubes.

6.2.1 Anchor Placement for Header

Use 1/4 inch diameter anchors, with a maximum 48 inches on center. First anchor maximum is 36 inches from each end of the Header. Anchors and Fasteners must be appropriate for the type of structure being fastened into. Anchors and Fasteners are not provided by NABCO.

6.2.2 Anchor Placement for Jamb Tube

Use 1/4 inch diameter anchors with a minimum of 3 per Jamb tube, maximum is 48 inches on center. Drill 1/4 inch diameter holes in the face of Jamb and then countersink each hole. Anchors and Fasteners must be appropriate for the type of structure being fastened into. Anchors and Fasteners are not provided by NABCO.

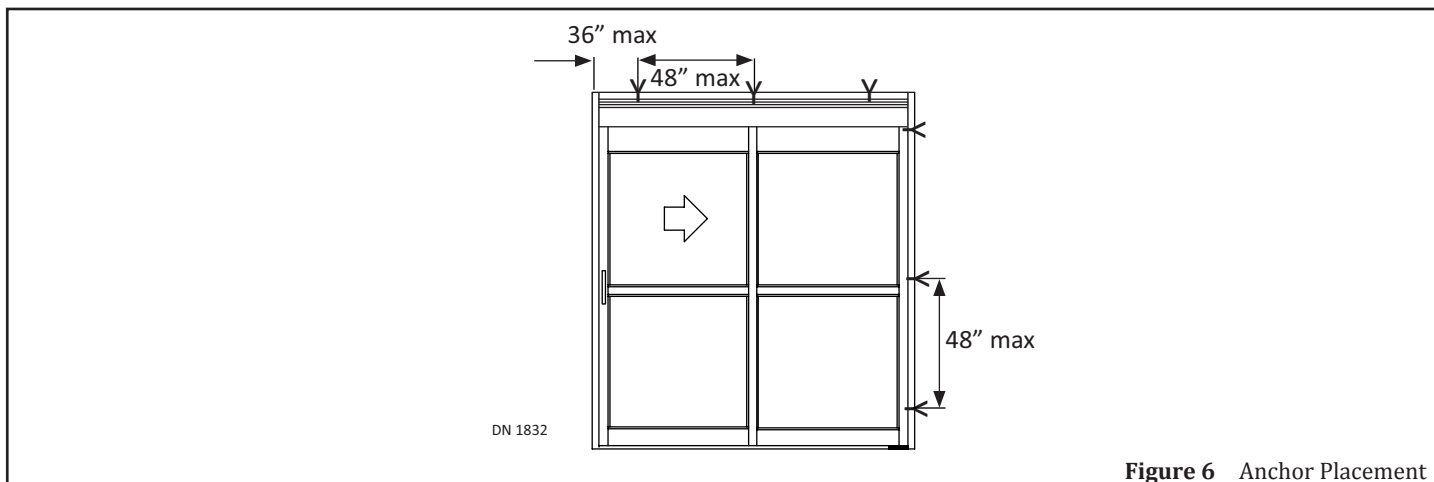
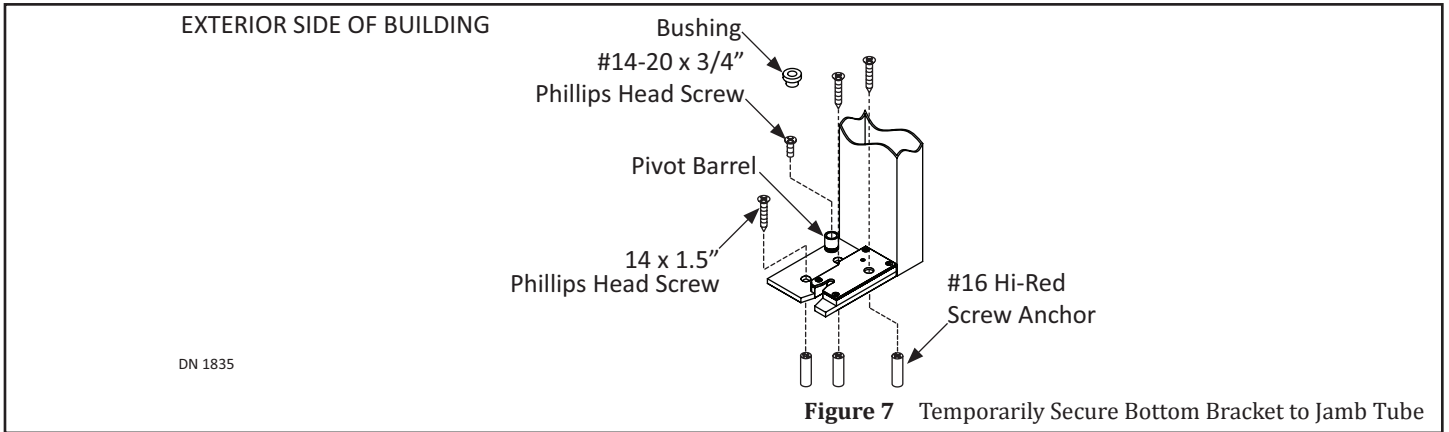

Figure 6 Anchor Placement

CHAPTER 7: INSTALL THE FULL OPEN SIDELITE

SECTION 7.1: Install the Bottom Pivot

1. With the Center and butt the Bottom Pivot Assembly up against the Pivot Jamb Tube.
 - a. Ensure the Bottom Pivot Barrel is on the Exterior side of Building.
2. Use the Bottom Pivot as a template. Mark and drill (3) 1/4 inch screw holes into the floor at least 1-1/2 inches deep.
3. Insert (1) #16 Hi-Red Anchor into each drilled hole.
4. Secure the Bottom Pivot to Floor with (3) #14 x 1-1/2 inch Phillips Head Screws. Cap the Bottom Pivot Barrel with (1) Bushing.



SECTION 7.2: Insert Pivot Pins into Pivots

1. Go to the Pivot Pin located inside the Pivot Stile, at the bottom. Carefully insert the Pivot Pin inside Bottom Pivot Bushing.

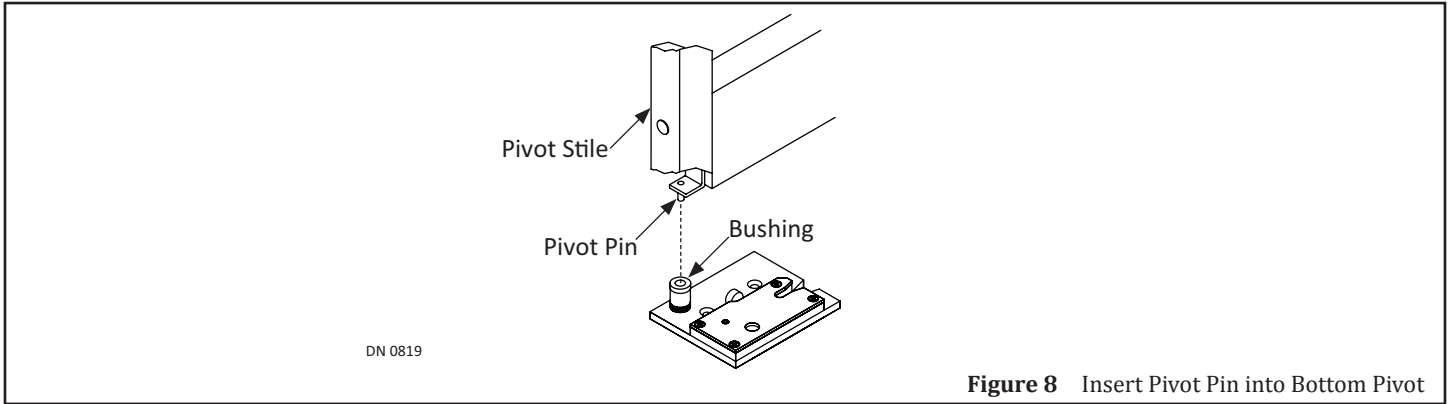

2. Align the Retracting Pivot Pin to the Pivot Pin hole located at the bottom of Header. Push the Retracting Pivot Pin down, and then let go so the Pin can snap into the Pivot Hole.
 - a. Ensure the Retracting Pivot Pin fully engages the hole. If necessary, lift up on the Retracting Pivot Pin with a screwdriver.

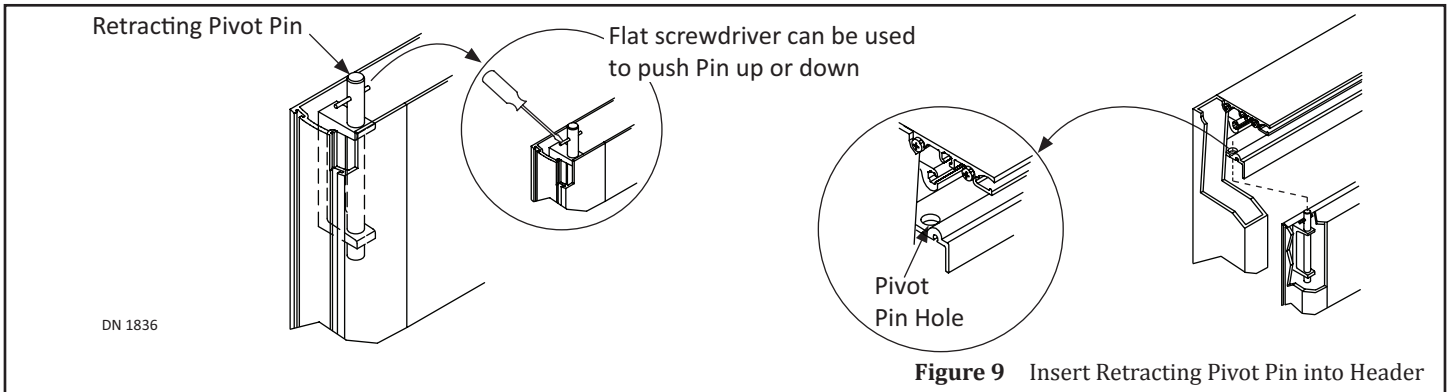

SECTION 7.3: Adjust Door Height

1. Remove the Sidelite Panel.
2. Go to the Bottom Pivot. Remove (1) Bushing, (1) 1/4-20 x 3/4 inch Phillips Head Screw, and the Bottom Pivot Barrel.
3. To adjust the Door Height, add or subtract 1-3 Washers from underneath the Bottom Pivot Barrel.
4. Reinstall hardware and Sidelite Panel.

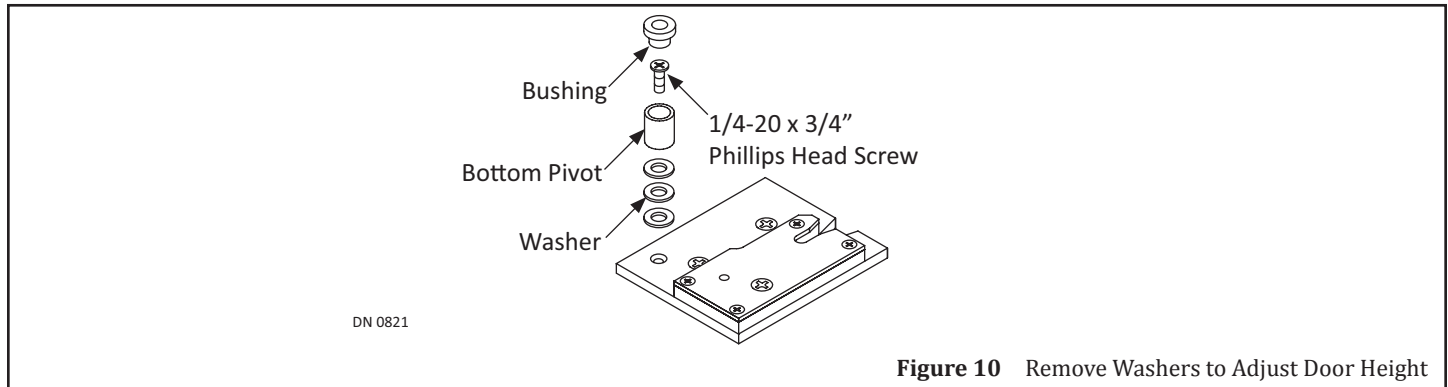

SECTION 7.4: Prepare the Header for the Flush Bolt

1. Open the Sidelite 10 - 15 degrees.
2. Go to the Strike side of Sidelite Panel. Locate and then raise the Flush Bolt so it extends past the top of door.
3. Close the Sidelite Panel until the Flush Bolt butts up against the face of Header. Locate and mark the center of the Flush Bolt.

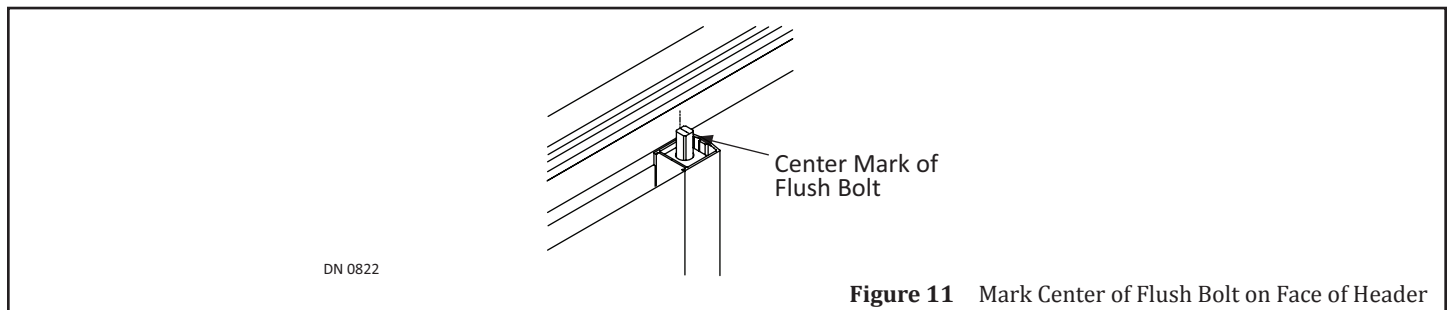

4. Open the Sidelite Panel.
5. Extend the marked line down to the bottom, and then under the Header until the second groove, closest to the Face of Header Lip, is reached (Flush Bolt Groove).
6. Drill a 3/764 inch hole into the center of the Flush Bolt Groove.

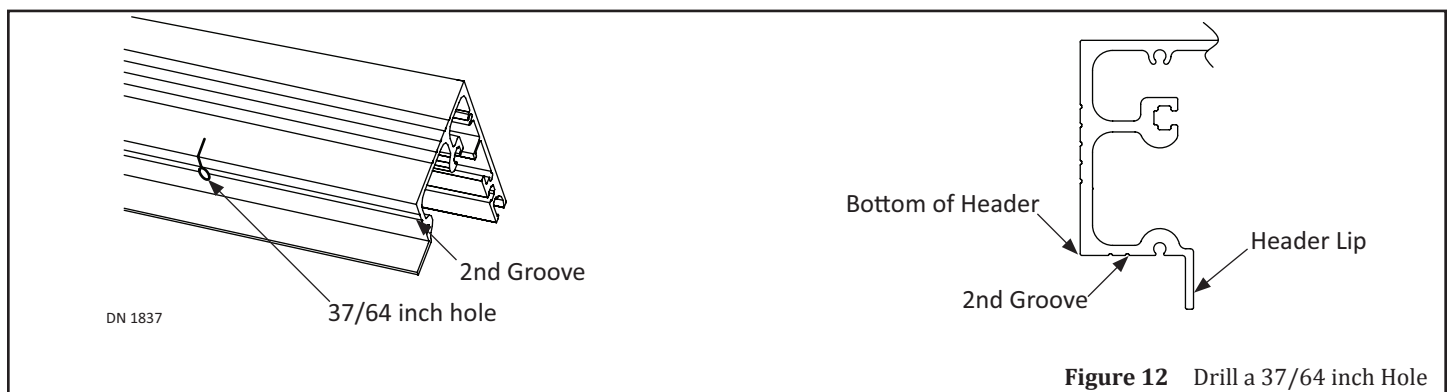

7. Lower the Bolt. Fully close the Sidelite Panel.
8. Raise the Bolt to ensure it properly fits inside the drilled Hole.

SECTION 7.5: Install the Bottom Guide

1. Obtain (1) Bottom Guide, (2) 1/4" Star Washers, and (2) 1/4 - 20 x 3/4 inch Hex Head Cap screws.
2. Go to the Strike Stile on Sidelite Panel. Locate (2) pre-drilled screw holes at the bottom.
3. Slide (1) 1/4 inch Star Washer onto each 1/4 - 20 x 3/4 inch Hex Head Cap screw.
4. Position the Bottom Guide so it is flush with the bottom of the Sidelite.
5. With a 7/16 inch Box End Wrench, secure the Bottom Guide to the Sidelite Panel with 1/4 - 20 x 3/4 inch Hex Head Cap screws.

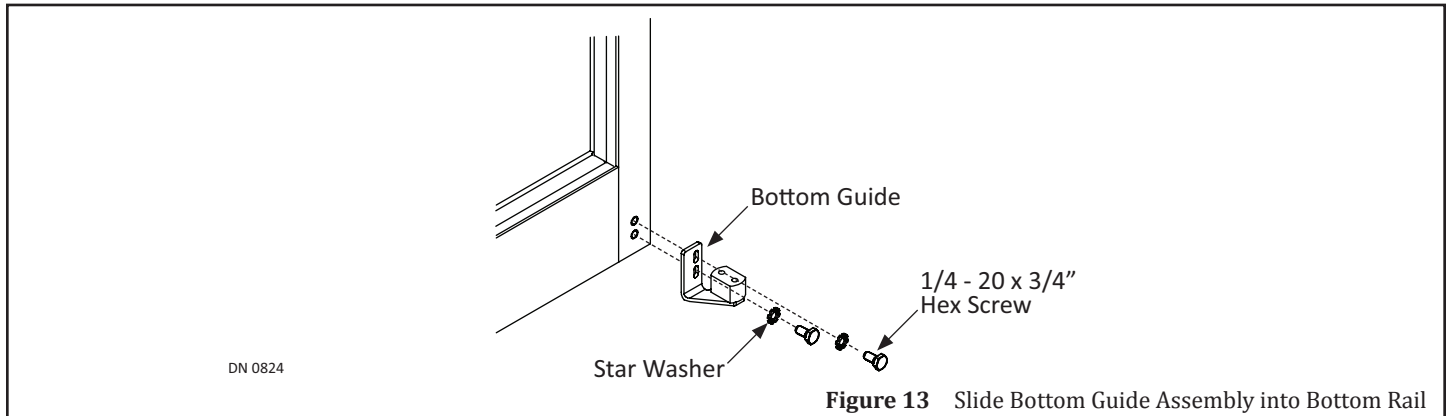

Figure 13 Slide Bottom Guide Assembly into Bottom Rail

CHAPTER 8: INSTALL THE SLIDE DOOR

Note: Header Layout is reverse for Slide doors that open to the left.

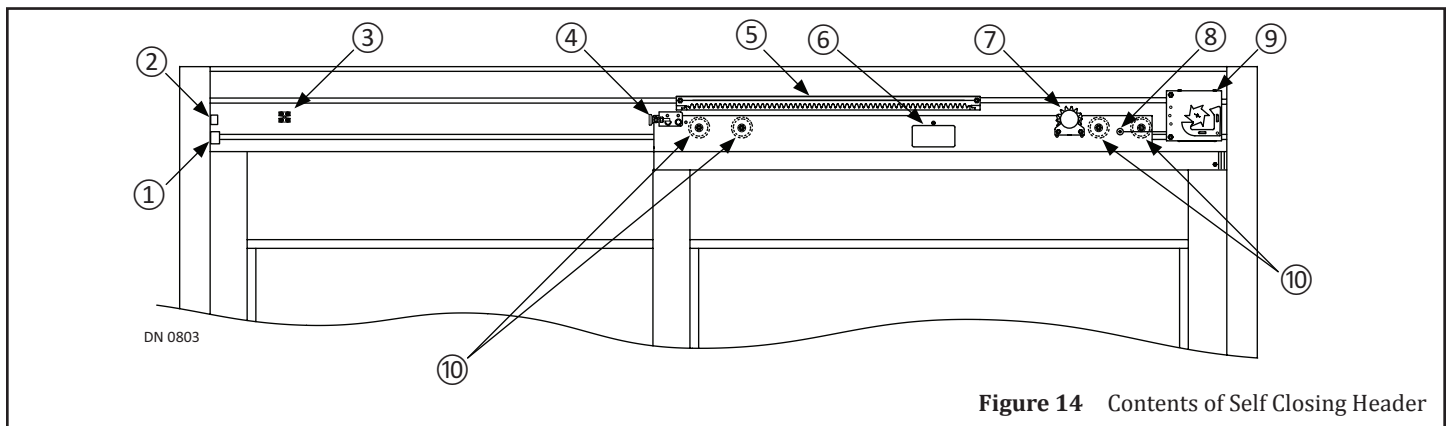

Figure 14 Contents of Self Closing Header

- | | |
|---------------------------------------|----------------------|
| 1. Door Stop | 6. Instruction Label |
| 2. Electromagnet* | 7. Rotary Damper |
| 3. Terminal Strip for 24 VDC | 8. Shoulder Bolt |
| 4. Hold Open Bracket w/Leveler Mount* | 9. Pull Spring |
| 5. Control Rack | 10. Hanger Roller |

SECTION 8.1: Wire the Rocker Switch and Electromagnet

DANGER

Shut the installation site, branch Circuit Breaker OFF. Failure to do so may result in serious personal or fatal injury. Always verify the power supply is disconnected, with a voltmeter.

WARNING

All high voltage electrical connections must be made by licensed electricians according to National and Local electrical codes/regulations.

CAUTION

Ensure that the Grounding of the Electric Power Supply is installed/connected in a proper way (especially the PE Cable from the Building Side).

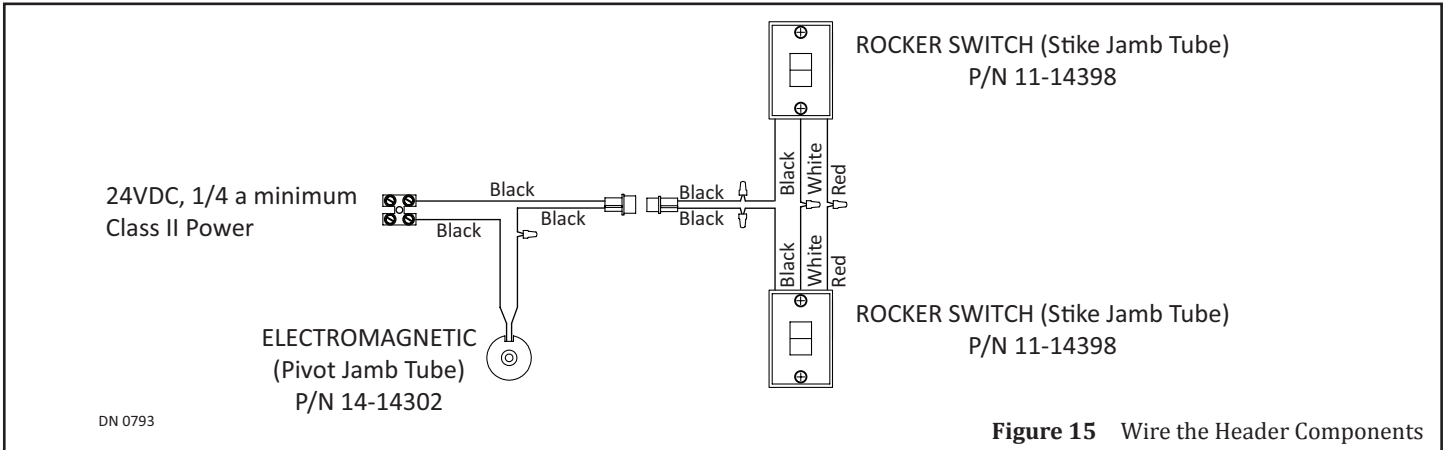

Figure 15 Wire the Header Components

SECTION 8.2: Lift Carrier onto Track

Attention: It is the responsibility of the Installer to reverse Hanger Roller location before installing the Slide Door.

1. Cover the Trail door with cardboard on the side that will face the Lead door.
2. Go to the front side of Carrier located on Top Rail of Slide door.
3. Remove each Hanger Roller by loosening the nut with a 1/2" open end Wrench.
4. Go to the back side of Carrier. Reinstall each Hanger Roller by partially tightening each nut with a 1/2" open end Wrench.
 - a. Hanger Rollers must be loose for the Slide door to 'catch' onto the Track properly.
 - b. For detailed instruction, please refer to the Label located on the Face of Carrier.

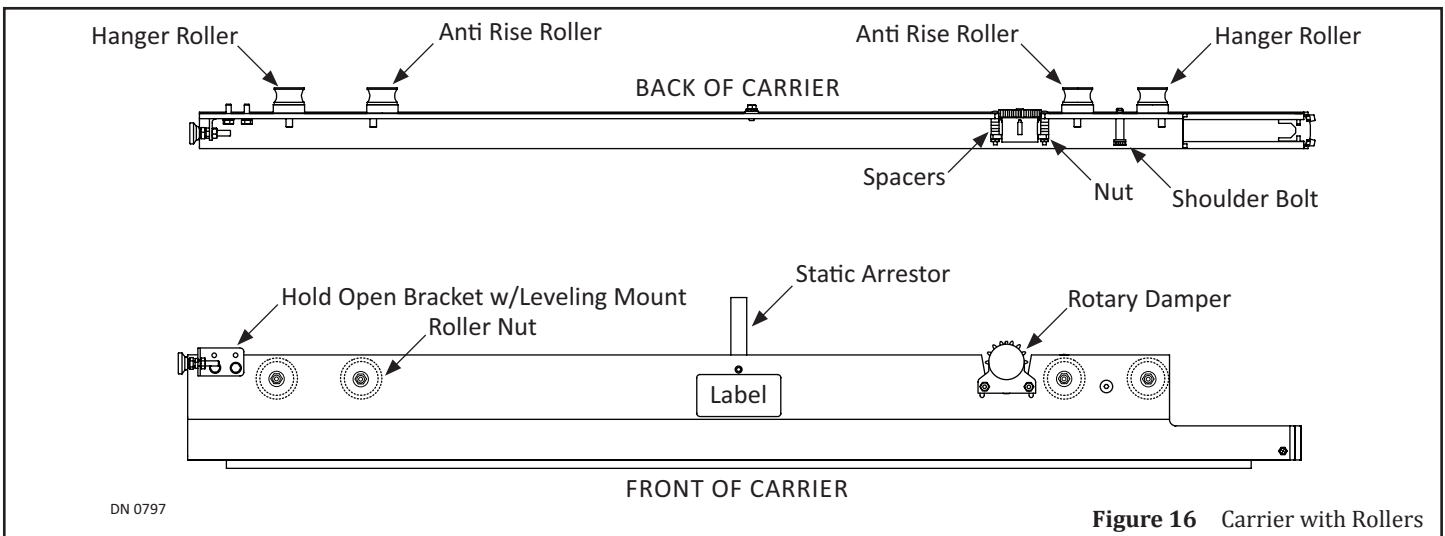

Figure 16 Carrier with Rollers

5. Go to the Rotary Damper. Loosen 2) #10 hex nuts with a 3/8 inch wrench, until the Rotary Damper slides down the slots.
6. With Slide door tilted install the Carrier onto the Track.
 - a. Slide door is slightly tilted to make it easier for the (4) Rollers to 'catch' onto the track.

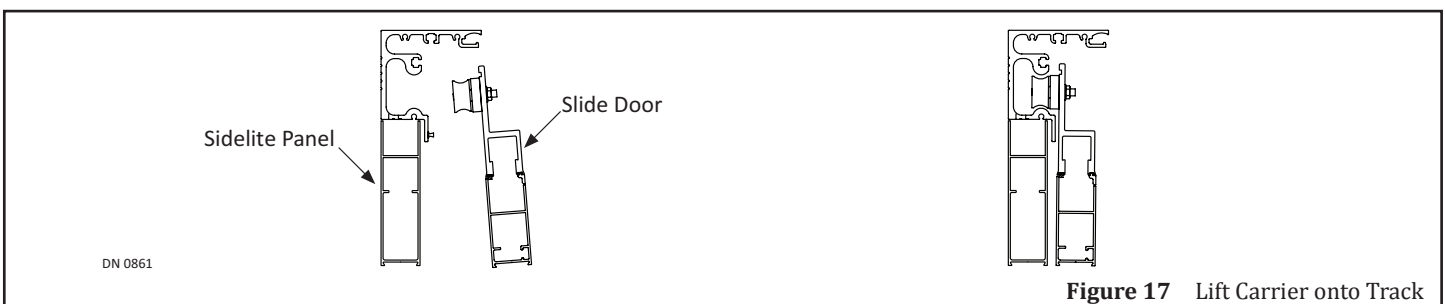
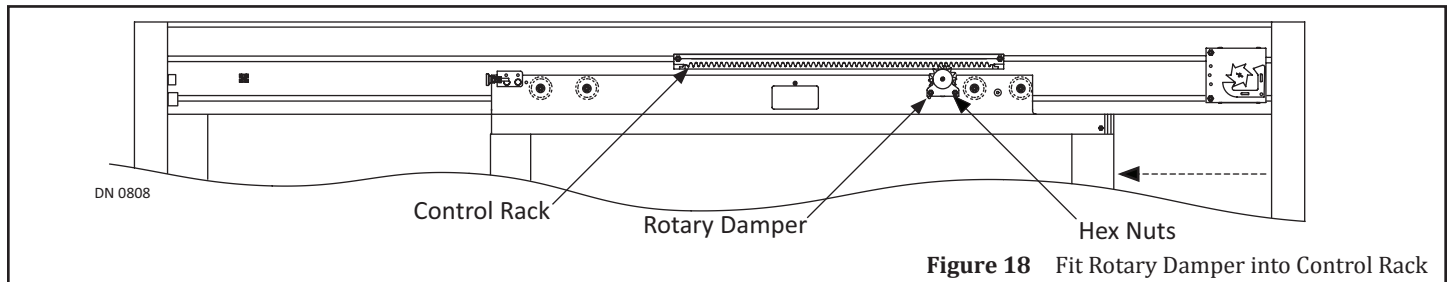

Figure 17 Lift Carrier onto Track

SECTION 8.3: Align the Rotary Damper to the Control Rack

1. Manually open the Slide door until the Rotary Damper is directly underneath the Control Rack.
2. Go to the Rotary Damper. If not already loosened; loosen (2) #10 hex nuts with a 3/8 inch wrench.
3. Slide the Rotary Damper up the slot until the teeth can fit inside the Control Rack teeth.
4. Tighten (2) #10 Hex nuts that were just loosened to secure the Rotary Damper in place. To ensure proper engagement between Rotary Damper and Control Rack, slide the door back and forth to check for binding or chatter.



SECTION 8.4: Attach the Pull Spring to the Carrier

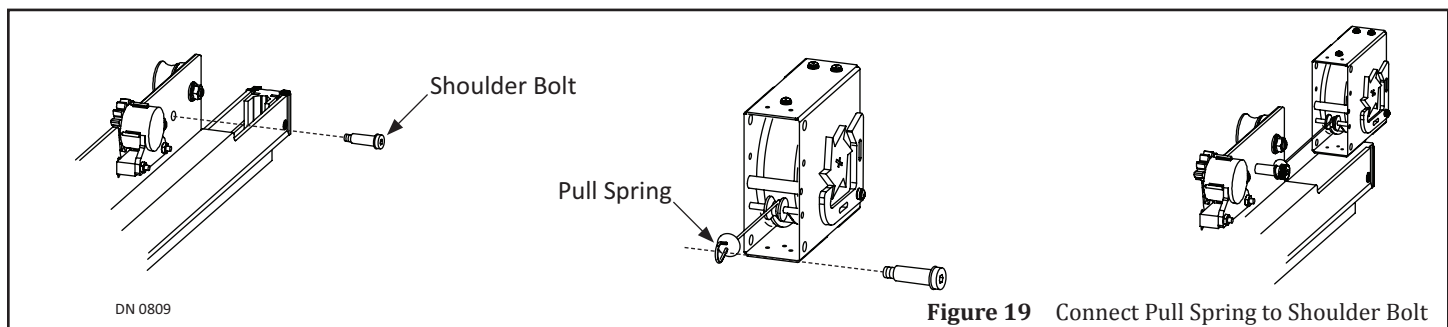

1. Fully close the Slide door. Go to the Shoulder Bolt located between (2) Hanger Rollers closest to the Strike Jamb.
2. Remove the Shoulder Bolt with a 3/16 inch Allen Wrench. Attach the Pull Spring to the Shoulder Bolt.
3. Reinstall the Shoulder Bolt with the Pull Spring attached.

SECTION 8.5: Align Slide Door with Electromagnet and Door Stop Bumper

1. Fully Open the Slide door. Check alignment between the:
 - ▶ Carrier and Door Stop.
 - ▶ Electromagnet and Hold Open Bracket Assembly.
 - a. Both pairs should come in contact at the same time.

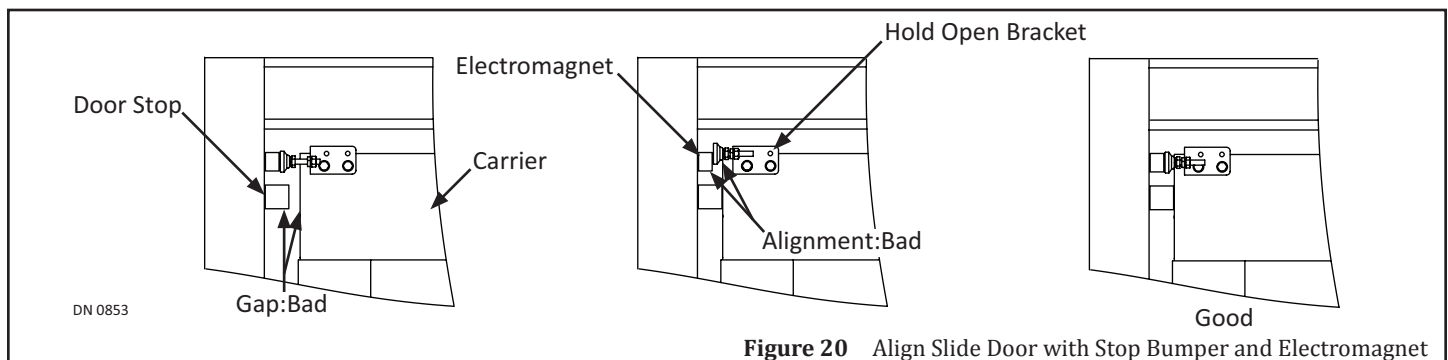

8.5.1 Adjust Gap between Carrier and Door Stop

1. Go to the Hold Open Bracket Assembly. Loosen (2) 1/4-20 Hex Nuts.
2. Fully open the Slide Door until the Carrier butts against the Door Stop. Tighten (2) 1/4-20 Hex Nuts.

8.5.2 Adjust Gap between Carrier and Door Stop

1. Go to the Hold Open Bracket Assembly. Loosen (2) 1/4-20 Hex Nuts.
2. Raise the Bolt up or down until the Level Mount is properly aligned with the Electromagnet. Tighten 1/4-20 Hex Nuts.
 - a. If the Hold Open Bracket needs to be raised/lowered more:
 1. Go to the Hold Open Bracket (Back Plate). Remove (2) 1/4-20x0.750" Hex Head screws and (2) Star Washers.
 2. Raise or lower the Hold Open Bracket until the Level Mount is properly aligned with the Electromagnet.
 3. Tighten the (2) 1/4-20x0.750" Hex Head screws and (2) Star Washers.

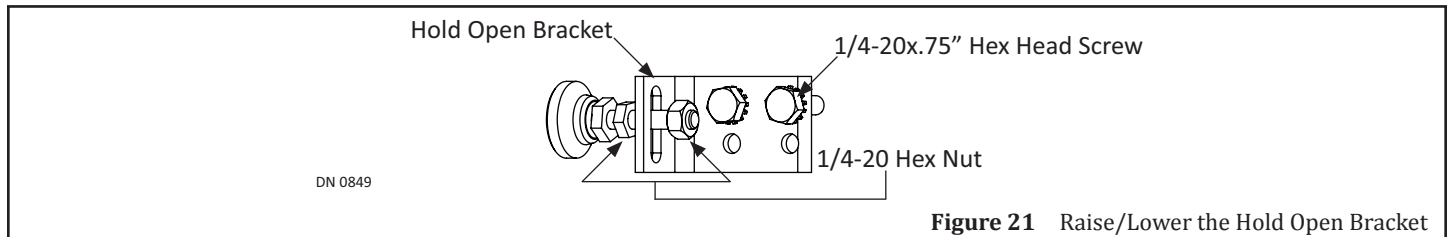

Figure 21 Raise/Lower the Hold Open Bracket

SECTION 8.6: Adjust the Closing Speed

CAUTION Do Not let Slide door slam shut.

1. Fully open the Slide door. Allow Slide door to fully close. It should close slowly.
 - a. If the Slide door does not close fully:
 1. Go to the Pull Spring. With a Flathead screwdriver turn the Tension plate counterclockwise to increase tension.

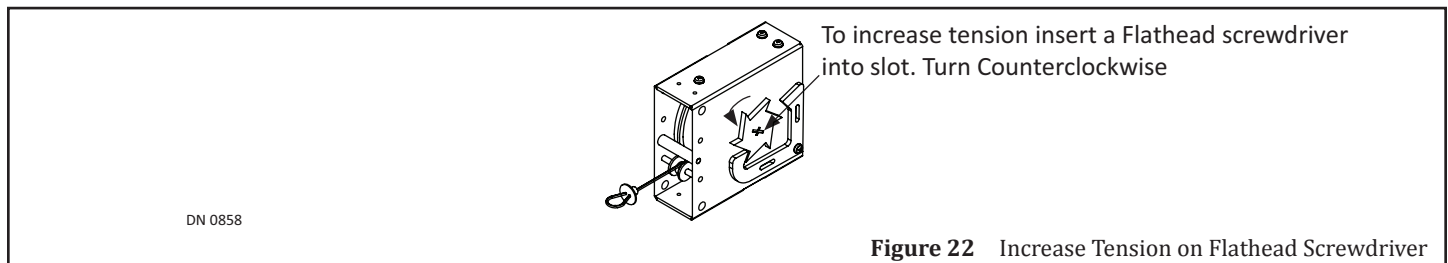

Figure 22 Increase Tension on Flathead Screwdriver

- b. If the Slide door closes too fast:
 1. Go to the Pull Spring. With both Index fingers carefully push the Tension Bracket forward so the Tension Plate clicks clockwise.
 - a. This will decrease tension on the Pull Spring.
 2. With both thumbs push the Tension Bracket back to starting position.
 - a. Do not pinch fingers while setting the Tension.

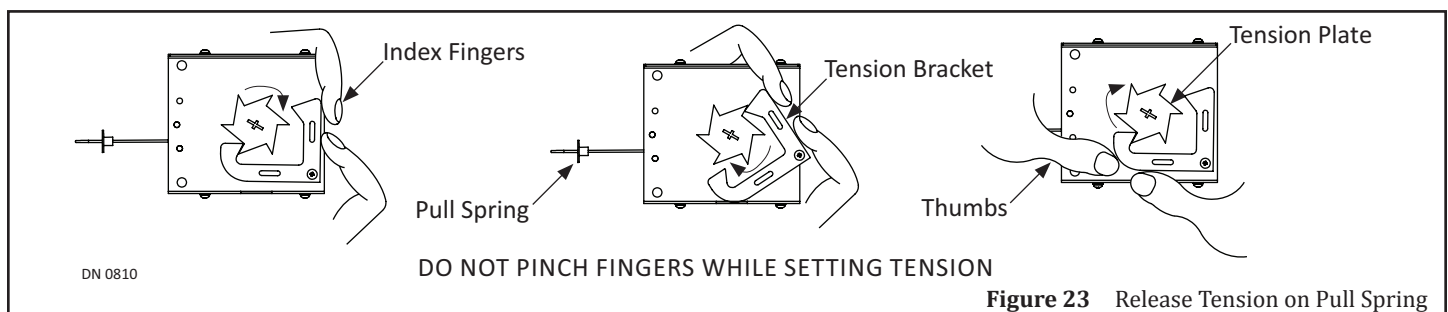

Figure 23 Release Tension on Pull Spring

- c. For more speed control, adjust the Rotary Damper.
 1. Turn the dial clockwise to increase damping.
 2. Turn the dial counterclockwise to decrease damping.

SECTION 8.7: Fine Tune the Latching Speed

- ▶ To increase Latching speed:
 1. Move the Control Rack farther away from the Strike Jamb Tube.
 2. Adjust the Pull Spring and Rotary Damper after moving the control rack.
- ▶ To decrease Latching speed:
 1. Move the control rack closer to the Strike Jamb Tube. Slide door will move faster before hitting the Control Rack.
 2. Adjust the Pull Spring and Rotary Damper after moving the Control Rack.

SECTION 8.8: Adjust Height on Slide Door

CAUTION

Do Not rotate the stud counter-clockwise. Doing so will unthread the Axle from the Hanger Roller.

1. Measure the gap between the door and the floor. The gap must be between 3/16" to 7/16" (3/8" nominal).
2. Loosen each Hanger Roller Nut. It is recommended to adjust the (2) Hanger Rollers located at each end of door first.
3. Turn each axle clockwise to raise or lower the Sliding door. Retighten each Hanger Roller nut. Do not overtighten.
4. Loosen each Anti-Rise Roller nut. Turn each axle clockwise until each Anti-Rise Roller almost makes contact with the top of Roller Track. Gap should be about the same thickness of a credit card. Retighten each Anti-Rise Roller nut.

CHAPTER 9: INSTALL WEATHERING



Figure 24 Weathering Placement

1. Install Brush by sliding it into the Brush Holder.
2. Secure the Brush Holder against the Bottom Rail of Swing Sidelite with (3) #6 x 1/2 inch self tapping screws.
 - a. It is recommended to leave at least a 1/8 inch gap between the Edge of the Pivot Stile and the Brush Holder, while allowing 1/8 inch Vinyl to extend past the Brush Holder so the gap is filled.
3. Breakout the Swing Sidelite.
4. Secure the Brush Holder against the Bottom Rail of Slide door with (3) #6 x 1/2 inch self tapping screws.

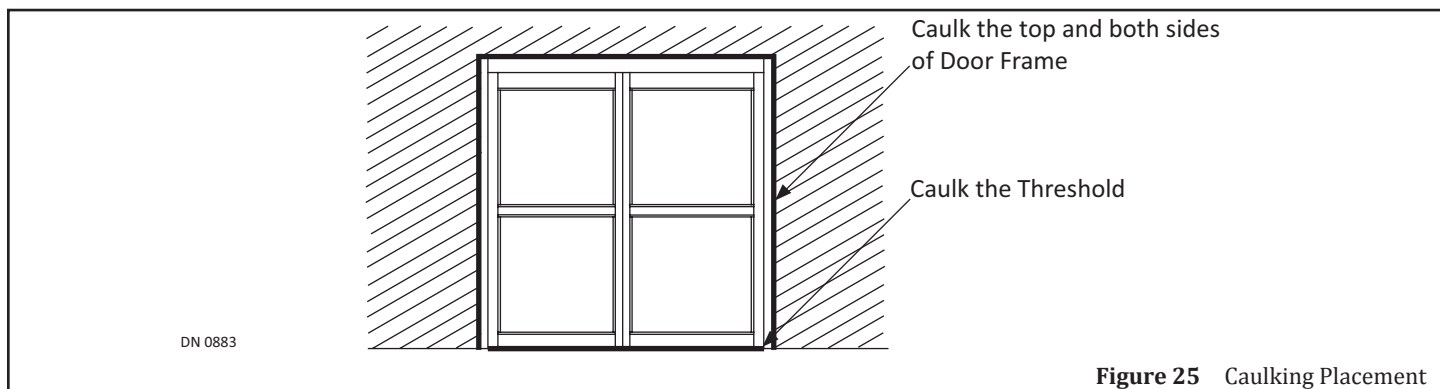

Figure 25 Caulking Placement

5. Ensure the entire Door Frame is properly secured to the Rough Opening.
6. Apply caulking bead between the Door Frame and Rough Opening (inside and outside).
7. Apply caulking bead to the Threshold at the bottom of Door Frame.

CHAPTER 10: INSTALL THE GLASS STOPS

WARNING

Glazer must be fully trained and qualified. Failure to do so may result in bodily injury, or property damage.

Note: Ensure the installation area is free of debris and/or sharp objects. Failure to do so may damage the glass or contaminate the glazing process.

SECTION 10.1: Glass Stops for Door Panels

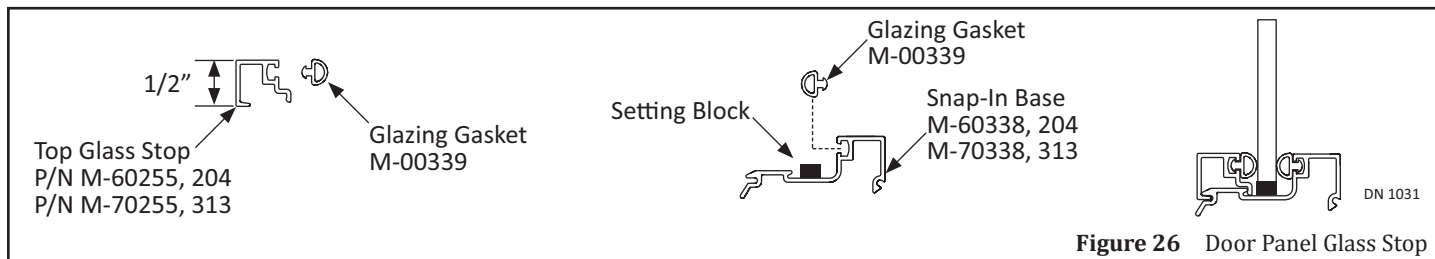

Figure 26 Door Panel Glass Stop

Note: The Snap Base and Vinyl Seals/Gaskets are preinstalled at the NABCO Factory.

1. Ensure the Snap Base is free of debris and/or sharp objects.
2. Install the Setting Blocks (not provided by NABCO) and Glass Panel.
3. Snap the Glass Stop into the Snap Base.

CHAPTER 11: GLAZING (HEAVY/WIDE DOORS)

Attention: Installation of all Glass must comply with ANSI Standard Z97.1

In accordance with standard glazing practices, Nabco recommends Cross-Blocking for maintaining square with heavy glass or wide Door Panels (Fixed and Full Open). Cross-Blocking helps direct glass weight away from the strike edge of the door, to prevent sagging and possibly dragging on the floor or threshold.

If the Door Panel is not square and sags at the lead edge, increase the thickness of the Glazing Block (not provided by NABCO). Increasing the thickness of the Glazing Block, raises the Door Panel.

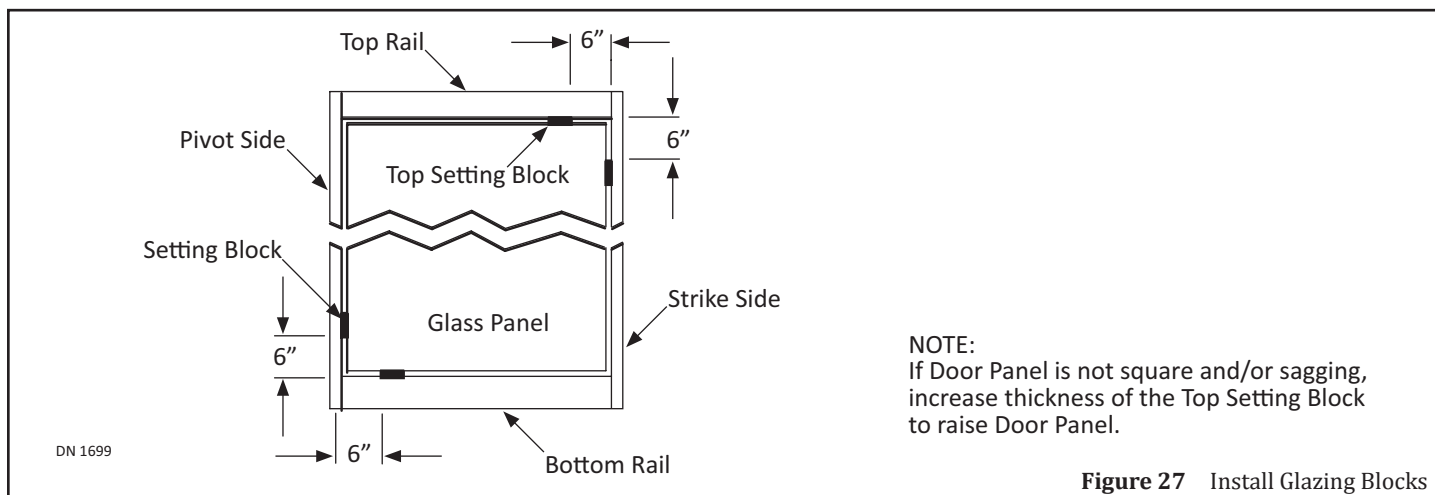

Figure 27 Install Glazing Blocks

Note: Only place Glazing Blocks in the designated marked spots.

1. Go to the STRIKE side of door panel at the TOP.
 1. Measure (6) inches from the Bottom edge of Top Rail, towards the Pivot side of Door Panel. Mark that spot.
 2. Measure (6) inches from the Top Corner of the Strike Edge down to the bottom of the Door Panel. Mark that spot.
2. Go to the PIVOT side of door panel at the BOTTOM.
 1. Measure (6) inches from the Top edge of Bottom Rail, up to the top of Door Panel. Mark that spot.
 2. Measure (6) inches from the Center of Pivot, towards the Strike side of Door Panel. Mark that spot.

3. Place (1) Glazing Block (not provided by NABCO) between the Glass and Door Frame, at marked spots.
 - a. It may be necessary to use more than (1) Glazing Block.

CHAPTER 12: ADJUSTMENTS

SECTION 12.1: Adjust Height on Slide Door

Hanger Rollers adjust the height of a Slide door, and to ensure the Leading edge of Trail door and Sidelite Panel are parallel at the top or bottom. The recommended gap between the Bottom Rail and the floor is 5/8 inch.

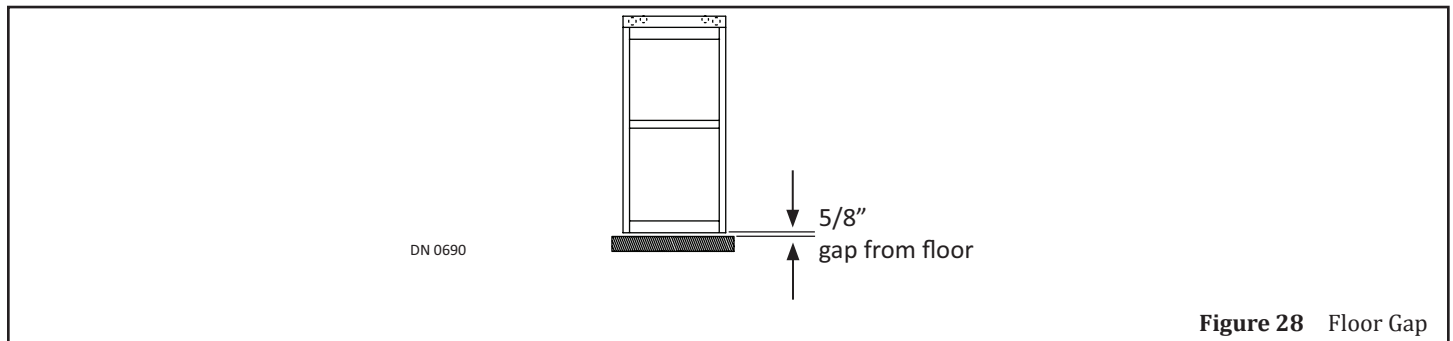

Figure 28 Floor Gap

CAUTION

Do not rotate the Roller Axle counter-clockwise. Doing so will unthread Axle from Roller Assembly.

1. Go to the Carrier on top of Slide Door. Loosen (4) Hanger Rollers by inserting (1) 7/32" Allen wrench into the exposed end of a Roller Axle. Hold the 7/32 inch Allen wrench in place to keep the Roller Axle stationary. At the same time, loosen (1) 7/16-20 Whiz Lock nut with a 15/16 inch Open End Wrench.

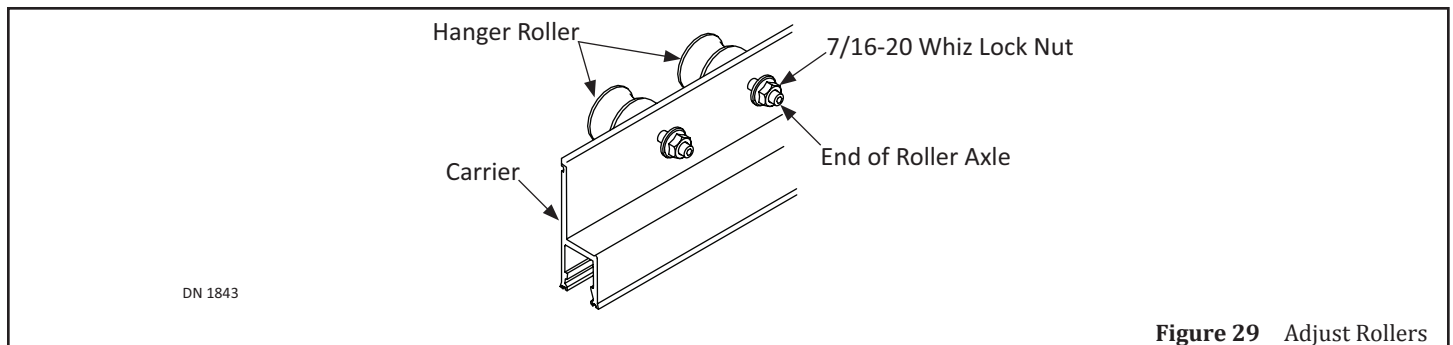
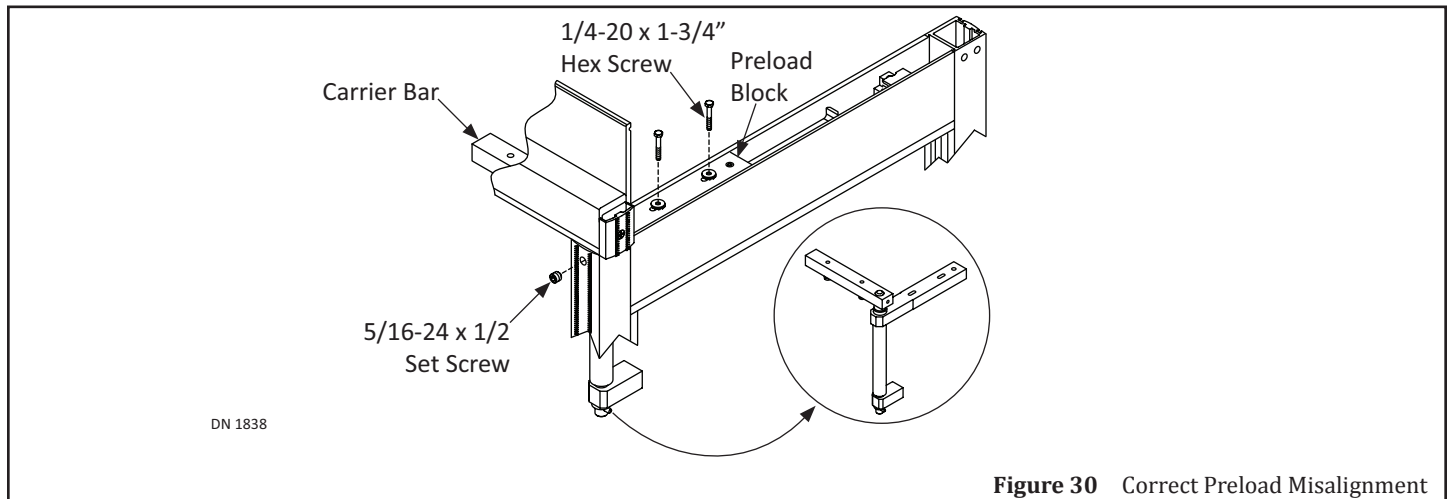

Figure 29 Adjust Rollers

2. Keep the Roller Axle stationary by clamping the 7/32 inch Allen wrench onto the exposed end of the Roller Axle.
3. Rotate the 7/16-20 Whiz Lock nut on each Hanger Roller to lower or raise the Slide Door.
4. Ensure the Leading Edge of the Slide door and Header are parallel.
5. With the 7/32 inch Allen wrench still in place, tighten each (1) 7/16-20 Whiz Lock nut with a 15/16 inch Open End Wrench.

SECTION 12.2: Correct Preload Misalignment

1. Breakout the Slide Door. Loosen the 5/16-24 x 1/2 Set Screw located on Pivot Stile, at the Top.
2. Go inside the Top Rail. Loosen (2) 1/4-20 x 1-3/4 inch Hex Screws used to secure the Preload Block to the Top Rail.
3. Slide the Pivot Carrier back or forth until the Slide Door and Carrier are properly aligned.
4. Fully close the Slide Door to ensure the Preload is aligned. Retighten the Hex Screws.



SECTION 12.3: Adjust the Nose Caster

Note: Installed on Units that are 54 Inches Wide (or greater) and/or over 200 Pounds.

1. Go to the Bottom Rail. Remove (1) End Cap.
2. Breakout the Slide door. Locate the Nose Caster that was pre-installed within the Strike.

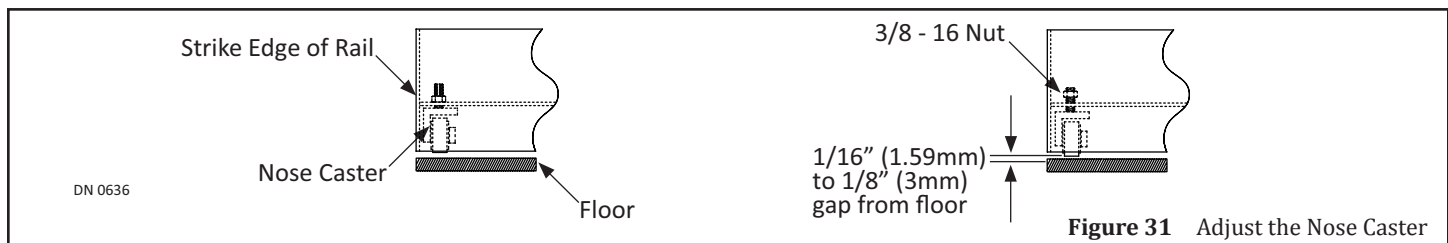

3. Loosen the #8-32 Set Screw. Position the Wheel so it is perpendicular to the Bottom Rail. Retighten the #8-32 Set Screw.
4. Fully close the Slide door. Ensure the Nose Caster does not hit or scrape the floor. Reinstall the End Cap. Correct Preload Misalignment.

SERVICE PARTS: KIT

NARROW: RH P/N A-00614; LH P/N A-00615, Bi-Fold A-00616

MEDIUM: RH P/N A-00669; LH P/N A-00669, Bi-Fold A-00670

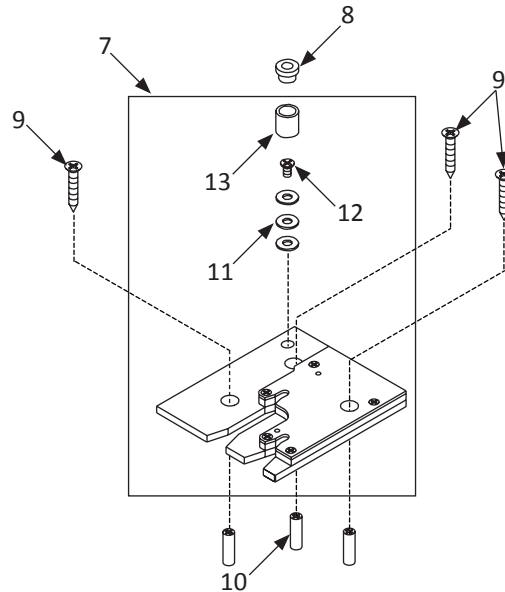
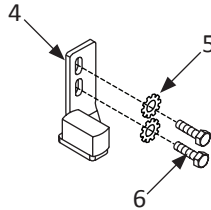
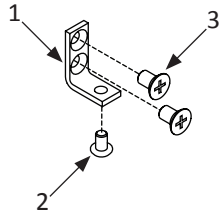

DN 1856

Service Parts Kit

Item	Part	Note	Description	QTY	Used To
------	------	------	-------------	-----	---------

1	M-01049		CLIP, COVER	2	Secure Cover to Header and Jamb Tube
2	T-00323		RHMS,8-32x0.250L.,PHIL,ZINC	2	Secure Cover to Header
3	T-00016		FHMS,1/4-20x0.438L.,PHIL,UNDERCUT,ZINC	4	Secure Cover to Jamb Tube
4	A-00318	LH,NAR	GUIDE BLOCK, NAR STILE, LH	2	Guide Slide Door back/forth, keep Rollers in Track
	A-00321	RH,NAR	GUIDE BLOCK, NARR STILE, RH		
	A-00325	LH,MED	GUIDE BLOCK, MED STILE, LH		
	A-00327	RH,MED	GUIDE BLOCK, MED STILE, RH		
5	T-00087		WASHER, LOCK, EXT, 1/4 ID, ZINC	4	Keep screws from moving up/down Screw Hole
6	T-00064		HHCS,1/4-20x0.750L.,ZINC	4	Secure Guide Block to Stile
7	A-00666	RH	PIVOT :2 PANEL TRACKLESS:RH	1	Swing Open Slide Door
	A-00667	LH	PIVOT :2 PANEL TRACKLESS:LH		
8	M-00606		BUSHING, BOTTOM PIVOT, SWING PANEL	1	Seat the Pivot Pin located inside Door Stile
9	T-00383		FHMS:14 x1.500L.:PHIL: SS	3	Secure Pivot Assembly to floor
10	T-00314		SCREW ANCHOR, #16 X 1" LG	3	Anchor screws into floor
11	T-00084		WASHER,.313 ID,.734 OD,.065 THK,ZINC	3	Raise/Lower Door Height
12	T-00015		FHMS,1/4-20x0.750L.,PHIL,ZINC	1	Secure washers to Pivot Assembly
13	M-01107		PIVOT ,BOTTOM,SWING PANEL	1	House (1-3) Washers and Screw

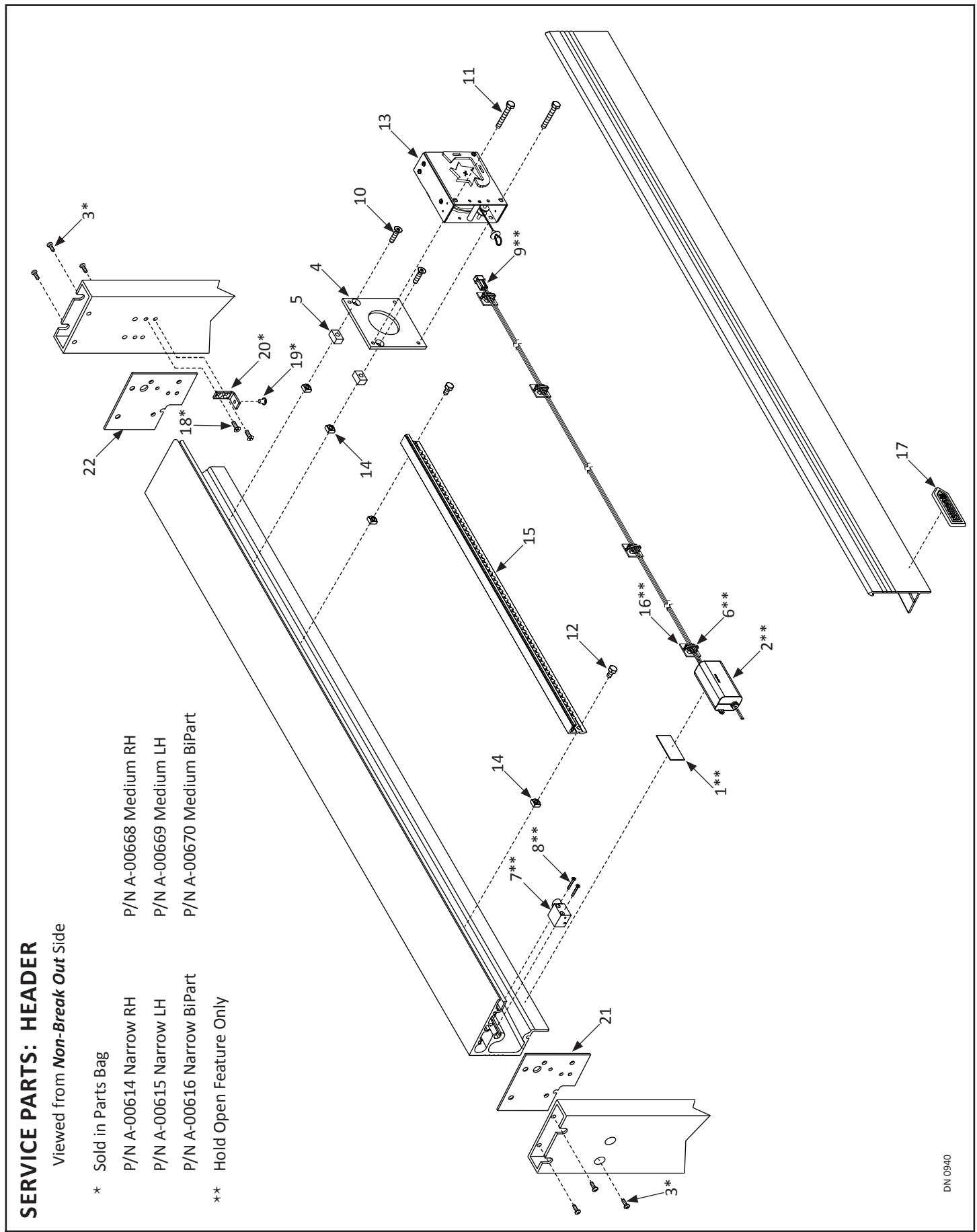

SERVICE PARTS: HEADER

Viewed from *Non-Break Out* Side

* Sold in Parts Bag

P/N A-00614 Narrow RH

P/N A-00668 Medium RH

P/N A-00615 Narrow LH

P/N A-00669 Medium LH

P/N A-00616 Narrow BiPart

P/N A-00670 Medium BiPart

** Hold Open Feature Only

Header			
Item	Part	Finish/Sizes/Notes	Description
1	14-13769	Hold Open Feature Only	TAPE, DBL. SIDE, FOAM 1" X 2" .045THK
2	V-00022	Hold Open Feature Only	POWER SUPPLY, 24VDC, 0.5A
3	T-00326		RHMS,1/4-20x0.750L.,PHIL,ZINC SELF TAPNG
4	14-14326		PULL SPRING MOUNTING BRACKET
5	14-14327		PULL SPRING SPACER
6	T-00195	Hold Open Feature Only	CABLE TIE,3/32 X 4.000L.
7	11-14344-10	RH/Hold Open Feature Only	ASSEMBLY, SELF-CLOSING ICU DOOR STOP RH
	11-14344-20	LH/Hold Open Feature Only	ASSEMBLY, SELF-CLOSING ICU DOOR STOP LH
8	24-0011-52	For Hold Open Feature	FHMS,1/4-20 X 1 3/4,SKT
9	11-14352	Hold Open Feature Only	HARNESS,SELF-CLOSING ICU HEADER
10	24-0011-21		FHCS, 1/4-20 X 1", ZN
11	T-00028		HHCS,1/4-20x1.750L.,GR5,ZINC
12	T-00464		HHCS,1/4-20X0.500.,ZINC
13	A-01274		SPRING, PULL - MACHINED
14	T-00058		NUT,SQ.,1/4-20,ZINC
15	24-14304		MACHINED CONTROL RACK
16	T-00165	Hold Open Feature Only	MOUNT, WIRE TIE, 1X1
17	C-00067		"NAMEPLATE, ADHESIVE BACKED"
18	T-00016		FHMS,1/4-20x0.438L.,PHIL,UNDERCUT,ZINC
19	T-00323		RHMS,8-32x0.250L.,PHIL,ZINC
20	M-01049		CLIP, COVER
21	A-01287		END CAP, FOR POCKETED JAMBS, LH
22	A-01289		END CAP, FOR POCKETED JAMBS, RH

SERVICE PARTS: CARRIER

Viewed from *Non-Break Out* Side

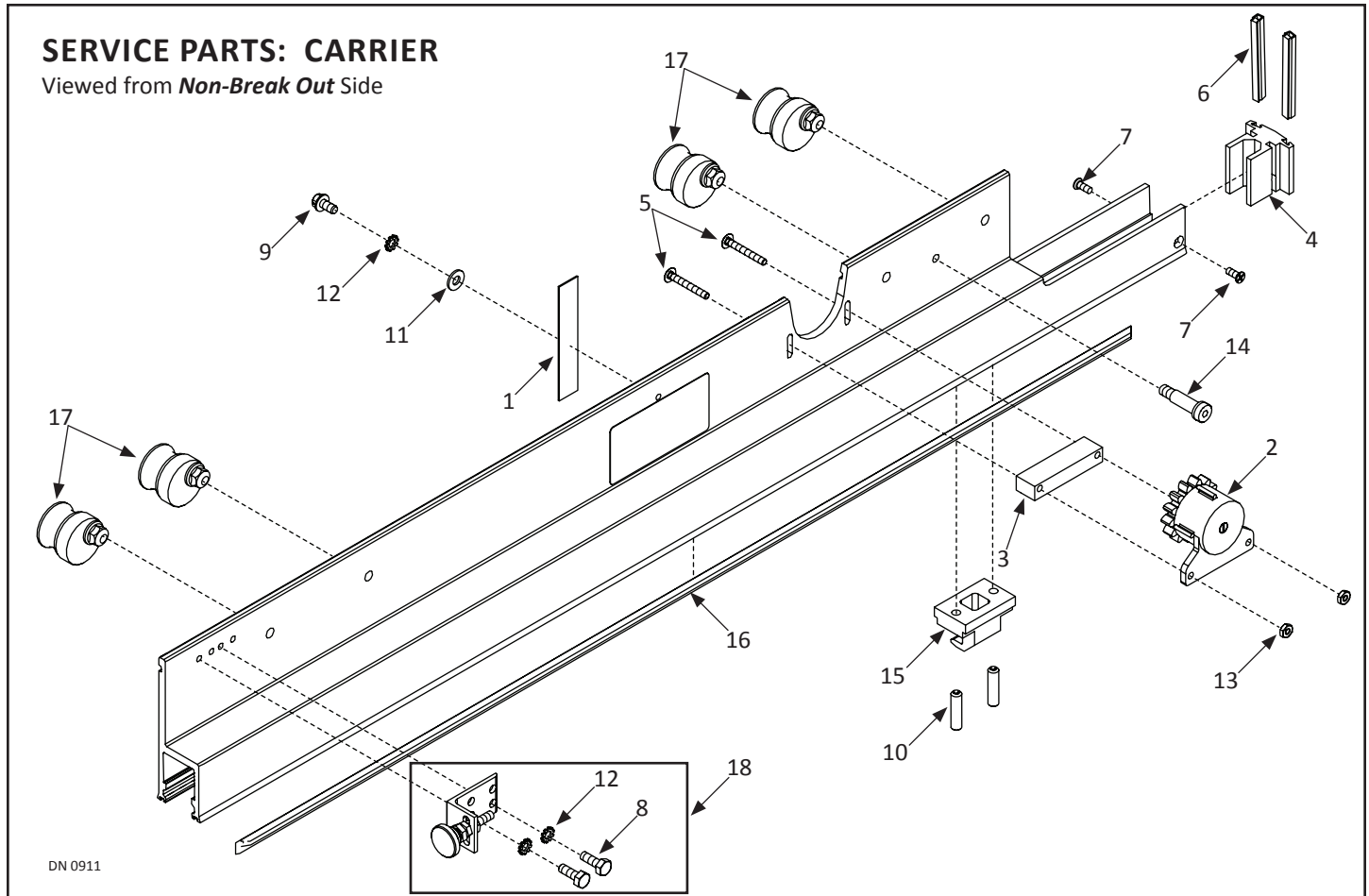

DN 0911

Carrier

Item	Part	Finish/Sizes/Notes	Description
1	M-01275		STATIC ARRESTOR,STRIP 4"
2	V-00519		"DAMPER,ROTARY"
3	A-01259		SPACER,ROTARY DAMPER
4	11-14322		ASSEMBLY,SELF-CLOSING ICU LEAD CARRIER END CAP
5	14-14329		CARRIAGE SCREW,10-24 X 1.5", ZN
6	M-01244		WEATHERING,BULB
7	T-00184		FHMS,10-32x0.500L.,PHIL,UCUT,TRI-LOBE,ZN
8	T-00064		HHCS,1/4-20x0.750L.,ZINC
9	T-00346	Green	HHCS:1/4-20x0.375L:GREEN:WASH HD:SLOT
10	T-00091		SHSS,5/16-18x1.250L.,CUP PT.
11	T-00054		WASHER,.281 ID,.625 OD,.065 THK,ZINC
12	T-00087		WASHER, LOCK, EXT, 1/4 ID, ZINC
13	T-00367		NUT:HEX:10-24:ZN
14	T-00389		"BOLT,SHLDR.,3/8x1.000L.,5/16-18THD"
15	M-00483		PANIC CATCH RELEASE ASSEMBLY
16	24-9094		DOOR CARRIER INTERFACE LEG
17	A-00416		ROLLER HANGER,30mm
18	A-01284		ASSEMBLY, HOLD OPEN BRACKET

SERVICE PARTS: FULL OPEN SIDELITE

Viewed from *Non-Break* Out Side

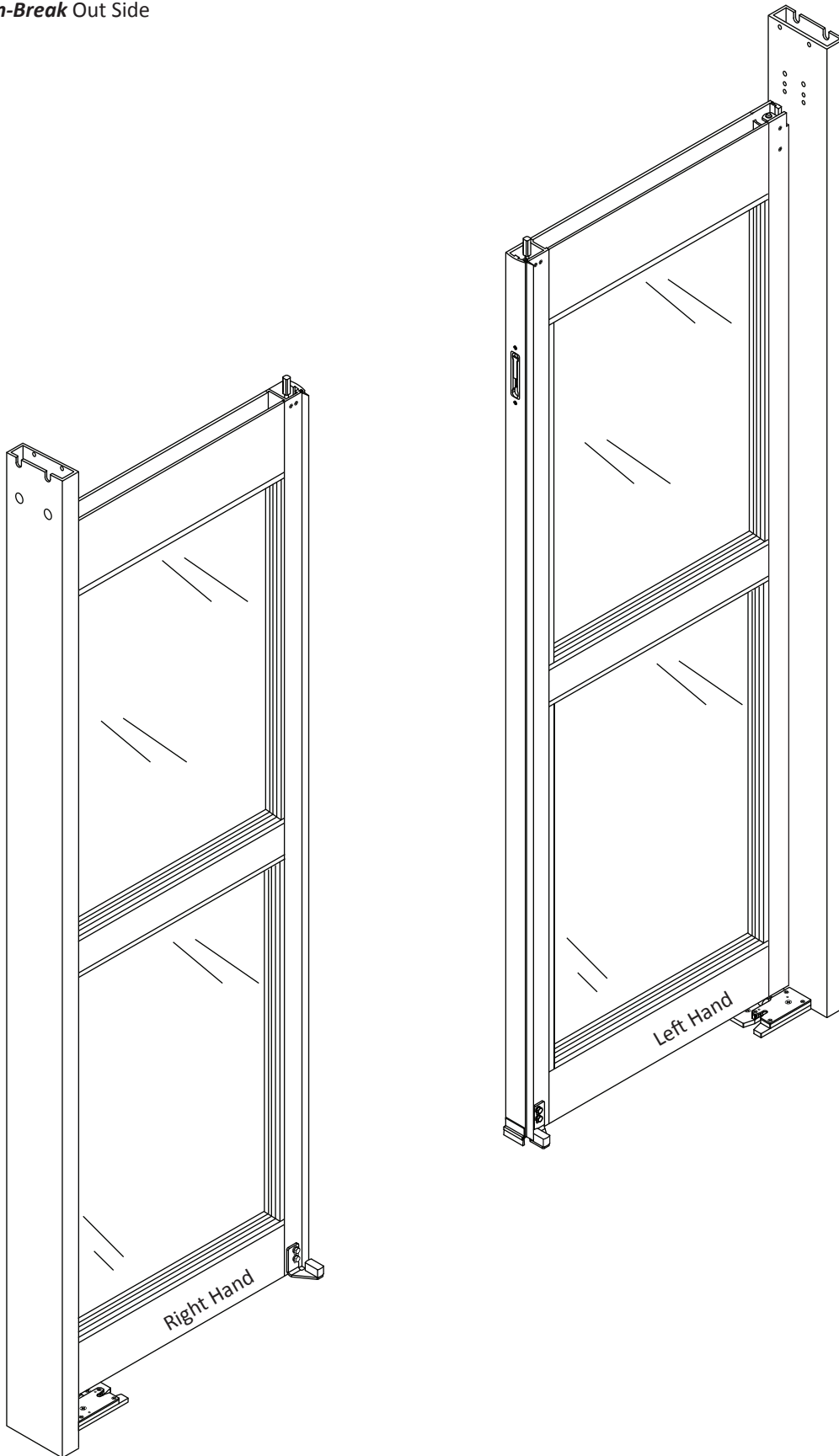

DN 0921

SERVICE PARTS: RIGHT HAND

FULL OPEN SIDELITE

Viewed from Non-Break Out Side

* Sold in Parts Bag:

P/N A-00614 Narrow RH

P/N A-00615 Narrow LH

P/N A-00616 Narrow BiPart

P/N A-00668 Medium RH

P/N A-00669 Medium LH

P/N A-00670 Medium BiPart

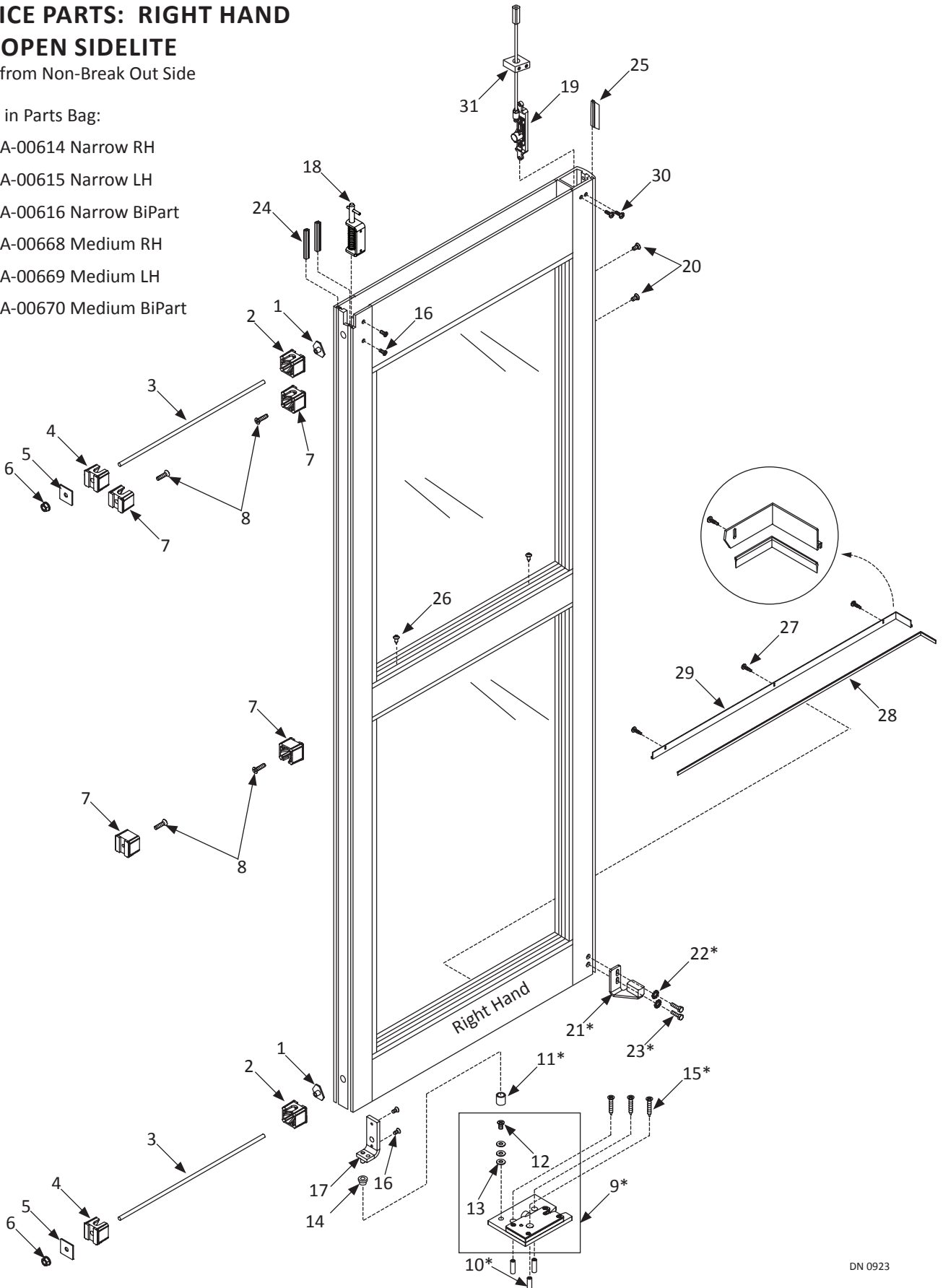

DN 0923

SERVICE PARTS: LEFT HAND FULL OPEN SIDELITE

Viewed from Non-Break Out Side

- * Sold in Parts Bag
- P/N A-00614 Narrow RH
- P/N A-00615 Narrow LH
- P/N A-00616 Narrow BiPart
- P/N A-00668 Medium RH
- P/N A-00669 Medium LH
- P/N A-00670 Medium BiPart

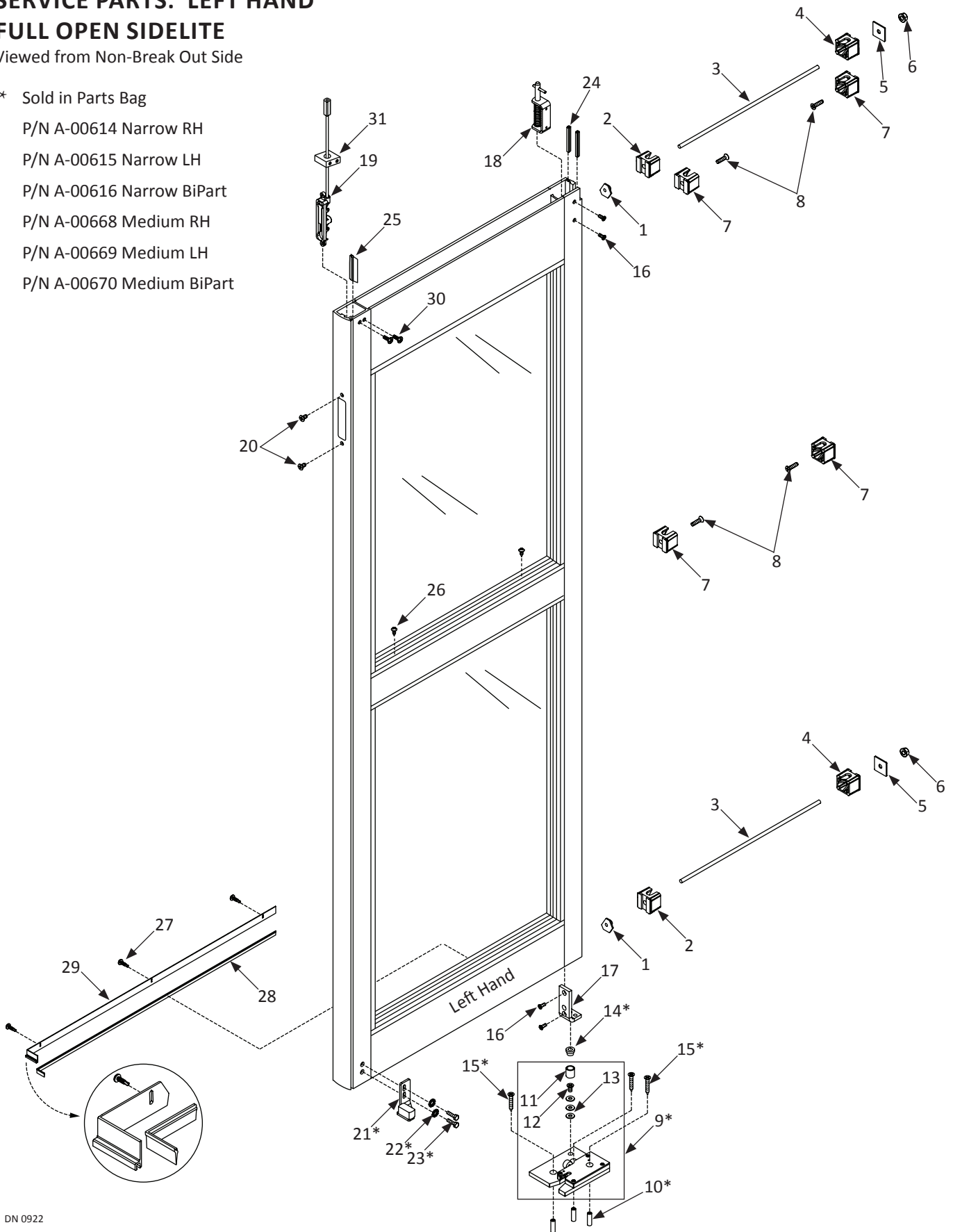

Sidelite			
Item	Part	Finish/Sizes/Notes	Description
1	M-00416		T-NUT, 3/8"-16, TIE ROD
2	M-00460		CLIP,MUNTIN,.500 HOLE
3	M-00272		3/8-16 THREADED ROD
4	M-00461		CLIP,MUNTIN,.386 HOLE
5	M-00422		PLATE,TIE ROD
6	T-00025		NUT,WHIZLOCK,3/8-16,ZINC
7	M-00462		CLIP,MUNTIN,.261 HOLE
8	T-00061		FHMS,1/4-20x1.000L.,PHIL,TRI-LOBE,ZINC
9	A-00666		PIVOT :2 PANEL TRACKLESS:RH
	A-00667		PIVOT :2 PANEL TRACKLESS:LH
10	T-00314		SCREW ANCHOR, #16 X 1" LG
11	M-01107		PIVOT ,BOTTOM,SWING PANEL
12	T-00015		FHMS,1/4-20x0.750L.,PHIL,ZINC
13	T-00084		WASHER,.313 ID,.734 OD,.065 THK,ZINC
14	M-00606		BUSHING, BOTTOM PIVOT, SWING PANEL
15	T-00383		FHSMS:14 x1.500L.:PHIL: SS
16	T-00184		FHMS,10-32x0.500L.,PHIL,UCUT,TRI-LOBE,ZN
17	M-00594	RH	PIVOT, SWING PANEL,BTM,RH
	M-00593	LH	LH BOTTOM PIVOT SWING PANEL
18	A-00029		ASM, TOP PIVOT, 1175 SWING PANEL
19	A-00332	Clear	FLUSH BOLT, W/ CUT,204
	A-00382	Dark Bronze	FLUSH BOLT, W/ CUT.313
20	T-00043		FHMS,10-24x0.375L.,PHIL,UNDERCUT,ZINC
21	A-00318	LH	GUIDE BLOCK, NAR STILE, LH
	A-00321	RH	GUIDE BLOCK, NARR STILE, RH
	A-00325	LH	GUIDE BLOCK, MED STILE, LH
	A-00327	RH	GUIDE BLOCK, MED STILE, RH
22	T-00087		WASHER, LOCK, EXT, 1/4 ID, ZINC
23	T-00139		HHCS,1/4-20x1.000L.,GR5,ZINC
24	M-01244	Black	WEATHERING,BULB
25	M-01241	Smoke Seal Only/Gray	WEATHERING, VINYL, 9/16IN GRAY FIN
	M-71241	Smoke Seal Only/Black	WEATHERING,VINYL,9/16IN,BLK
26	T-00098		PHSMS,10x0.563L.,PHIL,TYPE A
27	T-00222	Smoke Seal Only/Zinc	PHSMS,6x0.500L.,PHIL,TEKS,ZINC
	T-00260	Smoke Seal Only/Black Oxide	PHSMS,6x0.500L. PHIL,TEKS BLK ZN
28	M-01239	Smoke Seal Only/Gray	WEATHERING, VINYL, 1IN GRAY FIN
	M-71239	Smoke Seal Only/Black	WEATHERING:VINYL:1.00:BLK

Sidelite			
Item	Part	Finish/Sizes/Notes	Description
29	14-10659-01	Smoke Seal Only/LH/Clear	WEATHERING HOLDER
	14-10659-02	Smoke Seal Only/LH/Dark Bronze	WEATHERING HOLDER
	14-10660-01	Smoke Seal Only/RH/Clear	WEATHERING HOLDER
	14-10660-02	Smoke Seal Only/RH/Dark Bronze	WEATHERING HOLDER
30	T-00182		PHMS,10-32x0.500L.,PHIL,F-POINT,ZINC
31	M-00100		BLOCK, 2100 GUIDE LOCK, ROD END

SERVICE PARTS: SLIDE DOOR

Viewed from *Non-Break Out* Side

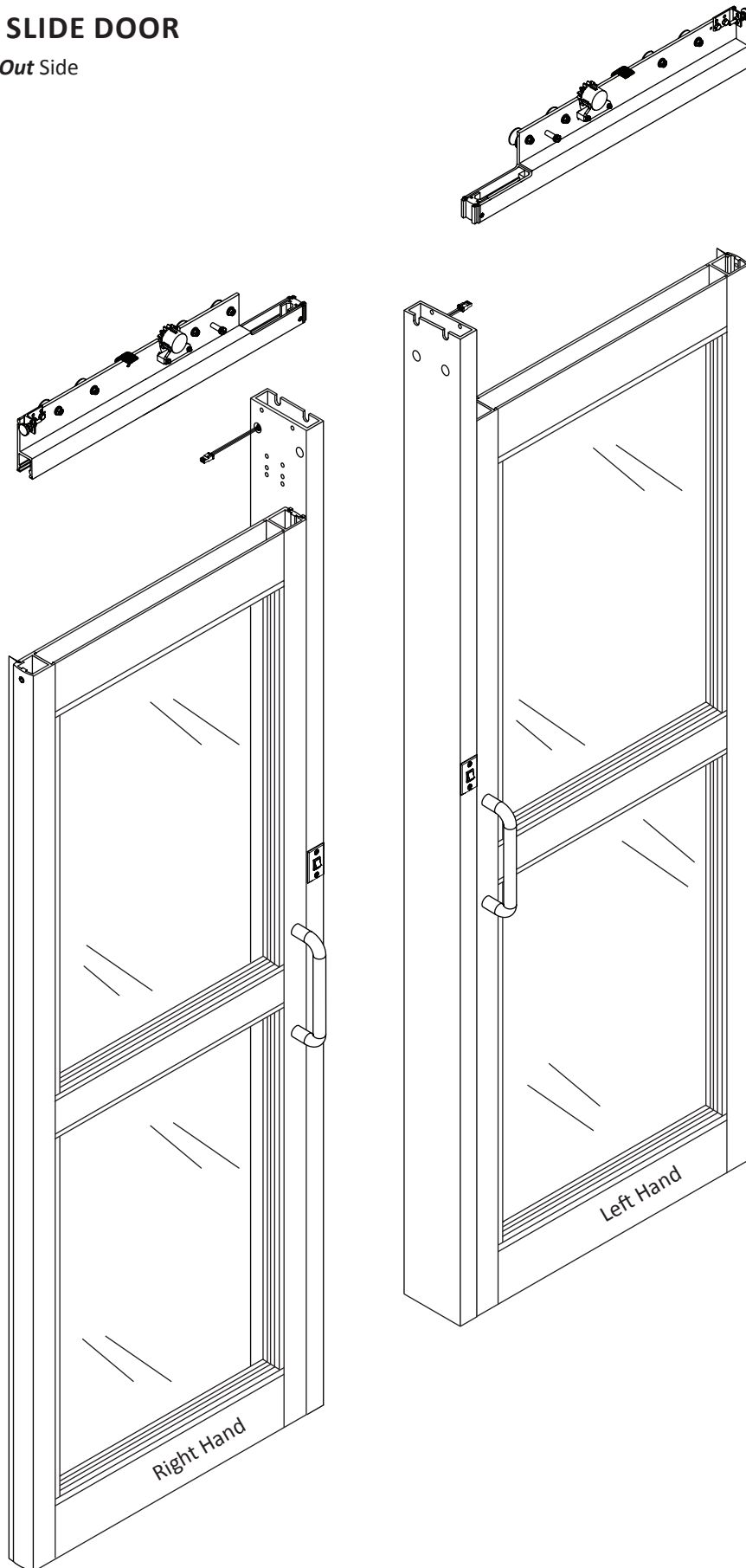

DN 0913

SERVICE PARTS: RIGHT HAND SLIDE DOOR

Viewed from *Non-Break Out* Side

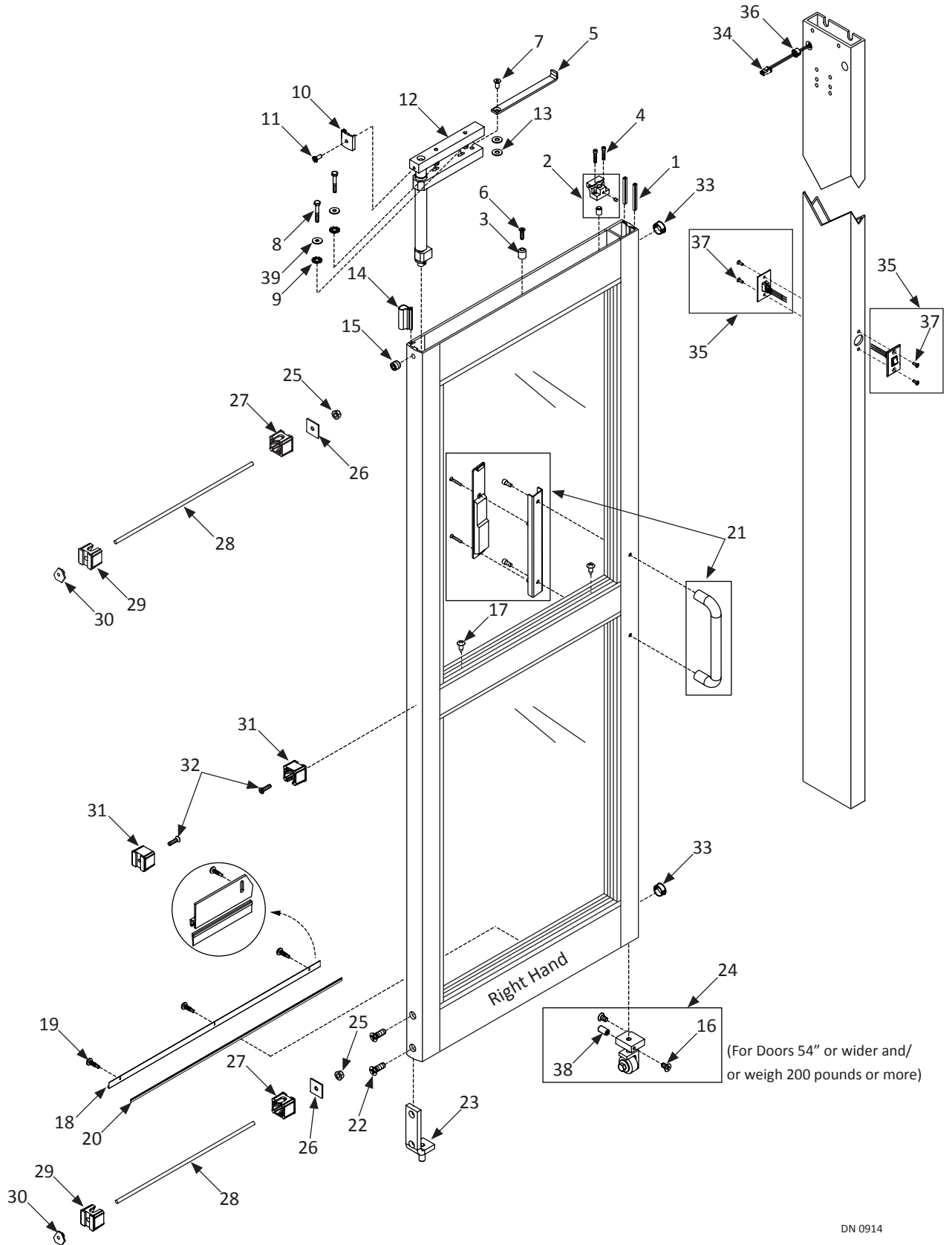

SERVICE PARTS: LEFT HAND SLIDE DOOR

Viewed from *Non-Break Out* Side

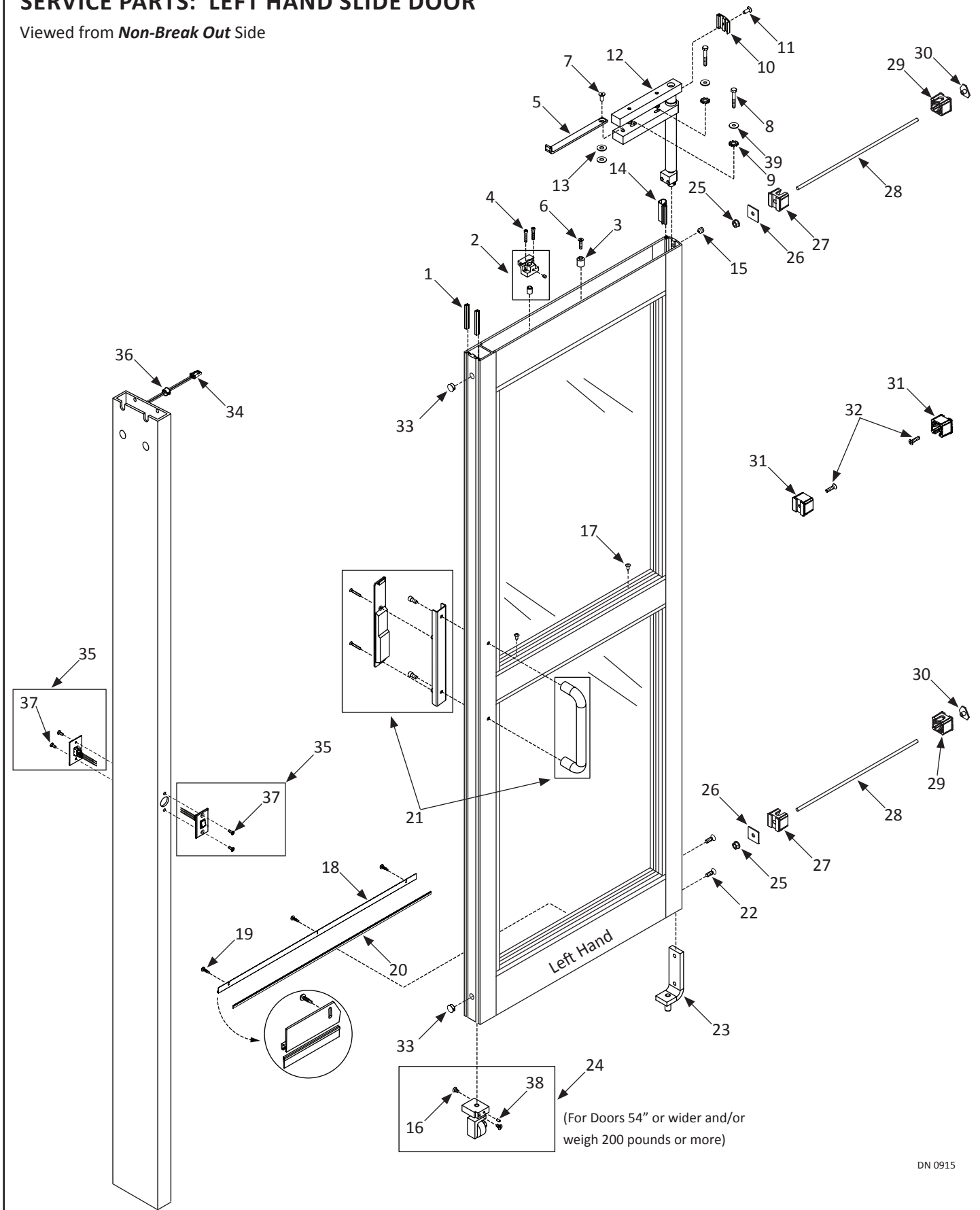

Slide Door			
Item	Part	Finish/Sizes/Notes	Description
1	M-01244		WEATHERING,BULB
2	A-01128		PANIC CATCH,BOTTOM;MODEL1100;W-1/8WALL
3	M-00653		BRACKET, LIMIT ARM SUPPORT
4	T-00037		SHCS,1/4-20x1.250L.,ZINC
5	M-00379		LIMIT ARM, STANDARD STILES
6	T-00061		FHMS,1/4-20x1.000L.,PHIL,TRI-LOBE,ZINC
7	T-00018		FHCS,7/16-14x1.000L.,ZINC
8	T-00028		HHCS,1/4-20x1.750L.,GR5,ZINC
9	T-00087		WASHER, LOCK, EXT, 1/4 ID, ZINC
10	M-01255	Clear	END CAP,7/16x1-7/8,204
	M-71255	Dark Bronze	END CAP,7/16x1-7/8,313
11	T-00183	Black Zinc	FHMS,10-32x0.500L.,PHIL,UCUT,23-PT,BLKZN
	T-00176		FHMS,10-32x0.500L.,PHIL,UCUT,23-PT,ZINC
12	A-00092		CARRIER,PIVOT,NARROW STILE
	A-00165		CARRIER, PIVOT ASSY, MED STILE
	A-00168		CARRIER PIVOT ASM. NRW PANEL & STILE
	A-00172		CARRIER,PIVOT,ASM.,NRW.PNL - MED.STILE
13	T-00092		WASHER,.438 ID,1.00 OD,.083 THK,ZINC
14	M-01241	Smoke Seal Only/Gray	WEATHERING, VINYL, 9/16IN GRAY FIN
	M-71241	Smoke Seal Only/Black	WEATHERING,VINYL,9/16IN,BLK
15	T-00261	Black Oxide	SHSS,5/16-24x0.500L.,CUP PT.
16	T-00016		FHMS,1/4-20x0.438L.,PHIL,UNDERCUT,ZINC
	T-00108	Black Oxide	FHMS,1/4-20x0.438L.,PHIL,UNDERCUT,BLK ZN
17	T-00098		PHSMS,10x0.563L.,PHIL,TYPE A
18	24-9125-01	Smoke Seal Only/Clear	WEATHERING EXT, 204
	24-9125-02	Smoke Seal Only/Dark Bronze	WEATHERING EXT, 313
19	T-00222	Smoke Seal Only/Zinc	PHSMS,6x0.500L.,PHIL,TEKS,ZINC
	T-00260	Smoke Seal Only/Black Zinc	PHSMS,6x0.500L. PHIL,TEKS BLK ZN
20	M-01239	Smoke Seal Only/Gray	WEATHERING, VINYL, 1IN GRAY FIN
	M-71239	Smoke Seal Only/Black	WEATHERING:VINYL:1.00:BLK
21	A-00988	Clear	HANDLE,D & RECESSED;KIT,204
	A-00989	Dark Bronze	HANDLE,D & RECESSED;KIT;313
22	T-00017		FHMS,1/4-20x0.750L.,PHIL,BLK ZN
23	M-01414		PIVOT:BOTTOM:TELESCOPIC ICU
24	A-00198		NOSE CASTER ASSY, NAR
	A-00207		NOSE CASTER ASSY, MED
25	T-00025		NUT,WHIZLOCK,3/8-16,ZINC
26	M-00422		PLATE,TIE ROD
27	M-00461		CLIP,MUNTIN,.386 HOLE

Slide Door			
Item	Part	Finish/Sizes/Notes	Description
28	M-00272		3/8-16 THREADED ROD
29	M-00460		CLIP,MUNTIN,.500 HOLE
30	M-00416		T-NUT, 3/8"-16, TIE ROD
31	M-00462		CLIP,MUNTIN,.261 HOLE
32	T-00061		FHMS,1/4-20x1.000L.,PHIL,TRI-LOBE,ZINC
33	V-00720		PLUG,HOLE,13/16 DOME
34	11-14349		HARNES,SELF-CLOSING ICU STRIKE JAMB
35	A-01285		SWITCH PANEL,ROCKER - 2 WAY ASM
36	V-00257		BUSHING,ELECTRICAL,0.750 HOLE
37	T-00031	Black Oxide	FHMS,10-32x0.500L.,PHIL,UCUT,T-LOBE,BKZN
38	T-00105		SHSS,8-32x0.313L.,CUP PT.
39	T-00029		WASHER,.250 ID,.563 OD,.049 THK,ZINC