



NAX Hermetic Slide Door Installation Manual

****with U30 Control****

P/N C-00307 Rev 12-15-17

Nabco Entrances Inc. S82 W18717 Gemini Drive Muskego, Wisconsin 53150
Phone: (877) 622-2694 Fax: (888) 679-3319 www.nabcoentrances.com
NABCO hours of Operation: Monday to Friday 8:00 a.m.- 4:30 p.m. (Central Time)

*Associated Manuals Part Numbers: NABCO Price Book (for Sensors, Switches, and Accessories)
U30 Microprocessor Control Setup and Programming Manual P/N C-00203
GT1175 Electrical Installation Manual **with U30 Microprocessor Control** P/N C-00198
NAX Hermetic Slide Door Owners Manual P/N C-00308*

DANGER

All installation and service shall be done by a qualified NABCO trained technician.

WARNING

- Turn OFF all power to the Automatic Door if a Safety System is not working.
- Instruct the Owner to keep all power turned OFF until corrective action can be achieved by a NABCO trained technician. Failure to follow these practices may result in serious consequences.
- NEVER leave a Door operating without all Safety detection systems operational.

Attention: Finished Opening and Clear Opening are two different measurements. For detailed information please refer to SECTION 4.6.

Table of Contents

CHAPTER 1: WARNING LABELS 4

CHAPTER 2: GENERAL SAFETY RECOMMENDATIONS 4

CHAPTER 3: SCOPE 5

SECTION 3.1: To the Installer 5

SECTION 3.2: Objective 5

CHAPTER 4: GETTING STARTED 5

SECTION 4.1: Features 5

SECTION 4.2: Model Specifications 6

SECTION 4.3: Extrusion Specifications 6

SECTION 4.4: Important Anchor Information 6

SECTION 4.5: Performance Values 7

SECTION 4.6: Opening Sizes 8

CHAPTER 5: PREPARE THE MOUNTING SURFACE (OR FRAME) 9

SECTION 5.1: Ensure the Finished Opening is Plumb and Square 10

SECTION 5.2: Measure Inside the Finished Opening 10

CHAPTER 6: INSTALL THE JAMB TUBES 10

CHAPTER 7: PREPARE THE HEADER 12

SECTION 7.1: Drill (1) Access Hole for 120 VAC Wiring and Holding Beam Wire(s) 12

SECTION 7.2: Drill (1) Access Hole for other Holding Beam Wire(s) 12

SECTION 7.3: Drill Anchor Holes 12

SECTION 7.4: Drill Cover Screw Holes 13

CHAPTER 8: INSTALL THE HEADER 13

SECTION 8.1: Determine Bottom of Header Horizontal Position 13

SECTION 8.2: Determine Top of Header Horizontal Position 14

SECTION 8.3: Determine Strike Side of Header Vertical Position 14

CHAPTER 9: INSTALL THE HOLDING BEAMS 15

SECTION 9.1: Insert Holding Beams within Channels. 15

SECTION 9.2: Wire the Holding Beams to the Holding Beam Controller 16

CHAPTER 10: INSTALL SLIDE BOLTS INTO HEADER. 16

CHAPTER 11: INSTALL THE DOOR STOPS 16

CHAPTER 12: INSTALL THE STRIKE BOTTOM GUIDE 17

CHAPTER 13: INSTALL THE TRAIL BOTTOM GUIDE 18

CHAPTER 14: INSTALL THE SLIDE DOOR 19

SECTION 14.1: Install the Rubber Bumper 19

SECTION 14.2: Install Roller Carriers 20

SECTION 14.3: Hang Slide Door onto Header Track 21

SECTION 14.4: Install the Belt Clip. 23

SECTION 14.5: Install the Idler Pulley 23

CHAPTER 15: INSTALL HEADER COMPONENTS. 24

SECTION 15.1: Install the Motor/Operator 24

SECTION 15.2: Install the Drive Belt 25

SECTION 15.3: Install the Power Supply 26

SECTION 15.4: Install the U30 Controller 27

SECTION 15.5: Install the Holding Beam Controller 27

SECTION 15.6: Install the Spring Mechanism Receiver 28

SECTION 15.7: Install Wiring Clips 29

CHAPTER 16: 120 VAC GENERAL WIRING 29

CHAPTER 17: INSTALL THE SPRING MECHANISM TO DOOR. 30

SECTION 17.1: Set Preload (Spring Force) 30

SECTION 17.2: Secure Spring Mechanism to the Mounting Plate. 31

SECTION 17.3: Ensure Proper Slide Door Movement. 32

SECTION 17.4: Ensure Slide Door is Hermetically Sealed. 32

CHAPTER 18: GENERAL WIRING 33

SECTION 18.1: Passive Activation Devices. 33

SECTION 18.2: Passive Activation Devices (ON/OFF/HOLD-OPEN Switch) 34

- SECTION 18.3: Powered Activated Devices 34
- SECTION 18.4: Safety Sensors 34
- SECTION 18.5: Safety Sensors with Monitoring 35
- SECTION 18.6: Powered Activation Devices (ON/OFF/HOLD-OPEN Switch) 35
- CHAPTER 19: HANDY TERMINAL PROGRAMMING 35**
- CHAPTER 20: INSTALL THE HEADER COVER 36**
- CHAPTER 21: INSTALL THE END CAPS 37**
- CHAPTER 22: INSTALL THE DOOR HANDLE 38**
- CHAPTER 23: ADJUSTMENTS 38**
 - SECTION 23.1: Adjust the Spring Mechanism 38
 - SECTION 23.2: Adjust Roller Movement within Track 39
 - SECTION 23.3: Adjust the Drive Belt 39
 - SECTION 23.4: Adjust Small Gap between Door and the Floor 40
 - SECTION 23.5: Adjust Large Gap between Door and the Floor 40
 - SECTION 23.6: Adjust Gap between the Strike End of Door and the Jamb Tube 41
 - SECTION 23.7: Adjust Gap between the Trail End of Door and the Jamb Tube 41
- CHAPTER 24: WEATHERING 42**
- CHAPTER 25: TROUBLESHOOTING 44**
- CHAPTER 26: CONVERSION CHART 45**
- SERVICE PARTS: NABCO KIT P/N A-01367 47**
- SERVICE PARTS: NABTESCO DOOR 48**

CHAPTER 1: WARNING LABELS

Warning labels are universal and used to alert an individual of potential harm to one's self or to others. The following warning labels are listed in a hierarchy order that defines the most potential danger first, and the least potential danger last. Please refer to this page in the event that a warning label is displayed within this manual and further definition needs to be explained.

DANGER

Indicates potentially dangerous situations. Danger is used when there is a hazardous situation where there is a *high* probability of severe injury or death. It should not be considered for property damage unless personal injury risk is present.

WARNING

Indicates a hazardous situation which has *some* probability of severe injury. It should not be considered for property damage unless personal injury risk is present.

CAUTION

Indicates a hazardous situation which *may result in a minor injury*. Caution should not be used when there is a possibility of serious injury. Caution should not be considered for property damage accidents unless a personal injury risk is present.

Attention: A situation where material could be damaged or the function impaired.

Notice: Indicates a statement of company policy as the message relates to the personal safety or protection of property. Notice should not be used when there is a hazardous situation or personal risk.

Note: Indicates important information that provides further instruction.

CHAPTER 2: GENERAL SAFETY RECOMMENDATIONS

WARNING

Do not install, operate or service this product unless you have read and understand the General Safety Recommendations, Warning Labels, contained in this manual. Failure to do so may result in bodily injury, or property damage.

WARNING

Read, study and understand the installation and operating instructions contained in, or referenced in this manual before operating. If you do not understand the instruction, ask a qualified technician. Failure to do so may result in bodily injury, or property damage and will nullify all warranties.

WARNING

These installation instructions are aimed to end users who can understand the language written within this manual. If this is not the case or any persons who do not understand the language use or service this door system, give such workers safety educations and handling instructions on the customer's responsibility.

WARNING

Before Installation: surround the Door System with a safety fence, etc. to prevent persons other than workers from entering the working zone.

WARNING

Do Not hang or detach Slide Door alone. Always work with another NABCO trained technician. Working alone may result in injury by fallen door.

WARNING

A hand can get caught by unexpected movement of the door. Before turning ON the power, confirm the followings:

- There is no person nor object on the sliding door track.
- The sliding door is at its fully closed position.

DANGER

Disconnect all power to the junction box prior to making any electrical connections. Failure to do so may result in serious personal or fatal injury. When uncertain whether power supply is disconnected, always verify using a voltmeter.

DANGER

Do not place finger or uninsulated tools inside the electrical controller. Touching wires or other parts inside the enclosure may cause electrical shock, serious injury or death.

DANGER

Immediately shut down the power if any abnormal sound or smell, and/or smoke are generated after the power is turned ON. It may result in a fire.

CAUTION

Never disassemble nor modify the NAX Hermetic Slide Door. Nabtesco Corporation is not liable for any damages nor problems caused by such disassembly or modification by customers.

CAUTION

If the door appears broken or does not seem to work correctly, it should be immediately removed from service until repairs can be carried out or a qualified service technician is contacted for corrective action.

Notice: This manual, the owner's manual and all other associated manuals must be given to and retained by the purchasing facility or end user.

Notice: Wiring must meet all local, state, federal or other governing agency codes.

Notice: All electrical troubleshooting or service must be performed by qualified electrical technicians and must comply with all applicable governing agency codes.

Note: For the disposal of this door system, confirm and observe the relative laws, standards, bylaws, and/or regulations of the nation or region where this door system is used.

CHAPTER 3: SCOPE

SECTION 3.1: To the Installer

The purpose of this manual is to familiarize the installer and purchaser with the proper installation and operation of this system. It is essential that this equipment be properly installed and operational before the door is used by the public. It is the installer's responsibility to inspect the operation of the entrance system to be sure it complies with any applicable standards.

Instruct the building owners and operator on the essentials of the operation of the door and this device. The owner should follow these instructions to determine whether the door is operating properly and should immediately call for service if there is any malfunction. All installation changes and adjustments must be made by qualified, NABCO trained technicians.

SECTION 3.2: Objective

The NAX Hermetic Slide Door system is designed to be installed within an existing Finished Opening. The door function is controlled by the Microprocessor U30 Control. This Control offers many features to accommodate most installation options. This manual offers step by step instructions.

CHAPTER 4: GETTING STARTED

In response to customer's special requirements, the NAX Hermetic Door is a Surface Mount, Automatic Slide Door that has been:

- ▶ Designed for rooms where airborne contagion control and air hygiene control is critical. Such as hospital operating rooms, infection wards, etc.
- ▶ Engineered to comply with Code JIS A 4702 Class A-4, for airtight performance.

Along with superior capabilities that can fill the needs of a hospital room, the NAX Hermetic Door system is also:

- ▶ Designed for rooms where sound control is critical. Such as meeting rooms, sound insulation rooms, etc.
- ▶ Engineered to comply with Code JIS A 4702, Class T-1, for sound insulation performance.
- ▶ Can be lined with (2mm) of lead to perform as a Low-Level Radiation Door.

SECTION 4.1: Features

- ▶ Vinyl Seals used to keep airborne contagions in/out, unwanted sound in/out, and radiation in/out.
- ▶ Structure can be made out of aluminum, or stainless steel, or all glass.
- ▶ A variety of Finishes, including Anti-Bacterial Paint.
- ▶ For a barrier-free design, a Threshold is not required, however an optional steel Threshold can be ordered.
- ▶ Slide Door can be fully opened/closed manually. If utilizing a recessed Handle there will be no need for clearance.

- ▶ During a power outage the Door:
 - Will remain fully closed as to maintain airtightness and sound control performance.
 - Can still be manually opened/closed at any time.
- ▶ Door has a flat structure with no frame(excluding framed glass doors).

SECTION 4.2: Model Specifications

Attention: NABCO recommends that an aluminum frame should be installed within the Finished Opening for the Jamb Tubes to secure to.

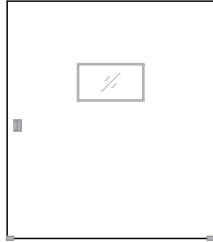
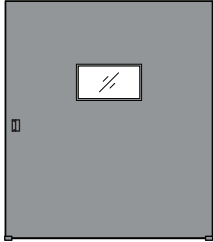
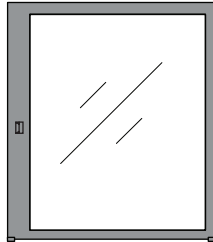
							
DN 1754 NAX-SN/NAX-SX Aluminum (AL)	NAX-SN/NAX-SX Stainless Steel (SUS)	NAX-SG Tempered Glass					
Model	Type	Structure and Finish	Airtight	Sound	X-Ray		
NAX-S	N	Aluminum Plate (Standard white paint Finish) *1	Yes	Yes	No		
		Stainless Steel Plate (SUS304), (Standard #150 Hairline Finish) *1					
		Honeycomb Core					
		Reinforced Frame (Aluminum Extruded Material)					
	X	Aluminum Plate (Standard white paint Finish) *1			Yes	Yes	
		Stainless Steel Plate (SUS304), (Standard #150 Hairline Finish) *1					
		Honeycomb Core					
		Reinforced Frame (Aluminum Extruded Material)					
	G	Lead Plate (2mm)				No	No
		Tempered Glass 8t					
4-sided Frame: Aluminum extruded material (Alumite treatment), Silver							
Glass Bead; Rubber (EPDM), Black							
	Glazing Rubber (EPDM), Black						
*1 For some width dimensions, a silicone caulking seam may be present.							

SECTION 4.3: Extrusion Specifications

Extrusion	Description
3-sided Jamb Tubes	Aluminum extruded material (Alumite treatment), silver color
	Rubber, black seals located at the top each door, and both sides of each door.
Header	Aluminum extruded material (Alumite treatment), silver color
Header Cover	
Header End Caps	
Threshold (Optional)	<ul style="list-style-type: none"> ▶ Stainless Steel Plate (Standard #150 Hairline Finish) ▶ Floor must be level. If not, original airtight performance can not be achieved. Thresholds can be used to level floors.

SECTION 4.4: Important Anchor Information

The NAX Hermetic Slide Door is shipped by the NABCO Factory with metric anchors and other hardware only. Please refer to the Conversion Chart at the back of this manual for detailed information.

SECTION 4.5: Performance Values

Performance Type	NAX-SN	NAX-SX	NAX-SG
Airtight *2	Class A-4	Class A-4	Class A-4
Sound Insulation	Class A-1	Class T-1	Class T-2
X-Ray *1	—	2mm Lead Thickness *1	—

*1 Standard lead lining (2mm) is for low level performance only. Optional thickness of lead lining can be ordered by calling customer service at 877-622-2694. Radiation Protection Standards vary for each country and the size of the boundary for controlled areas for X-rays. Each individual site must be inspected before ordering an X-ray Slide Door.

*2 Door will stay fully closed during a power failure. However, Door can still be manually opened/closed at any time.

4.5.1 Air Tight Performance Chart

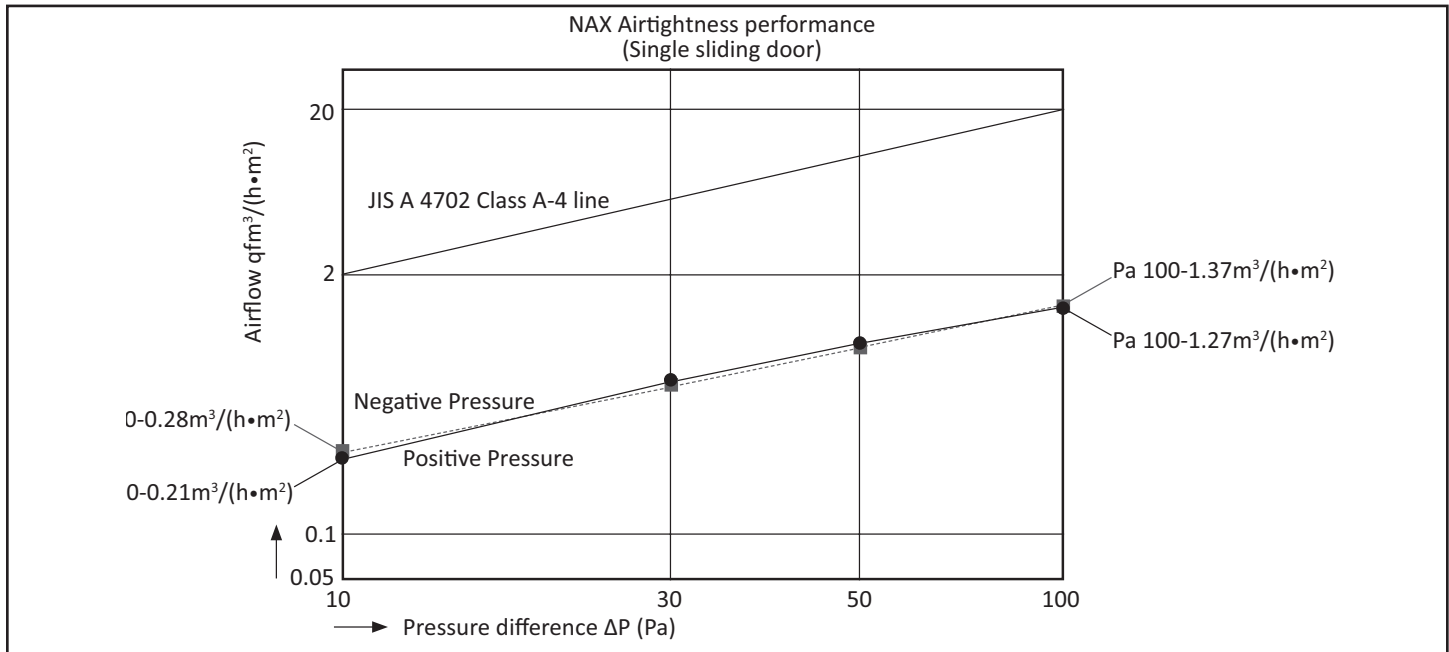

4.5.2 Sound Insulation Performance Chart

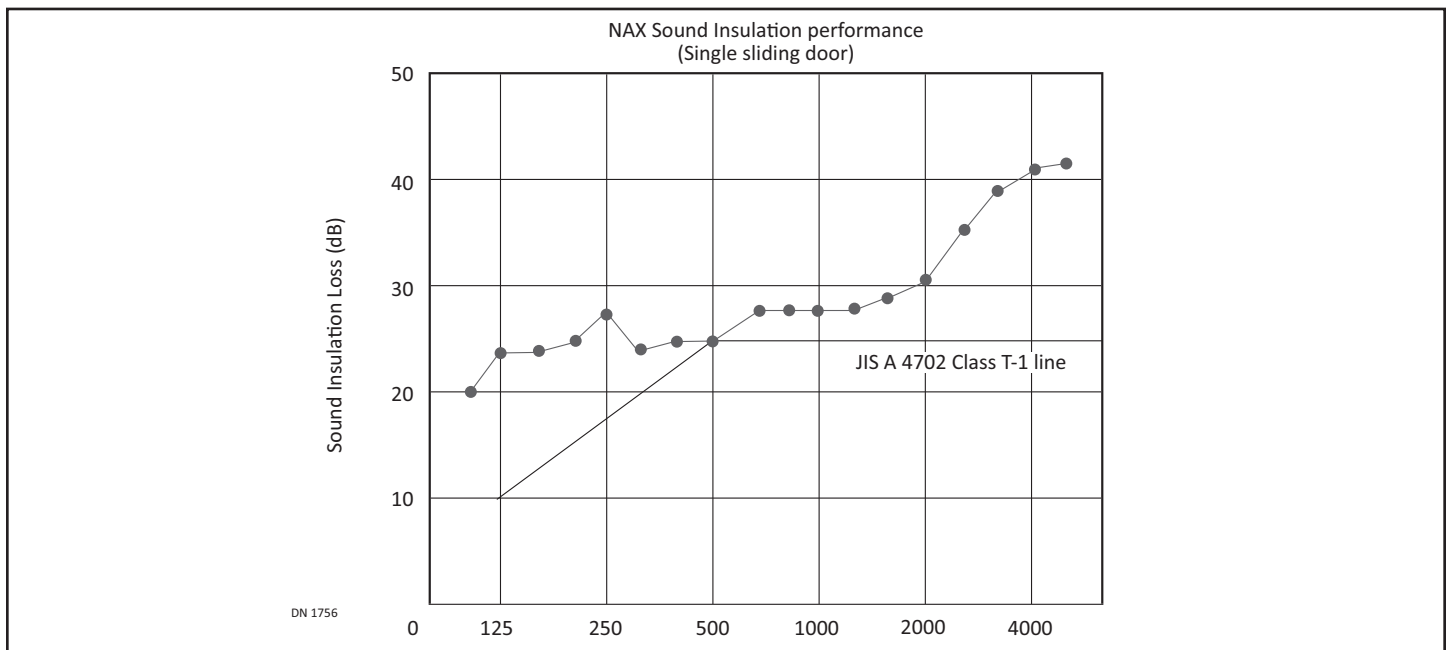

SECTION 4.6: Opening Sizes

4.6.1 Finished Opening

Finished Opening is the full width and full height of the opening within the wall, without any form of extrusions installed. Such as: an aluminum frame, or jamb tubes.

4.6.2 Clear Opening

Clear Opening is the full width and full height between installed jamb tubes, and the floor. For all applications, the Clear Opening will vary depending on the Structure/Finish.

4.6.3 NAX-SN

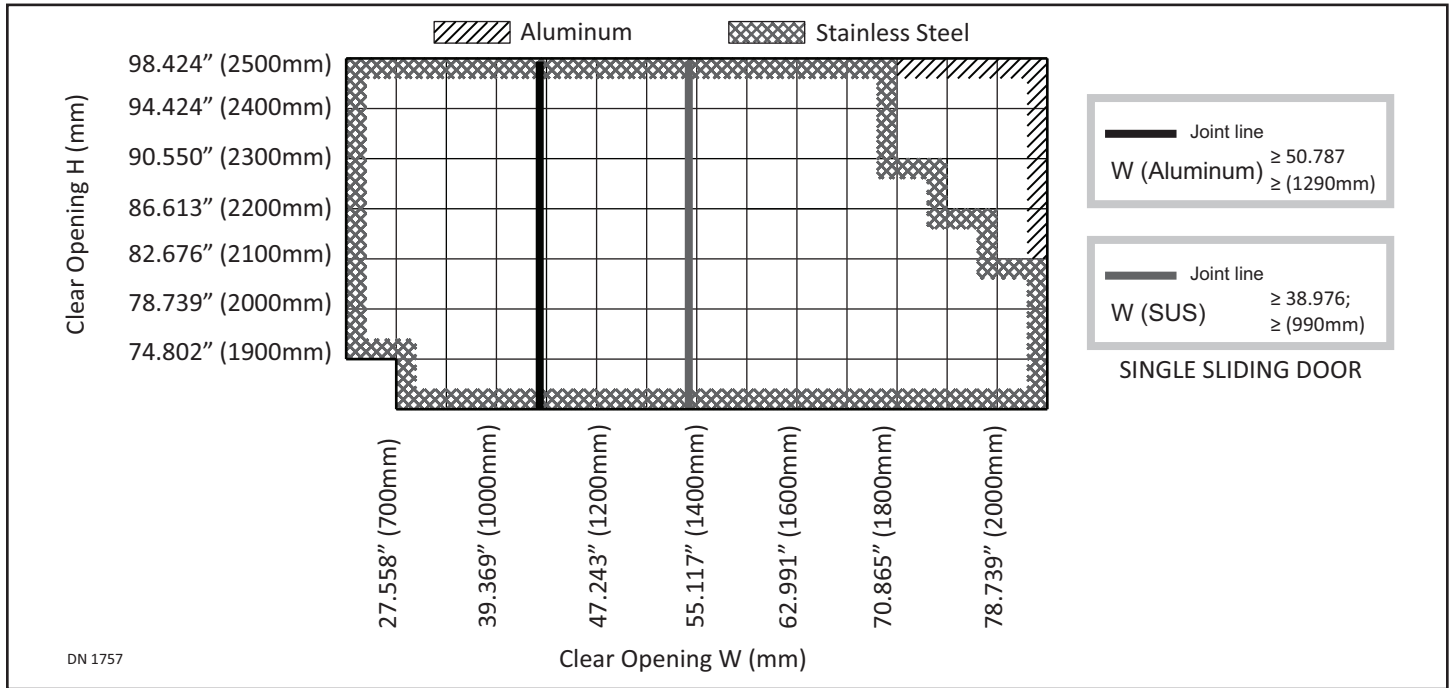

4.6.4 NAX-SX

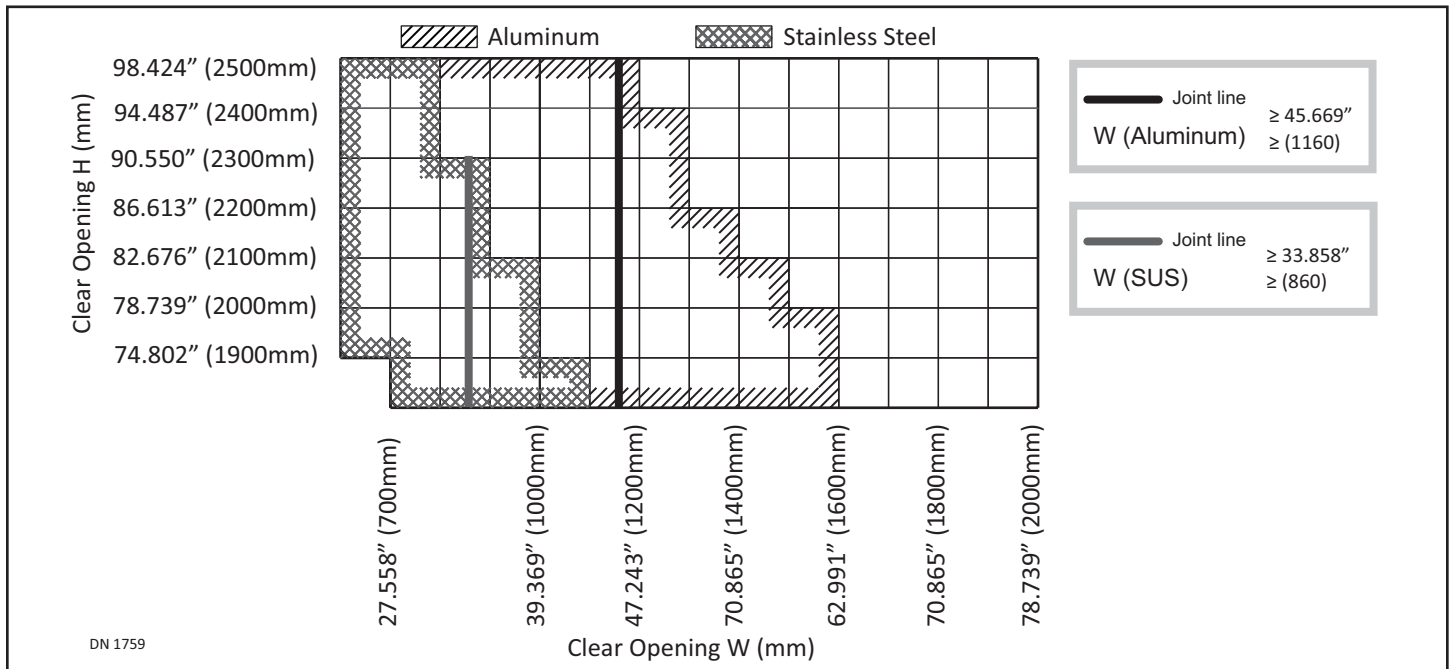

4.6.5 NAX-SG

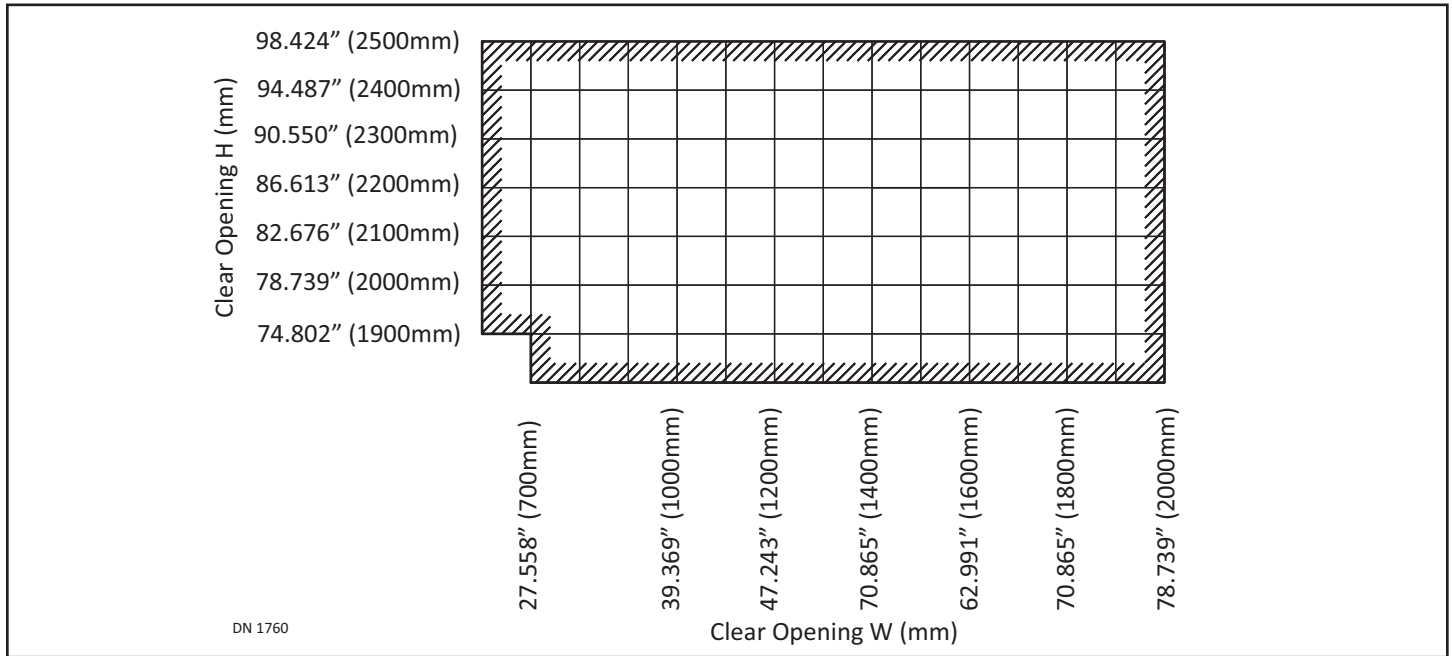

CHAPTER 5: PREPARE THE MOUNTING SURFACE (OR FRAME)

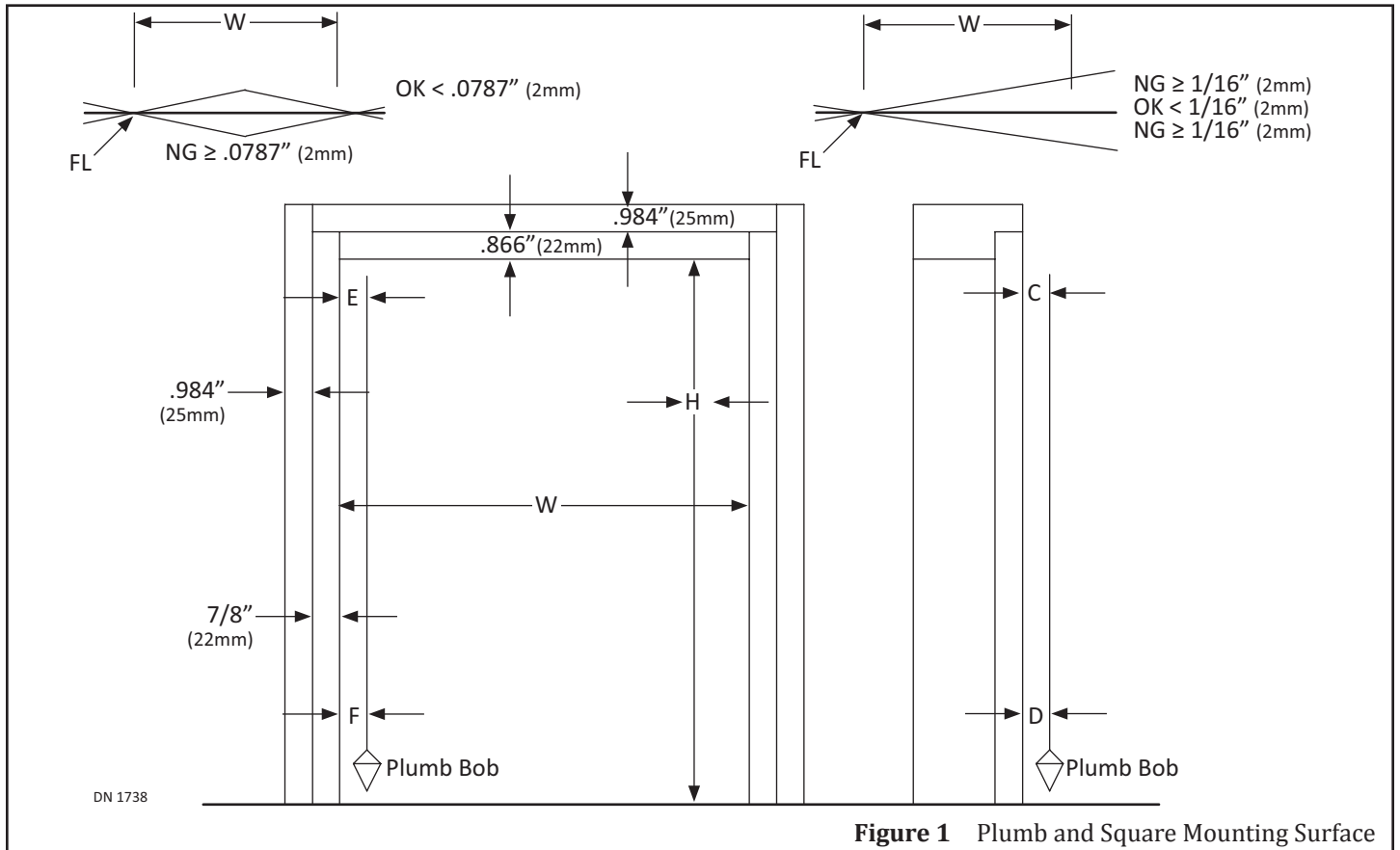

Figure 1 Plumb and Square Mounting Surface

FL	Floor	E	Front/Top of Finished Opening	D	Side/Bottom of Finished Opening
OK	Good	F	Front/Bottom of Finished Opening	W	Width
NG	Not Good	C	Side/Top of Finished Opening	L	Length

SECTION 5.1: Ensure the Finished Opening is Plumb and Square

1. Ensure the Floor is level. There is no real tolerance (< 1/1000mm) for unlevel floors.
2. Go Inside the Finished Opening. Use a Plumb Bob to ensure the Finished Opening is Plumb and Square. Please refer to Figure 1 and Table 1.
3. Go Outside the Finished Opening. Use a Plumb Bob to ensure the Finished Opening is Plumb and Square. Please refer to Figure 1 and Table 1.

Table 1 Plumb/Square Chart

Point of Measurement		Allowable Error
Right side of Opening	C	C and D must be within ± .0787" (± 2mm)
	D	
	E	E and F must be within ± .0787" (± 2mm)
	F	
Left side of Opening	C	C and D must be within ± .0787" (± 2mm)
	D	
	E	E and F must be within ± .0787" (± 2mm)
	F	

SECTION 5.2: Measure Inside the Finished Opening

1. Go inside the Finished Opening.
2. Measure the Width of the Mounting Opening at the Left side, Middle, and Right side. Please refer to Figure 1 and Table 2.
3. Measure the Height of the Mounting Opening at the Top, Middle, and Bottom. Please refer to Figure 1 and Table 2.

Table 2 Measurement Chart

Point of Measurement		Allowable Error
W	Top	Must be within ± .0393" (± 1mm) standard dimensions
	Middle	
	Bottom	
H	Left	Must be within ± .0787" (± 2mm) standard dimensions
	Middle	
	Right	

CHAPTER 6: INSTALL THE JAMB TUBES

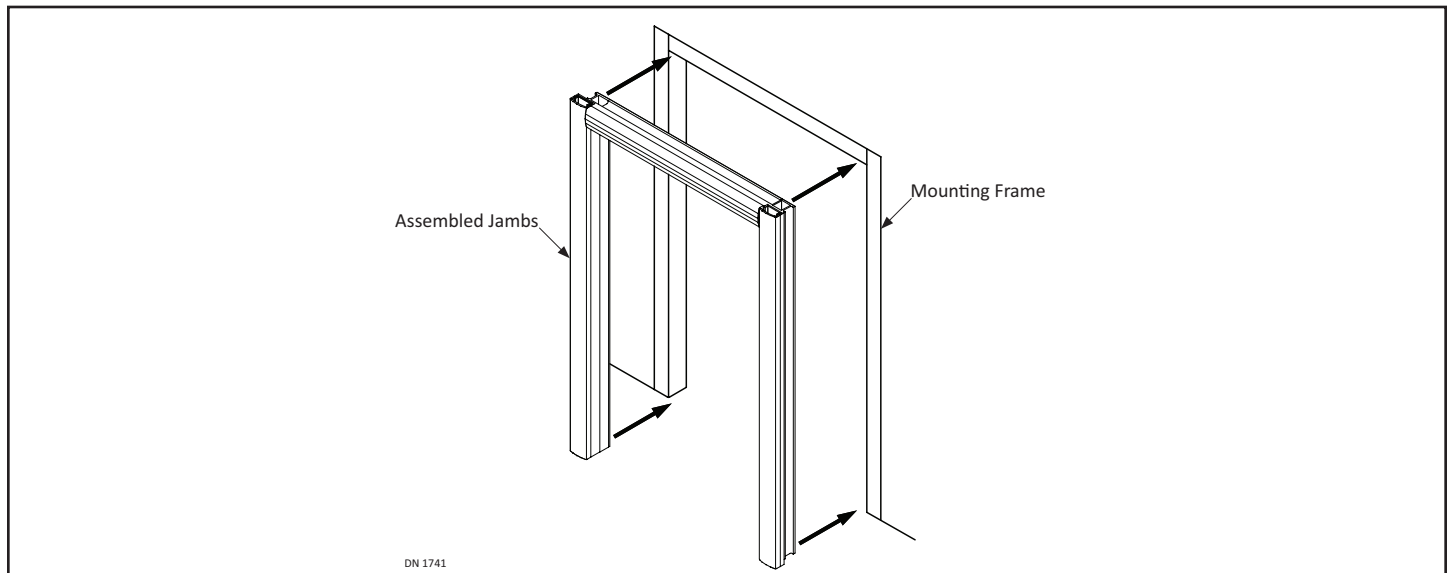

DN 1741

Attention: NABCO recommends that an aluminum frame should be installed within the Finished Opening for the Jamb Tubes to secure to.

Each Jamb Tube is shipped from the NABCO Factory as a set of (3) pieces. (2) Vertical Jamb Tubes and (1) Horizontal Jamb Tube. Each Jamb Tube is cut at the NABCO Factory to be 2 inches (50mm) longer than the actual size needed. The Installer must cut each Jamb Tube to the actual size deemed necessary "on site". NABCO does not provide any cutting tools.

SECTION 6.1: Install Vertical Jamb Tubes

1. Place (1) Channel Cover inside each Vertical Jamb Tube.
2. Cut the Bottom of each Vertical Jamb Tube according to the following: Full Height of Finished Opening + 1/4 inch (7mm).
 - a. Do Not shorten the Vertical Jamb Tubes at the top.
 - b. The 1/4 inch Notch located at the top is necessary for proper installation.
1. Remove Channel Covers from all (3) Jamb Tubes.
2. Butt the notched side of each Jamb Tube against the face of the Mounting Surface. Use the Jamb Tube as a template to mark the pre-drilled holes. NABCO recommends using a punch.
3. Drill screw holes for M4x10 Pan Head screws.
4. Secure each Jamb Tube to the Mounting Surface with M4x10 Pan Head screws.
5. Secure the Channel Cover to each Jamb Tube with M4x20, D6 Countersunk Head screws through pre-drilled holes.

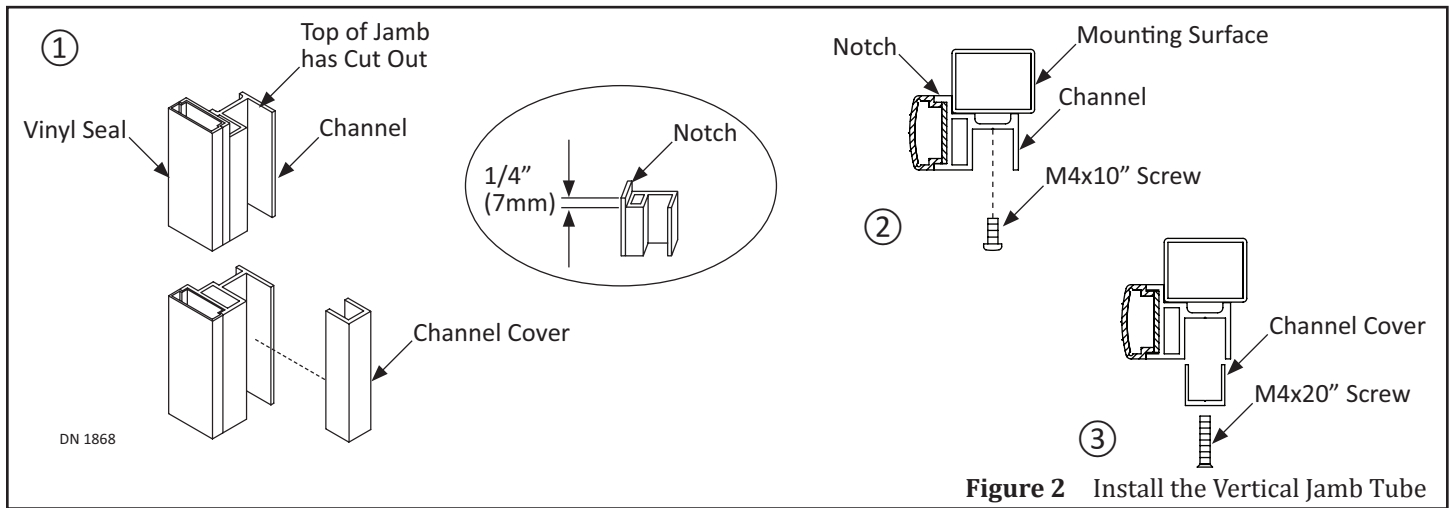

Figure 2 Install the Vertical Jamb Tube

SECTION 6.2: Install Horizontal Jamb Tube

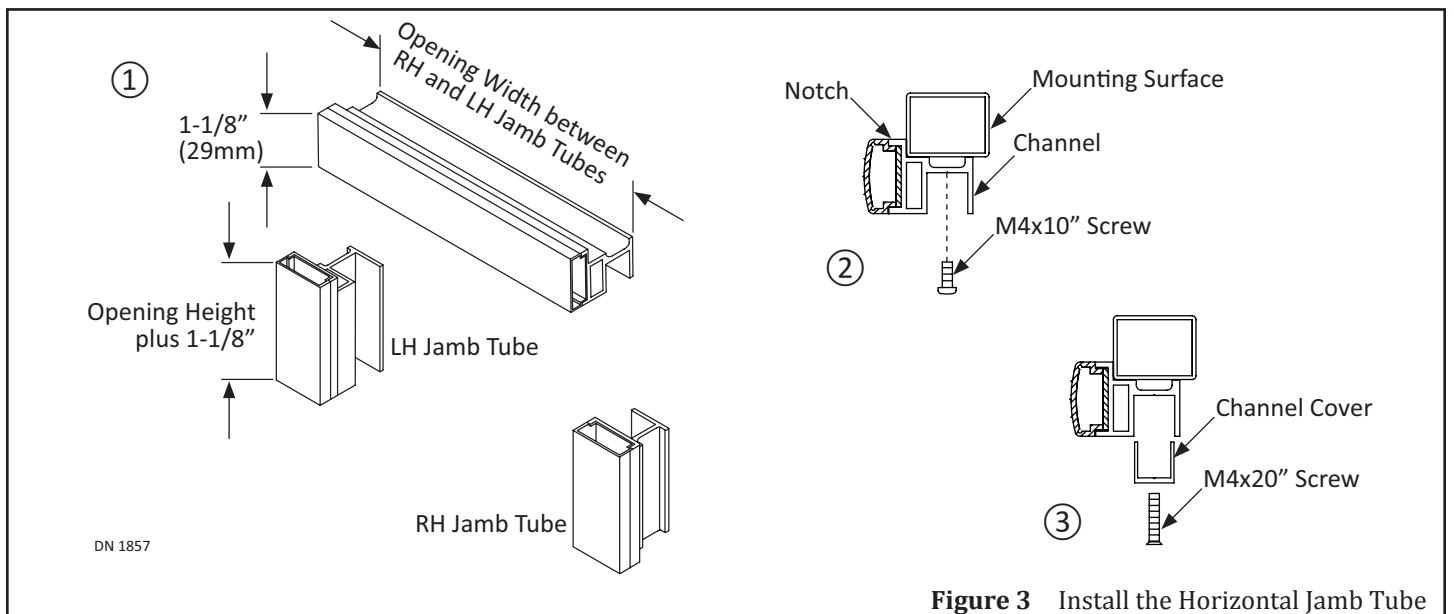

Figure 3 Install the Horizontal Jamb Tube

1. Place (1) Channel Cover inside the Horizontal Jamb Tube.
2. Cut the Horizontal Jamb Tube according to the following: Full Width of Clear Opening (between Vertical Jamb Tubes).
 - a. If the opening width is more than 98.424 inches (2500mm), the Horizontal Jamb tube must be divided into two pieces.
1. Remove Channel Covers from all (3) Jamb Tubes.
2. Butt the notched side of each Jamb Tube against the face of the Mounting Surface. Use the Jamb Tube as a template to mark the pre-drilled holes. NABCO recommends using a punch.
3. Drill screw holes for M4x10 Pan Head screws.
4. Secure each Jamb Tube to the Mounting Surface with M4x10 Pan Head screws.
5. Secure the Channel Cover to each Jamb Tube with M4x20, D6 Countersunk Head screws through pre-drilled holes.

CHAPTER 7: PREPARE THE HEADER

SECTION 7.1: Drill (1) Access Hole for 120 VAC Wiring and Holding Beam Wire(s)

Note: (1) Holding Beam Wire is also inserted through this Access Hole.

1. Go to the Back of Header:
 - ▶ Right Hand Door: Trail End
 - ▶ Left Hand Door: Strike End
2. Measure down (0.551 inch (14mm)) to locate the Top V-Groove.
3. From the back edge of Header measure 3.936" (100mm) towards the center.
4. Drill (1) .875 inch (22.225mm) Access Hole in the V-Groove at the 3.936" (100mm) measurement.

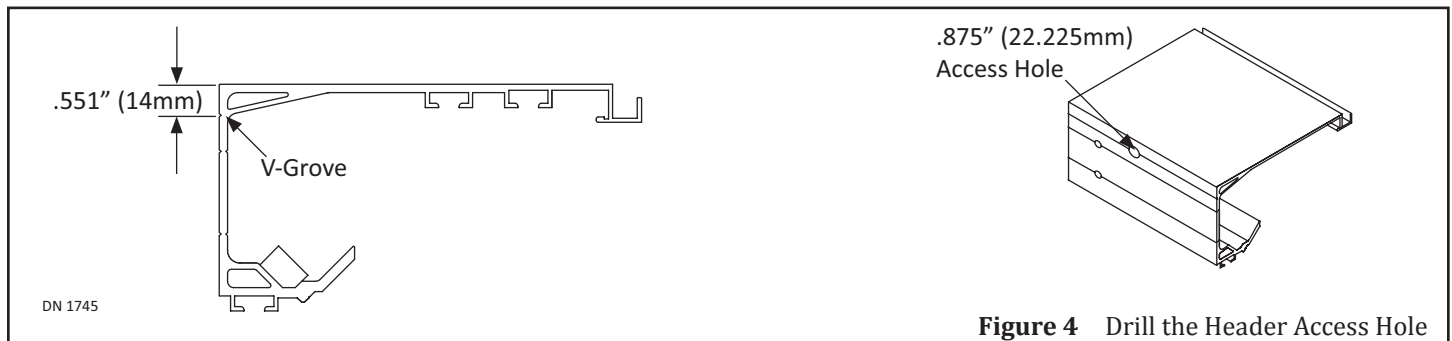

Figure 4 Drill the Header Access Hole

SECTION 7.2: Drill (1) Access Hole for other Holding Beam Wire(s)

1. Go to the Back of Header:
 - ▶ Right Hand Door: Strike End
 - ▶ Left Hand Door: Trail End
2. Measure down (0.551 inch (14mm)) to locate the Top V-Groove.
3. From the back edge of Header measure 3.936" (100mm) towards the center.
4. Drill (1) .875 inch (22.225mm) Access Hole in the V-Groove at the 3.936" (100mm) measurement.

SECTION 7.3: Drill Anchor Holes

- ▶ Anchors are not provided by NABCO.
 - ▶ Anchor holes must be drilled inside V-Grooves located on back of Header only.
 - ▶ The recommended diameter Anchor Hole should be for a 5/16" Hex Washer Head fastener.
 - ▶ Anchors must be appropriate for the type of structure being fastened to. For example: Riv Nuts for Sheet Metal.
1. Place the Header on a flat surface. Protect Header from scratches.
 2. Go to the back of Header. From the Bottom edge towards the top, measure up:
 - ▶ (1.181 inches (30mm)) to locate the bottom V-Groove.
 - ▶ (2.755 inches (70mm)) to locate the middle V-Groove.

3. Drill Anchor Holes in both V-Grooves according to the recommended dimensions:
 - ▶ 1.968 inches or less (<50mm) at each end.
 - ▶ 23.621 inches or less (<600mm) going towards center.
 - ▶ 48 inches or less (<1200mm) on center.

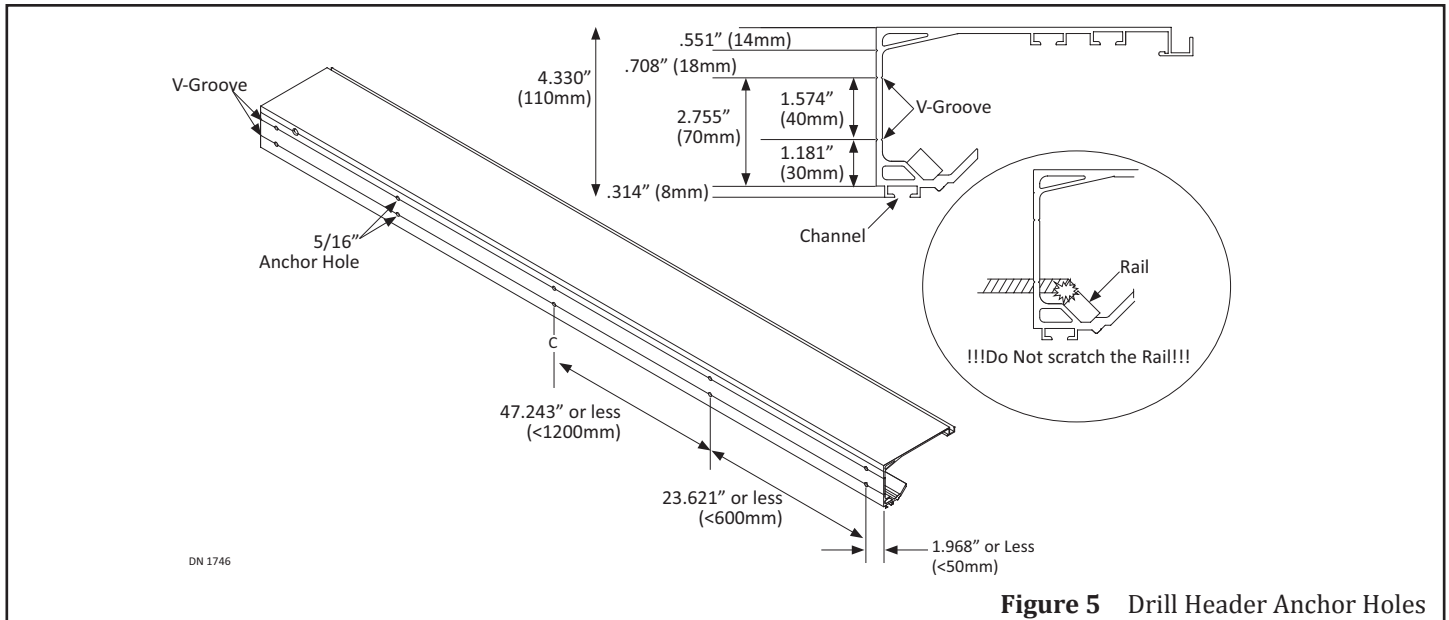

Figure 5 Drill Header Anchor Holes

SECTION 7.4: Drill Cover Screw Holes

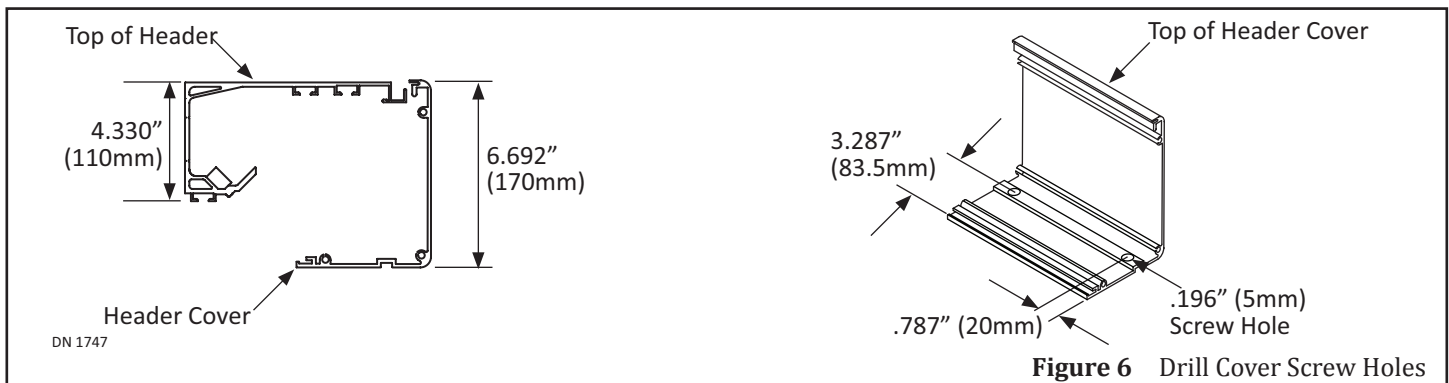

Figure 6 Drill Cover Screw Holes

1. Place the Header Cover on a flat surface. Protect Cover from scratches.
2. From the bottom edge towards the top, measure 3.287 inches (83.5mm).
 - a. Measurement should be in the center of an indent, that spans across the length of Cover.
3. From each end of Cover towards the center, measure .787 inches (20mm).
4. From each end of Cover, drill (1) .196 (5mm) screw hole in the indent at the .787" (20mm) measurement.

CHAPTER 8: INSTALL THE HEADER

SECTION 8.1: Determine Bottom of Header Horizontal Position

1. Measure the full height of the Door. Add 1.69 inches (43mm) to the Door measurement.
2. Measure (Height of door + 1.69 inches) from the floor, upwards and past the top of the Clear Opening.
3. Mark that measurement with a horizontal line across the full width of the Finished Opening, and on the:
 - ▶ Strike side of mounting surface, approximately 7 inches
 - ▶ Trail side of mounting surface, approximately the full width of the Door.

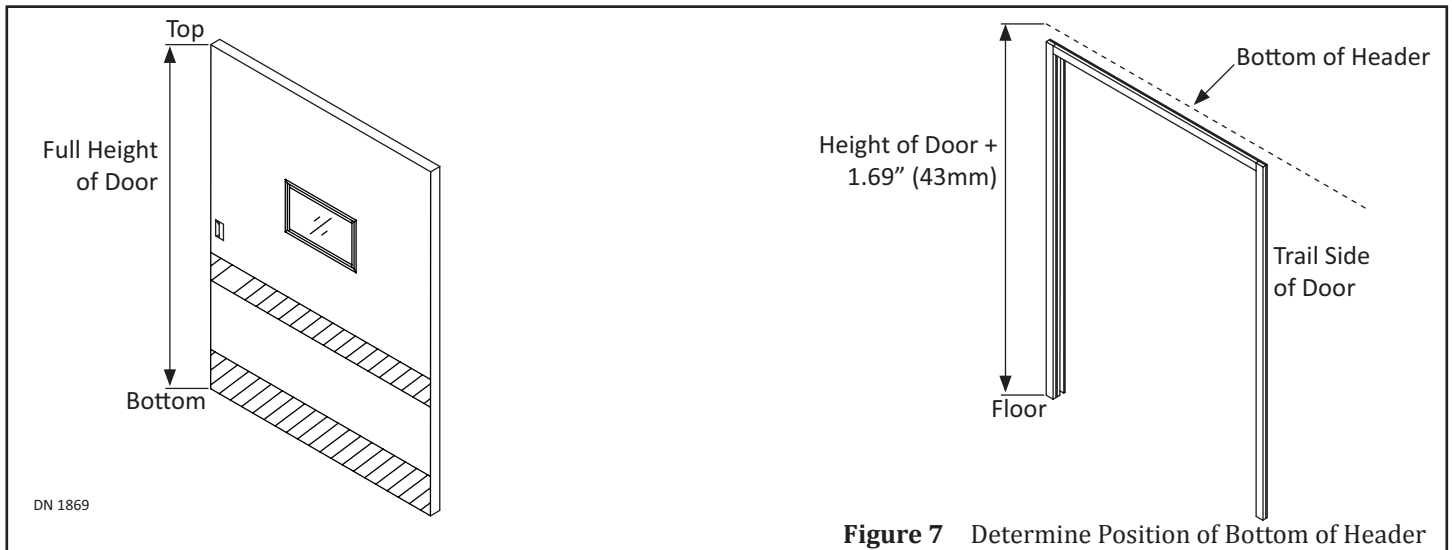

Figure 7 Determine Position of Bottom of Header

SECTION 8.2: Determine Top of Header Horizontal Position

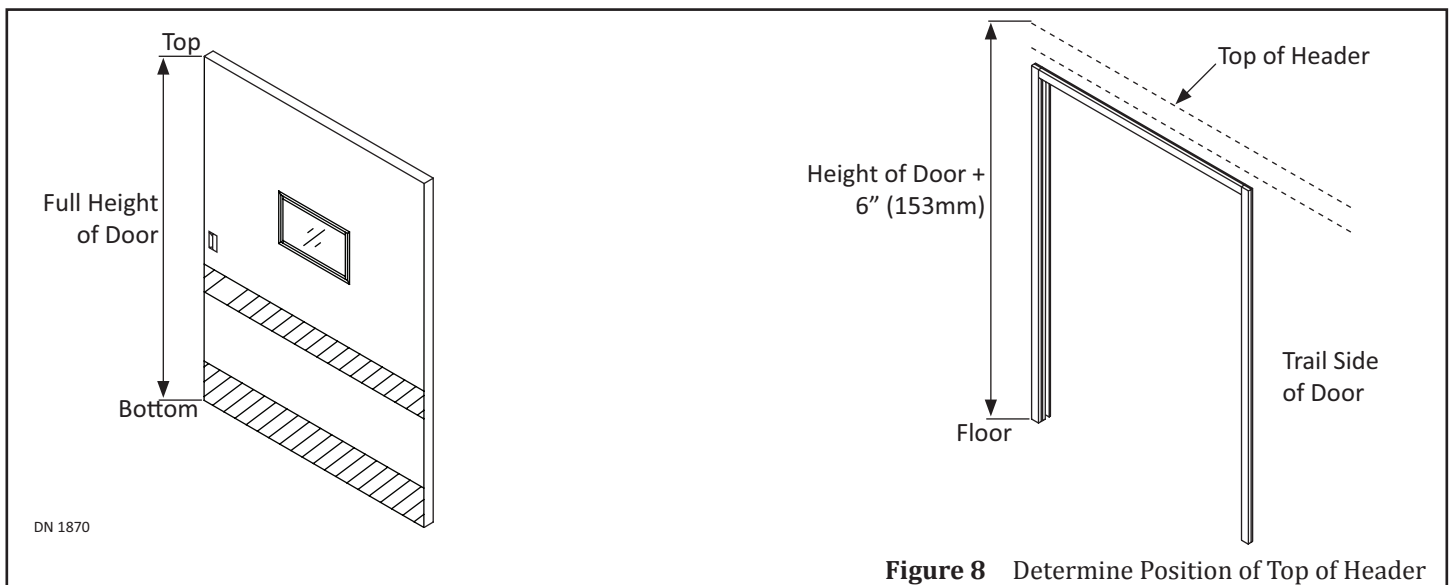

Figure 8 Determine Position of Top of Header

Note: Header height is 4.330 inches (110mm). Header Cover height is 6.692 inches (170mm).

1. Measure (Full Height of the Door + 6 inches (153mm)).
2. From the floor, measure (Height of door + 6 inches) upwards and past the top of the Clear Opening. Mark that measurement on the Mounting Surface with a horizontal line.

SECTION 8.3: Determine Strike Side of Header Vertical Position

1. Go to the Strike Jamb Tube.
2. Measure from the inside edge of Jamb Tube - out - onto the Mounting Surface:
 - ▶ SN & SG = 6 inches (152.5mm)
 - ▶ SX = 9 inches (230mm)
3. Mark that measurement with a Vertical Line across the Horizontal lines.
4. Butt the Bottom of Header up against the Horizontal line. At the same time, butt the Strike side of Header to the Vertical Line.
5. Ensure the Header is square and level. Use shims where deemed necessary.
 - a. If not, the Header may cause abnormal sound and/or decrease service life and/or Front Cover not to install properly.

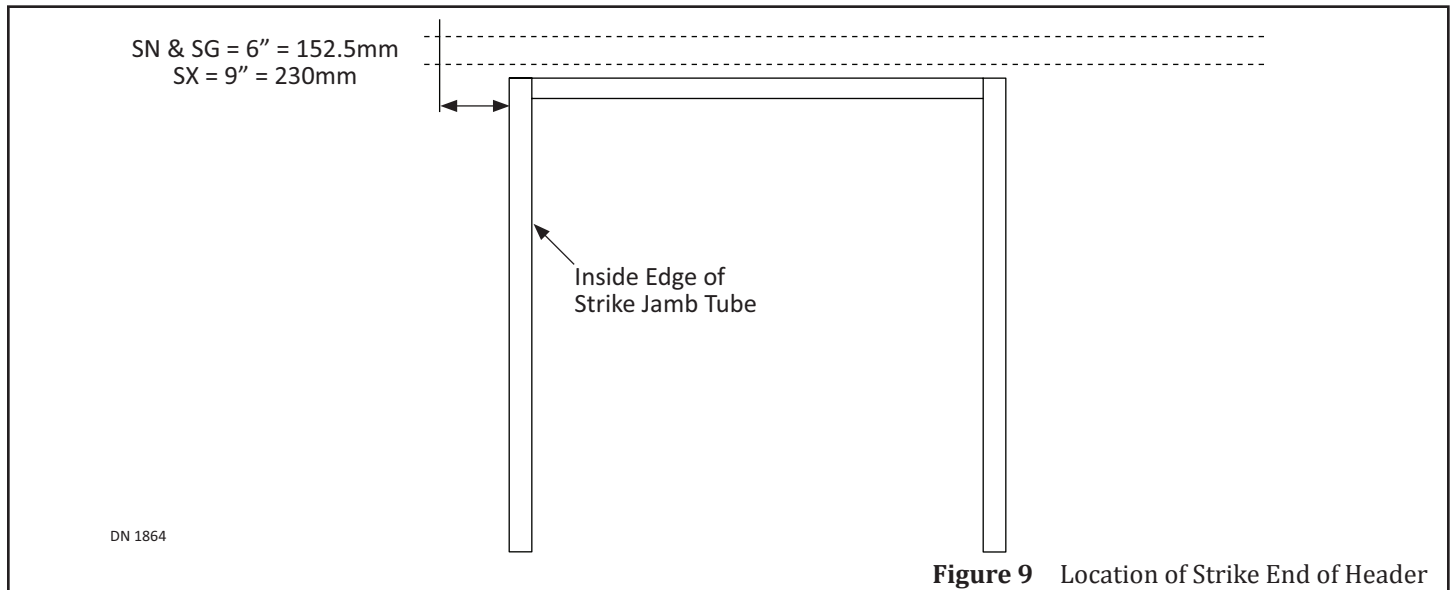

6. Secure the Header to the Mounting Surface with anchors that are appropriate for the type of structure being fastened to.
 - a. If anchoring the Header to:
 - ▶ Sheet Metal: it is recommended to install Riv Nuts into the Mounting Surface, then use 5/16" (Mx16) Hexagon Head Bolts and 5/16" Washers.
 - ▶ Studs: it is recommended to use Lag Bolts.

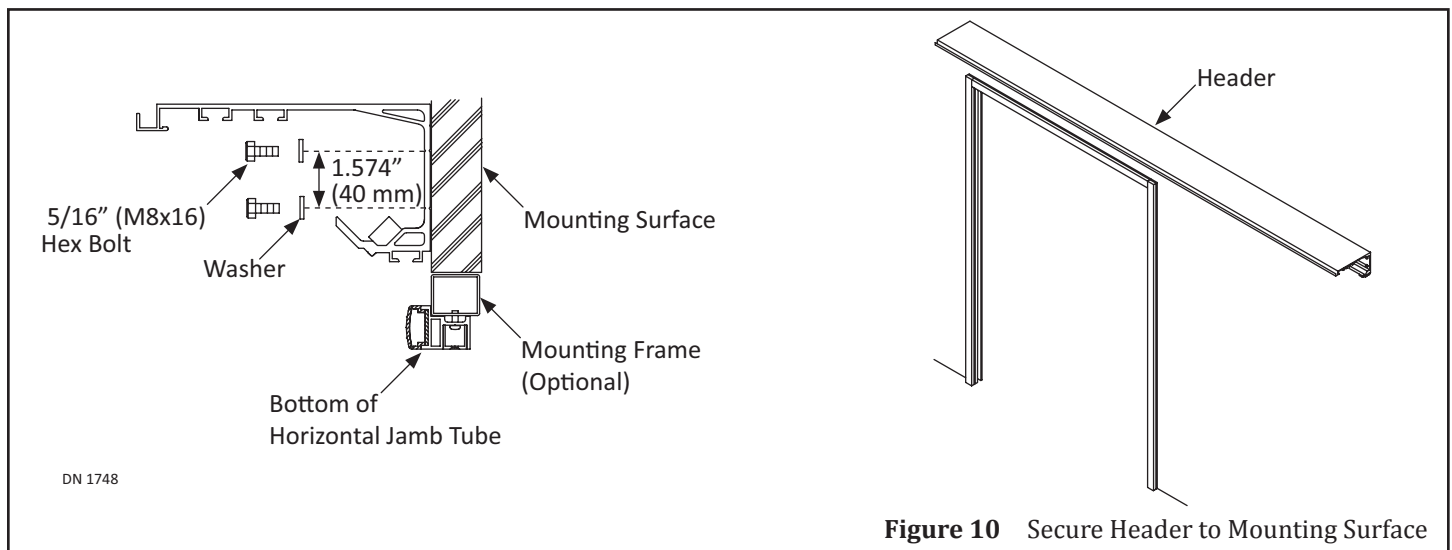

CHAPTER 9: INSTALL THE HOLDING BEAMS

In the event a pedestrian or object crosses the threshold, the:

1. Holding Beam is broken.
2. Holding Beam Controller is utilized to send a signal to the U30 Controller.
3. NAX Slide Door automatically stays open until the Threshold is clear.

SECTION 9.1: Insert Holding Beams within Channels

1. Obtain (2) Channels used to insert inside the Vertical Jamb Tubes.
2. Measure (21 inches) from the bottom of each Channel. Mark and drill (1) Hole.
 - a. If a second set of Holding Beams have been provided, measure an additional (54 inches) from the bottom of each Channel. Mark and drill (1) Hole.
 - b. For detailed information, please refer to C-00198 U30 Electrical Installation Manual (provided within the Decal Packet).

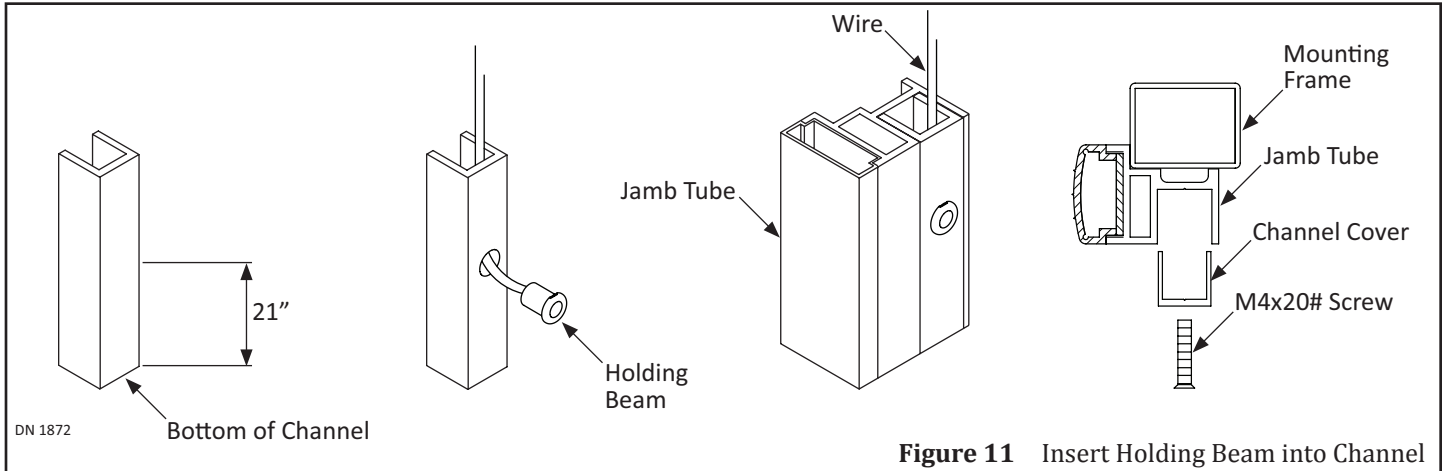

Figure 11 Insert Holding Beam into Channel

3. Insert (1) Holding Beam into each hole until it is flush. At the same time, run the wiring "up and out" the top of each Channel.
4. Secure each Channel to the Vertical Jamb Tubes with M4x20# Screws.
 - a. Ensure the excess wiring is pulled out of the Channel (at the top).

SECTION 9.2: Wire the Holding Beams to the Holding Beam Controller

1. Drill an Access Hole through the Mounting Surface on the Strike Side and the Trail Side of the Clear Opening.
2. Run the wiring for each Holding Beam through the Access Hole, and then into the Header Access Hole.
3. For detailed wiring instructions, go to the U30 Electrical Installation Manual, P/N C-00198 (provided within the Decal Packet).

CHAPTER 10: INSTALL SLIDE BOLTS INTO HEADER

Attention: Do Not insert Slide Bolts on a Slanted angle. Doing so may cause damage to the Header.

1. Insert Slide Bolts into Header according to the Table listed below.

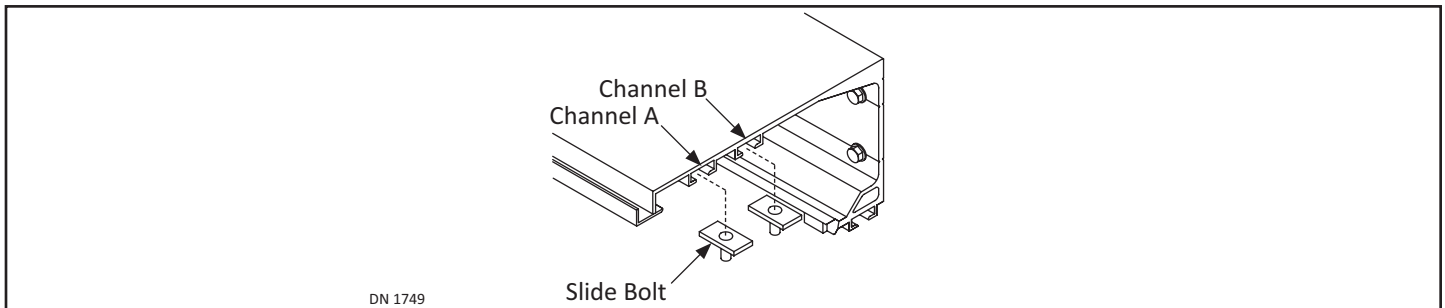

Component	Brackets	Channel	Component	Brackets	Channel
Motor/Operator	2	A	Sensor Beam Controller (Option)	2	A
Controller	2		Front Cover Bracket	2	
Idler Pulley	2		Door Stop	4	B
Spring Mechanism Receiver	2		Wire Clip (not a Slide Bolt)	3	A
Power Supply	2		Slide Bolt Total: Channel A (14) Channel B (4)		

CHAPTER 11: INSTALL THE DOOR STOPS

Attention: Do Not tighten M6 Washer Nuts on a Slanted angle. Doing so may cause damage to the Header.

Note: It is recommended to install Door Stops first. If not, the installation process will prove to be too hard.

1. Insert (4) Slide Bolts through Channel B.
 - a. Position (2 of 4) Slide Bolts at the Strike End of Door, and (2 of 4) Slide Bolts at the Trail End of Door.

2. Secure (1) Door Stop to each set of Slide Bolts with (2) M6 Washer Nuts. Loosely tighten.
3. Fully Close the Slide Door. Slide the Strike Door Stop towards the center of Header, until it butts up against the Slide Door.
4. Tighten the M6 Washer Nuts.
5. Fully Open the Slide Door. Slide the Trail Door Stop towards the center of Header, until it butts up against the Slide Door.
6. Tighten the M6 Washer Nuts.

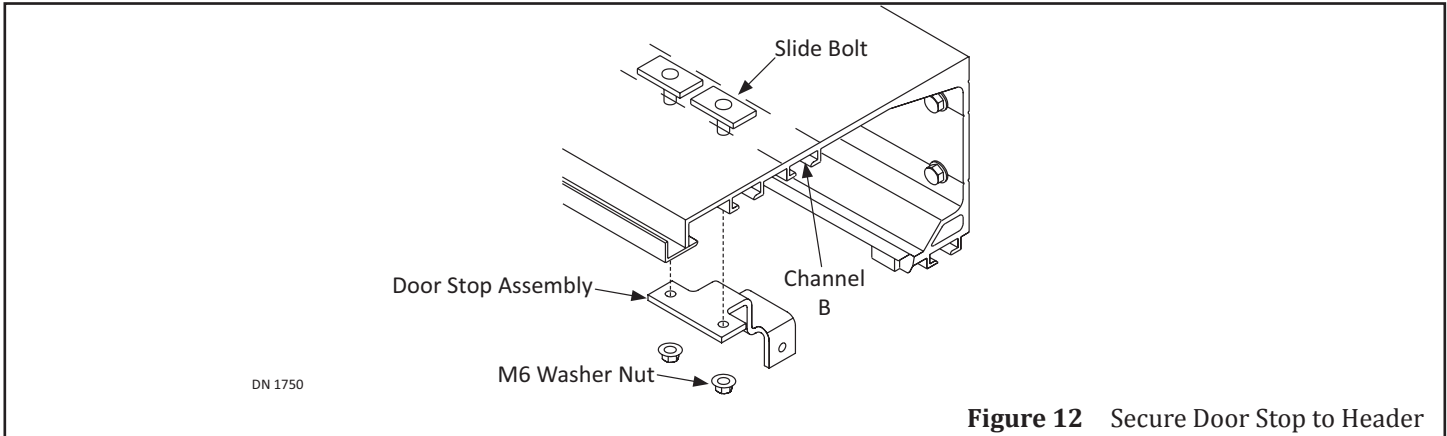

Figure 12 Secure Door Stop to Header

CHAPTER 12: INSTALL THE STRIKE BOTTOM GUIDE

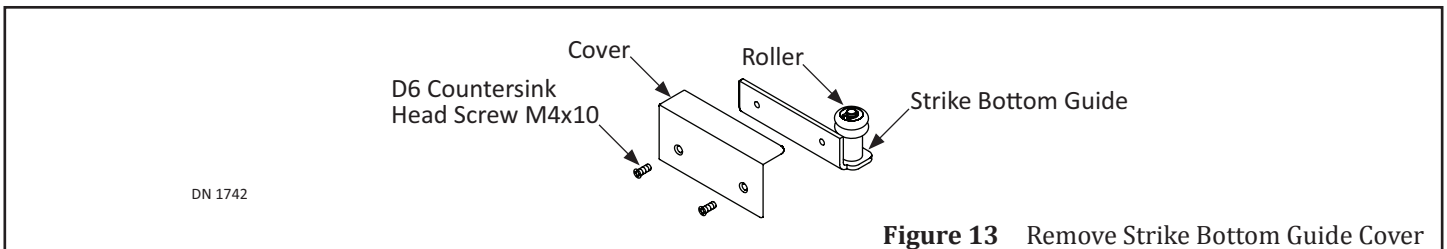

Figure 13 Remove Strike Bottom Guide Cover

1. Obtain the Bottom Guide for the Strike Edge of Door. Remove the Cover.

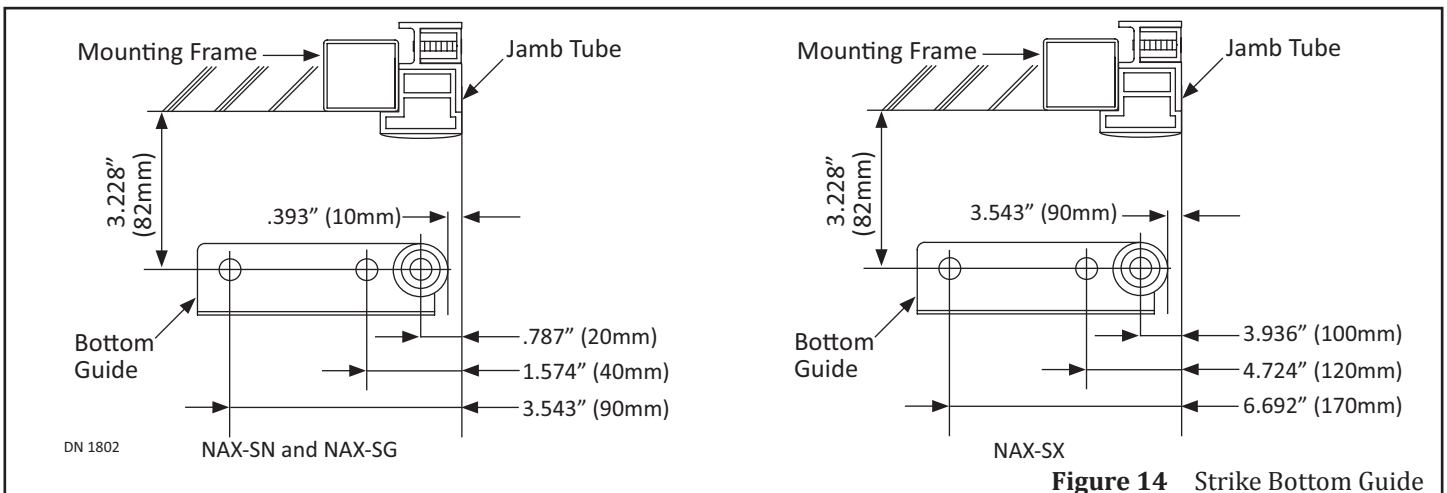
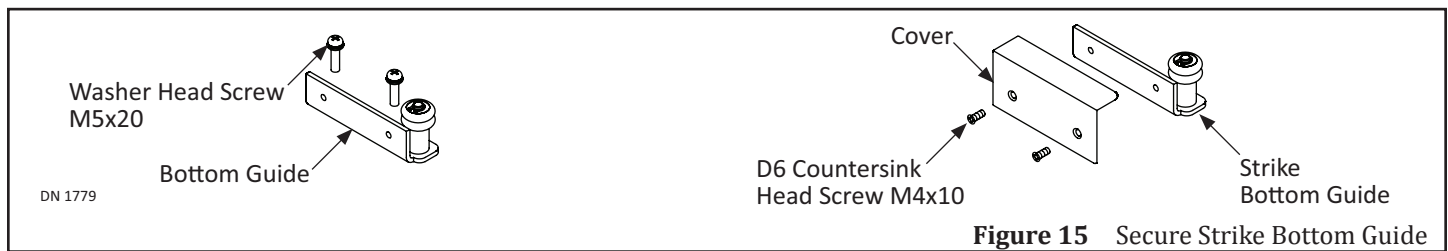

Figure 14 Strike Bottom Guide

2. Go to the face of the Mounting Surface. At a 90 degree angle, measure 3.228 inches (90mm). Mark a Horizontal Line.
3. Go to the edge of the Strike Jamb Tube. Measure towards the Horizontal Line mark:
 - ▶ For NAX-SN and NAX-SG Units: Measure 3.543 inches (90mm).
 - ▶ For NAX-SX Units: Measure 6.692 inches (170mm).
4. Mark a Vertical Line across the Horizontal Line. This is the center of the screw hole (farthest away from the Roller).
5. Center the Bottom Guide's pre-drilled screw hole to the marked screw hole. Ensure the Bottom Guide is square and level.

6. Marked and drill a screw hole. Use the Bottom Guide as a template to mark and drill the second screw hole.
7. Secure the Bottom Guide to the floor with (2) M5x20 Washer Head screws.
8. Replace the Bottom Guide Cover.



CHAPTER 13: INSTALL THE TRAIL BOTTOM GUIDE

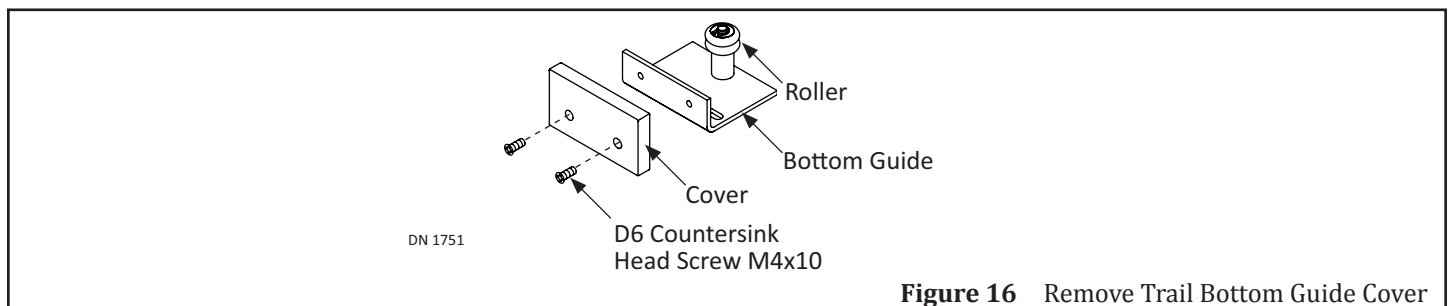

1. Obtain the Bottom Guide for the Trail Edge of Door. Remove the Cover.

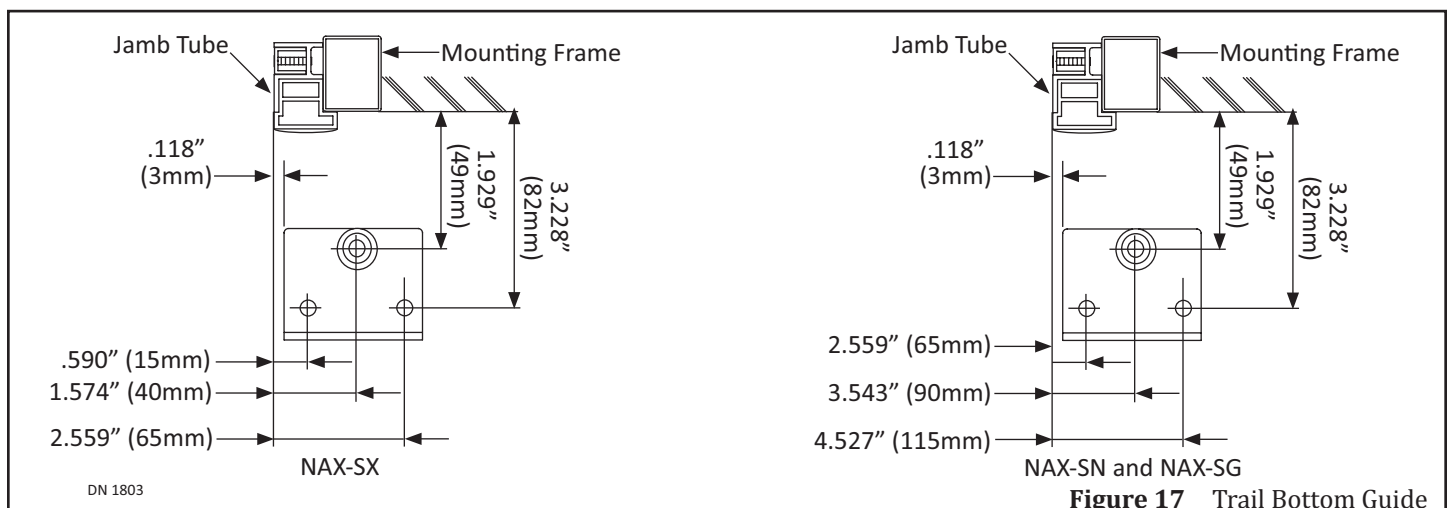

2. Go to the face of the Mounting Surface. At a 90 degree angle, measure 3.288 inches (82mm).
3. Mark a Horizontal Line.
4. Go to the edge of the Trail Jamb Tube.
5. Measure towards the Horizontal Line mark
 - ▶ For NAX-SN and NAX-SG Units: Measure 2.559 inches (65mm) to the Horizontal Line.
 - ▶ For NAX-SX Units: Measure 4.527 inches (115mm) to the Horizontal Line.
6. Mark a Vertical Line across the Horizontal Line. This is the center of screw hole (farthest away from edge of Trail Jamb Tube)
7. Center the Bottom Guide's pre-drilled screw hole to the marked screw hole. Ensure the Bottom Guide is square and level.
8. Marked and drill a screw hole. Use the Bottom Guide as a template to mark and drill the second screw hole.
9. Secure the Bottom Guide to the floor with (2) M5x20 Washer Head screws.
10. Replace the Bottom Guide Cover.

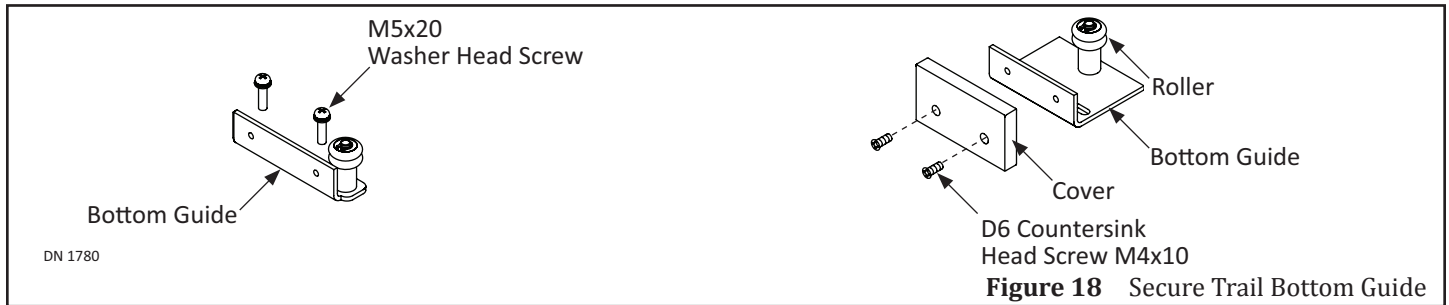

CHAPTER 14: INSTALL THE SLIDE DOOR

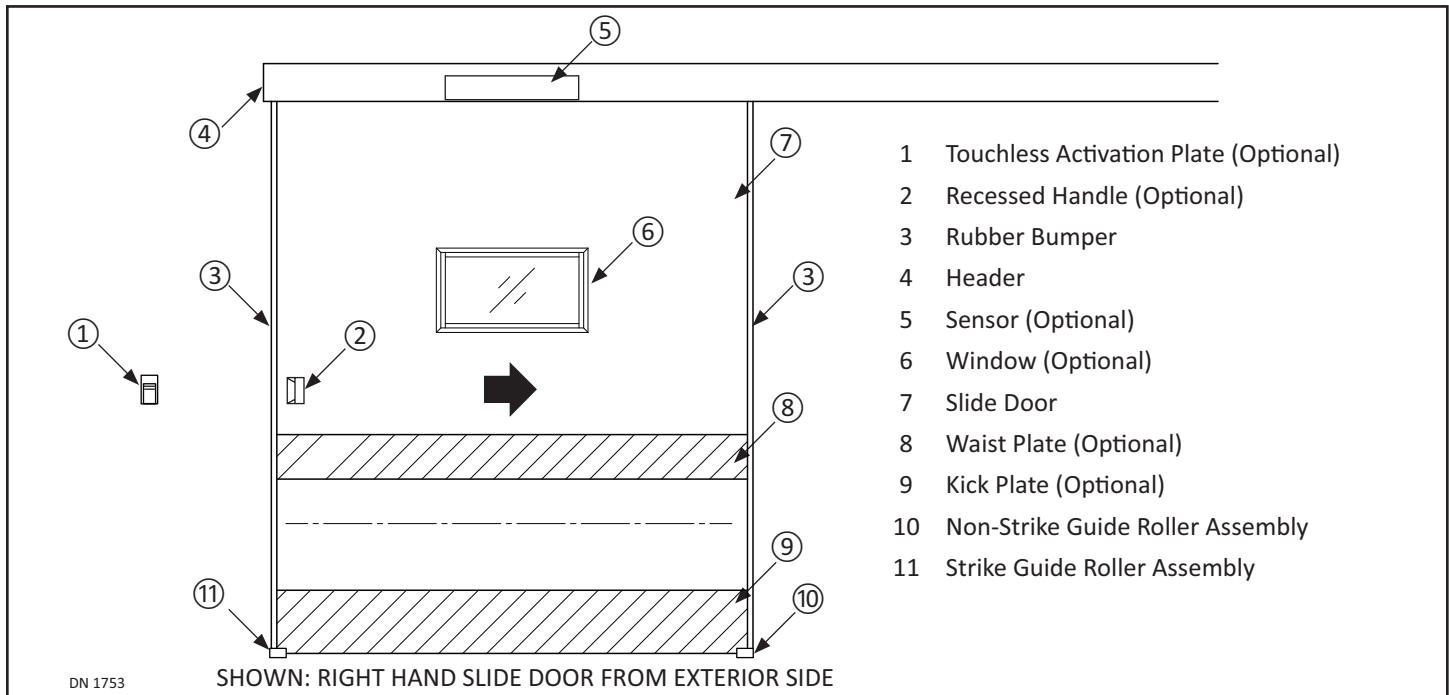

SECTION 14.1: Install the Rubber Bumper

11. Obtain the Rubber Bumper. The full length of the Back Side has Cut Outs to clear Mounting Plates inside each Channel.
12. Cut each Rubber Bumper so it is the same length as each Channel. In doing so, ensure the:
 - ▶ Top of Channel is 0.964" (25.5mm) solid.
 - ▶ Bottom of Channel is 0.905" (23mm) solid.

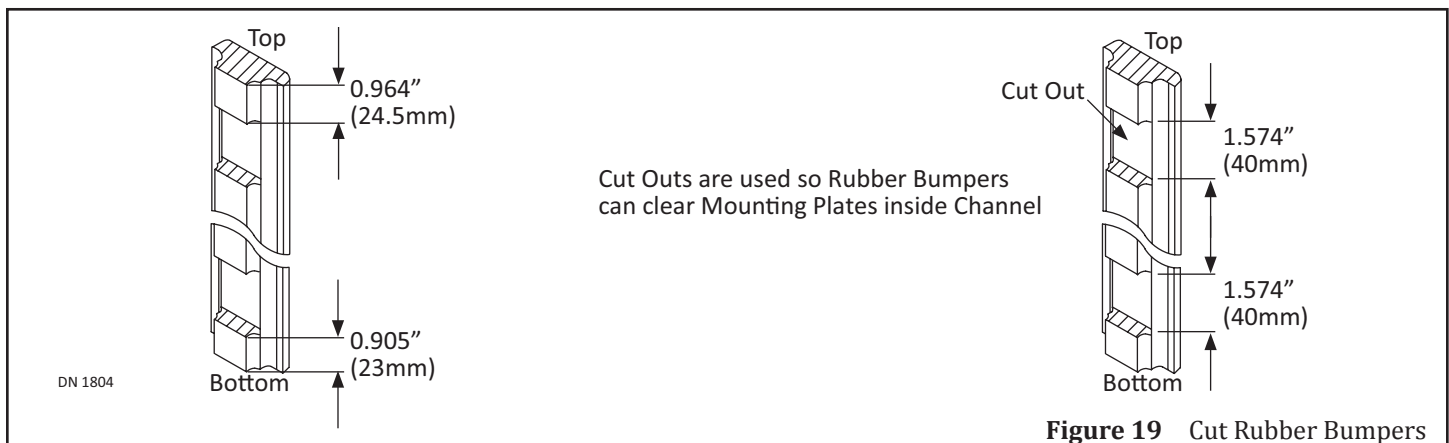

13. Peel off the paper strip to expose the adhesive portion of tape. With the Rounded End on the Exterior side of door, push each Rubber Bumper into each Channel. A flat head screwdriver may help the insertion process.
 - a. Ensure the Rubber Bumper is completely installed with no air pockets, or crimps, etc.

Attention: Insert each Rubber Bumper so the rounded end is on the Exterior side of door. The squared end must always be on the Interior side of door.

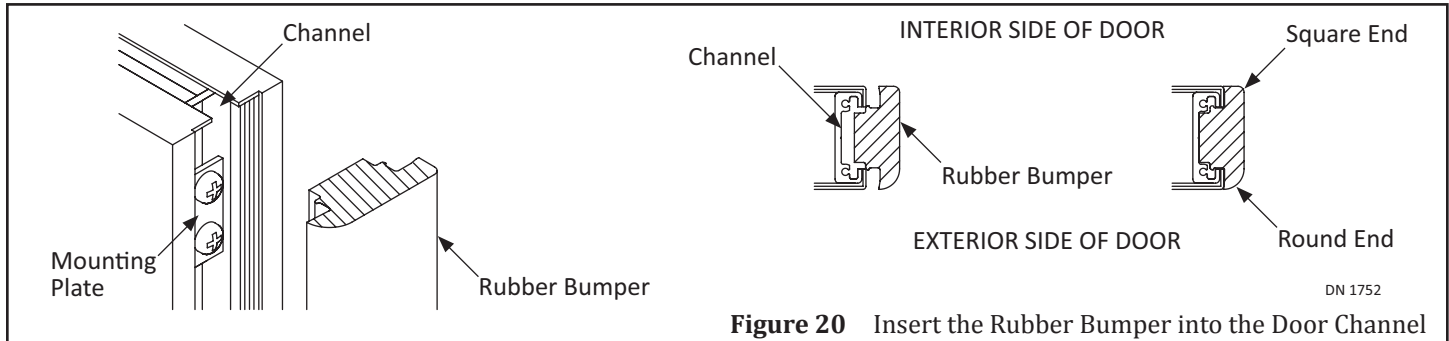

Figure 20 Insert the Rubber Bumper into the Door Channel

SECTION 14.2: Install Roller Carriers

1. Go inside the Top Door Channel. Remove all hardware from each Mounting Plate.
 - a. The Middle Mounting Plate is reserved for the Spring Mechanism.

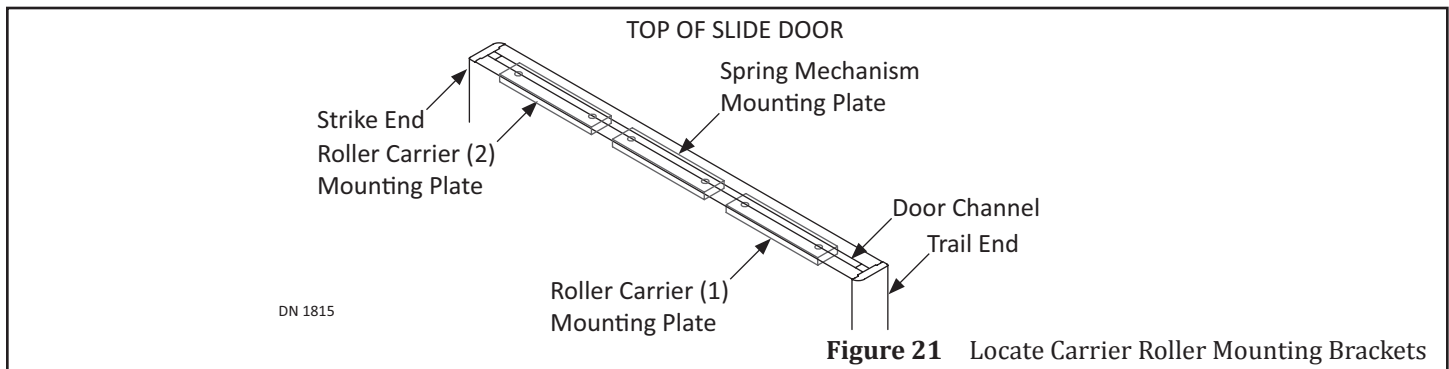

Figure 21 Locate Carrier Roller Mounting Brackets

Attention: If the Roller Carrier is secured to the Door without proper measurements, or tilted/crooked, the Door may not run on the Track correctly, and/or Airtightness performance may fail.

2. Measure for proper position. From the Trail edge of Door, measure towards the center:
 - ▶ NAX-SN, and NAX-SX, and (NAX-SG Units without a handle): 8.267 inches (210mm) and 3.543 inches (90mm).
 - ▶ For NAX-SG Units with a Handle: 10.826" (275mm) and 4.921" (125mm).
3. Slide the Mounting Plate until proper position has been achieved.

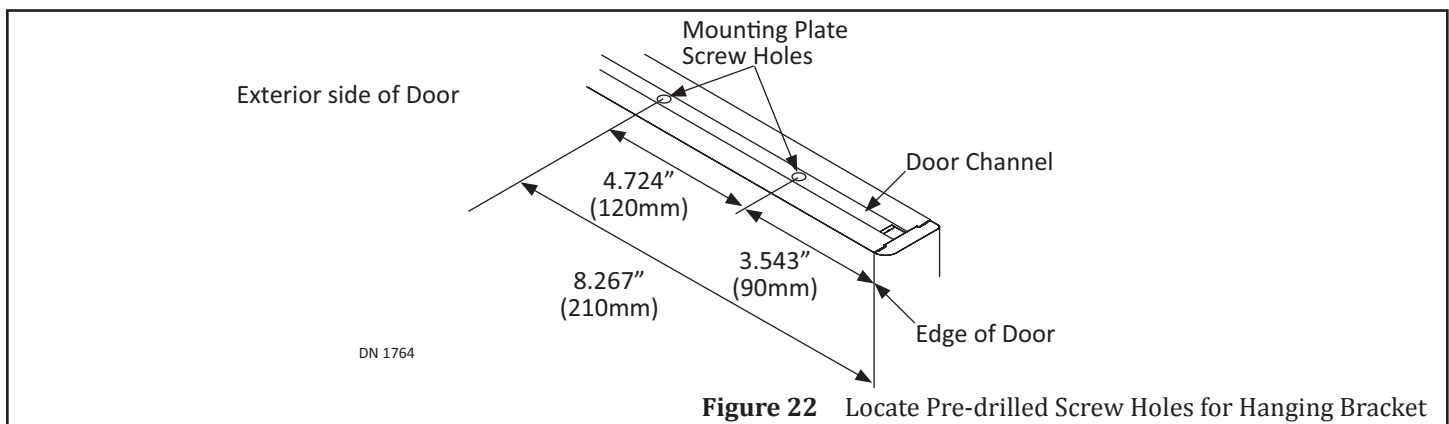
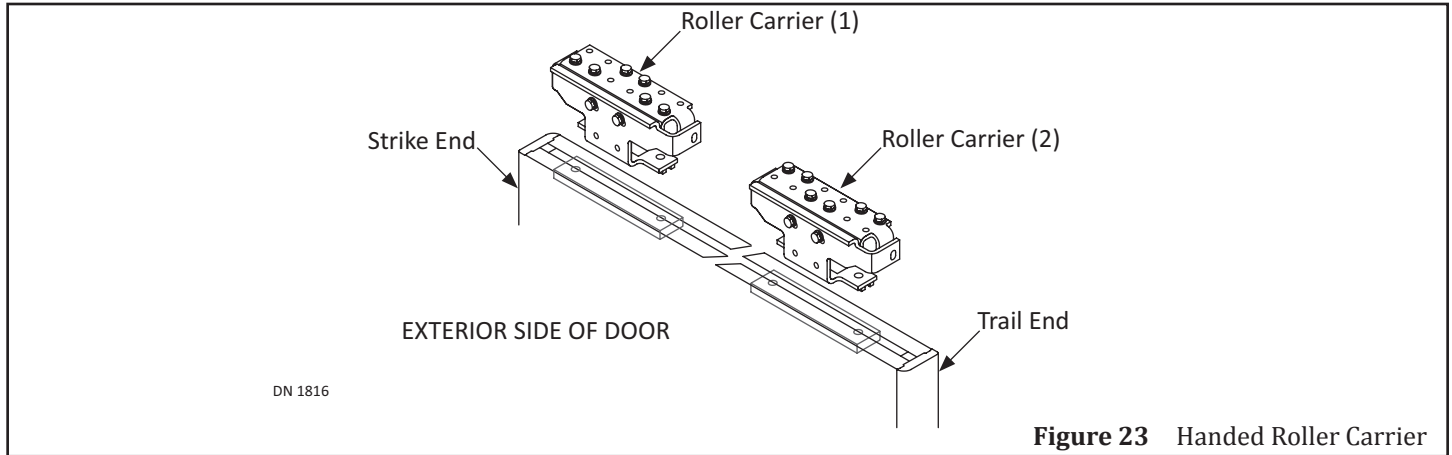

Figure 22 Locate Pre-drilled Screw Holes for Hanging Bracket

Attention: Roller Carriers can be identified with an embossed number on the front plate (1) or (2). Or by the middle Roller secured on the Interior side of Carrier (1), or the Exterior side of Carrier (2). Carrier (1) must always be installed on the Strike Side of Door.

4. Go to the Strike Side of Door. Align Carrier (1) to the Mounting Bracket so the middle Roller faces the interior side of Door.
5. Go to the Trail Side of Door. Align Carrier (2) to the Mounting Bracket so the middle roller faces the exterior side of Door.



6. If deemed necessary, place (1 - 5) Spacers between the Top of Door, and Roller Carrier.
 - a. Spacers are used to lower the Slide Door. (5) Spacers for each Roller Carrier have been provided by NABCO.
7. Ensure each Roller Carrier is square and level.
 1. Go to the side of Carrier. Loosen (1) M8 x30mm Hex Head Bolt, and (1) Washer. This is commonly referred to as the Height Adjustment Bolt.
 2. Go to the front plate of Carrier. Locate and then loosen (2) M8x30mm Hex Head Bolts.
 3. Tilt the Rollers up or down until they are square the level.
8. Secure each Roller Carrier to the Mounting Bracket with (2) M8x30mm Hexagon Head Bolts (2) Springs and (2) Washers.

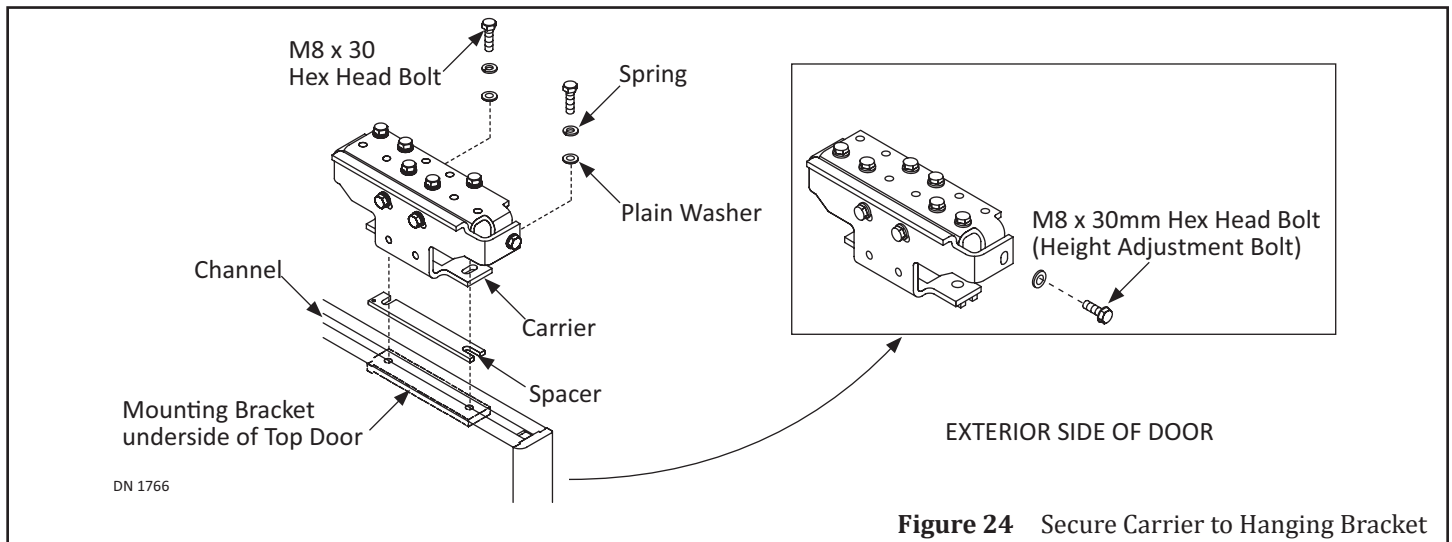

SECTION 14.3: Hang Slide Door onto Header Track

WARNING

Do Not hang or detach Slide Door alone. Always work with another NABCO trained technician. Working alone may result in injury by fallen door.

WARNING

When manually opening and closing the Slide Door; Do Not place Hand inside the Header, or between the Strike end of Door and Jamb Tube. Doing so may injure Hand.

Attention: When hanging the Slide door:

- ▶ **Do Not apply weight to the:**
 - **Vinyl Seal at the bottom. Doing so may cause damage.**
 - **Bottom Guides. Doing so may cause damage.**
- ▶ **Ensure the Slide door is not tilted to either side. It will be too difficult to hang otherwise.**

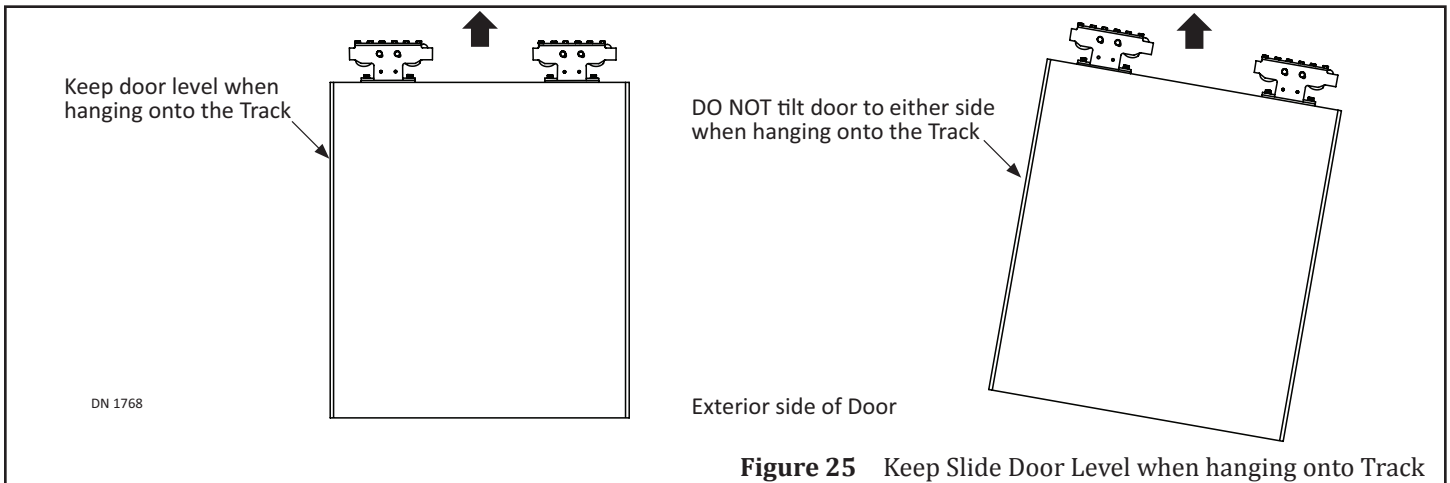

Figure 25 Keep Slide Door Level when hanging onto Track

1. Locate the Vinyl Seal at the bottom of the Slide Door. Turn the Slide Door around so the Vinyl Seal is on the **Interior** side.
2. Tilt the Slide door towards the Exterior to insert the Bottom Guide Roller into the Trail End of Slide Door.

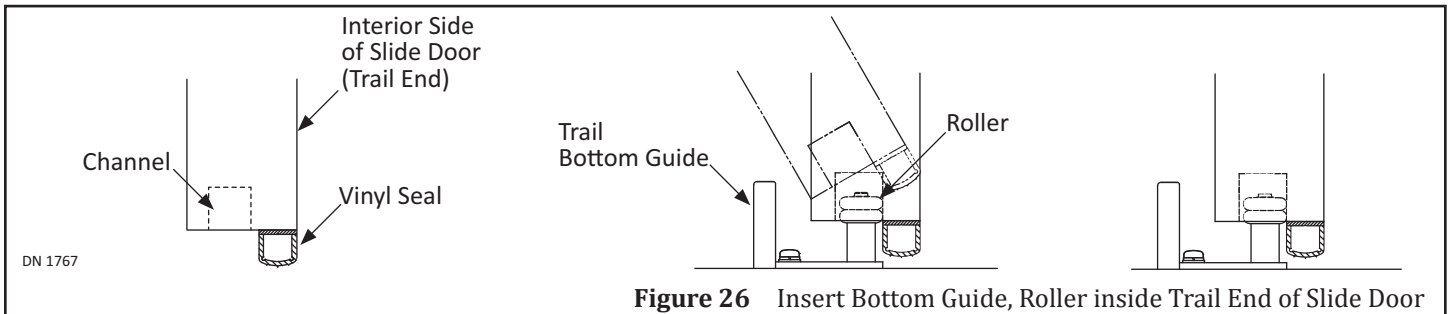

Figure 26 Insert Bottom Guide, Roller inside Trail End of Slide Door

3. At the same time, position the Strike side of Slide Door so the Bottom Guide, Roller can butt up against the Bumper.

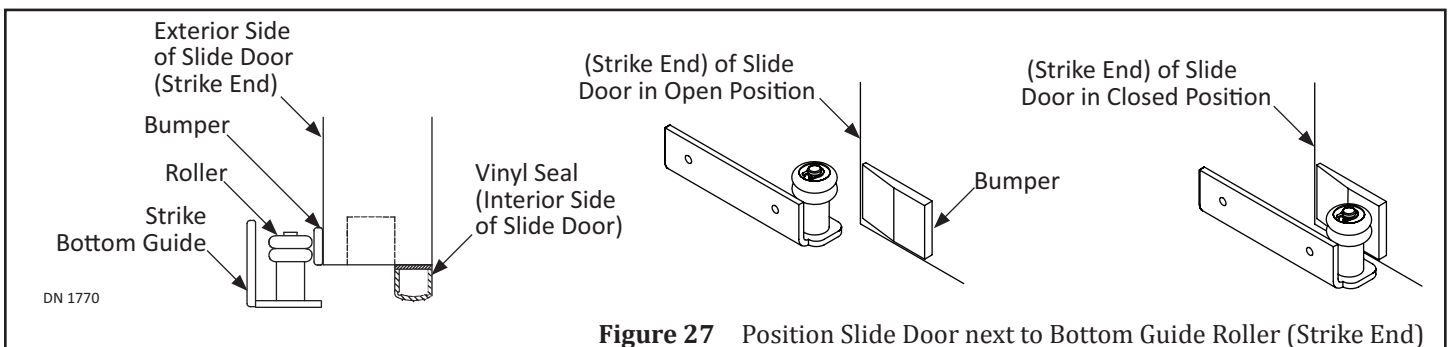

Figure 27 Position Slide Door next to Bottom Guide Roller (Strike End)

4. Lift the door, and place both Carriers onto the Track located inside the Header.

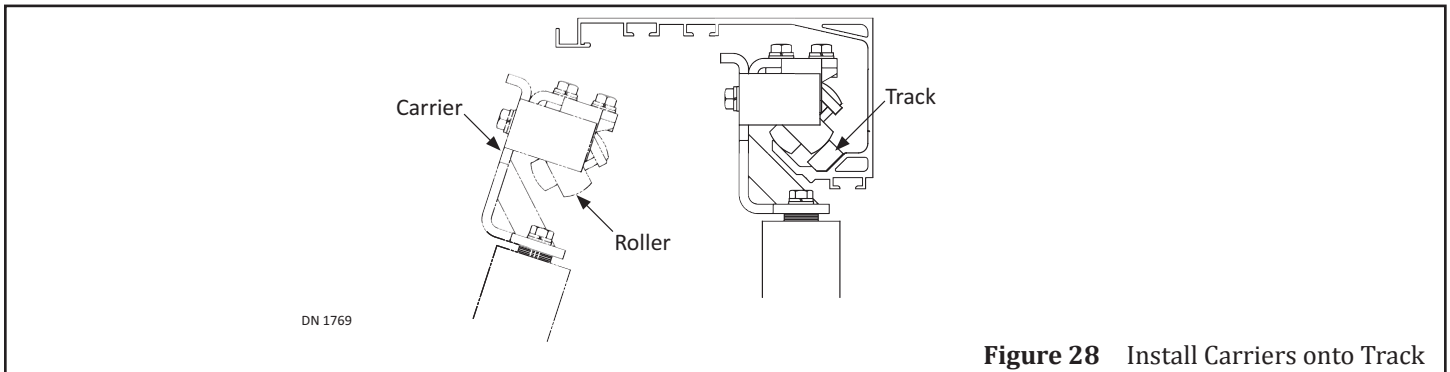

Figure 28 Install Carriers onto Track

SECTION 14.4: Install the Belt Clip

1. From the Exterior side:
 - ▶ Right Hand Door:
 - Secure (1) Belt Clip to the STRIKE Roller Carrier with (2) M8 x 16mm Hex Head Bolts and (2) Spring Washers.
 - ▶ Left Hand Door:
 - Secure (1) Belt Clip to the TRAIL Roller Carrier with (2) M8 x 16mm Hex Head Bolts and (2) Spring Washers.

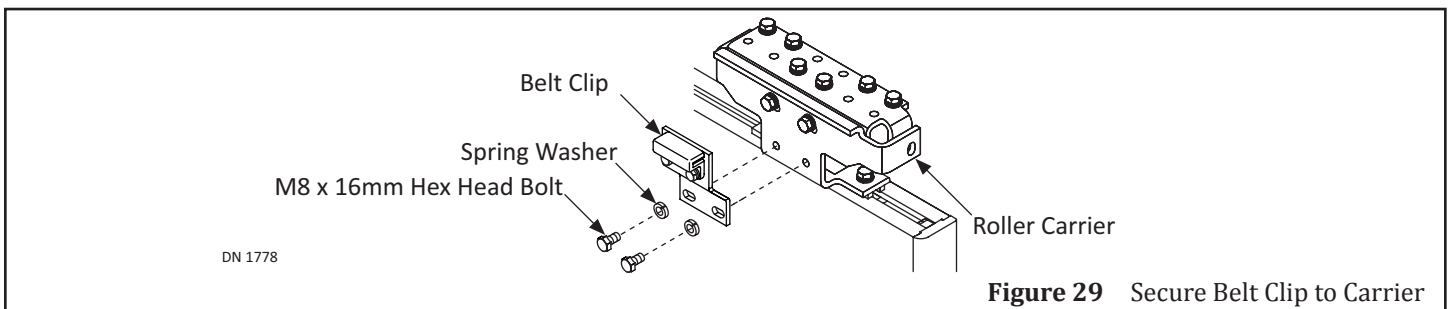

Figure 29 Secure Belt Clip to Carrier

SECTION 14.5: Install the Idler Pulley

Attention: Do Not tighten M6 Washer Nuts on a Slanted angle. Damage to Components may occur.

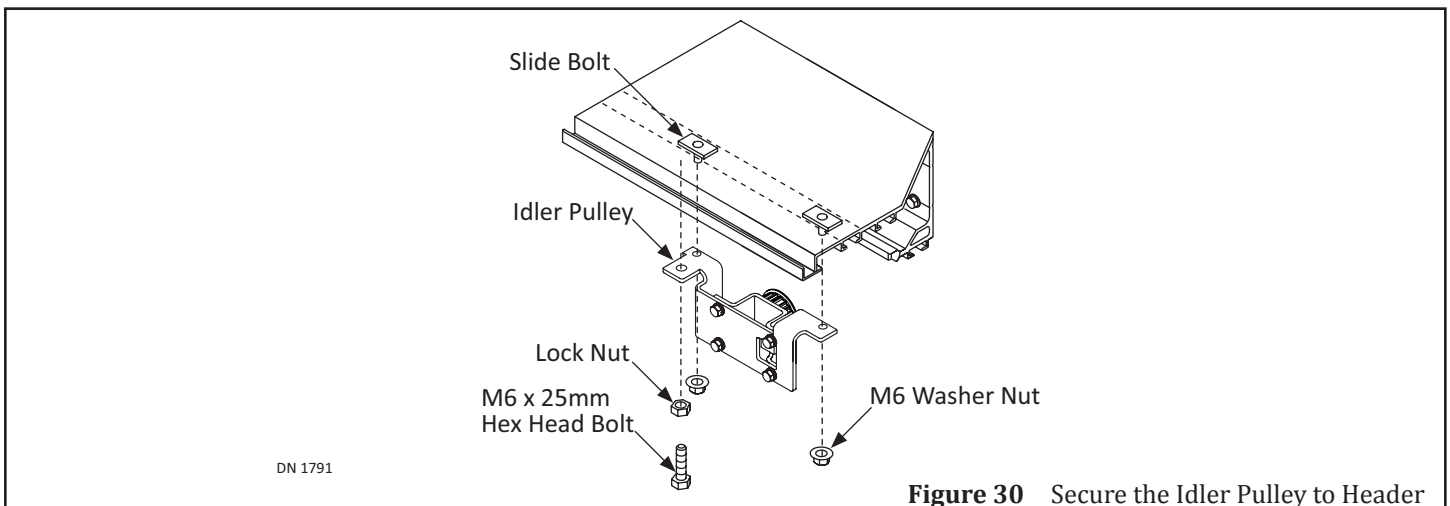

Figure 30 Secure the Idler Pulley to Header

1. Slide (2) Slide Bolts through Channel "A" according to Handing of Door:
 - ▶ Right Hand: Strike End of Header
 - ▶ Left Hand: Trail End of Header
2. Space the Slide Bolts 7.401 inches (188mm) apart.

3. Turn the Bracket so the Idler Pulley faces the back of Header (once installed).
4. Secure the Idler Pulley to the Slide Bolts with (2) M6 Washer Nuts. Loosely Tighten.
5. Fully Close the Slide Door. Ensure the Door Carrier does not hit the Idler Pulley. Tighten Bolts.
 - a. If the Carrier hits the Idler Pulley, slide the Idler Pulley until clearance can be achieved.

CHAPTER 15: INSTALL HEADER COMPONENTS

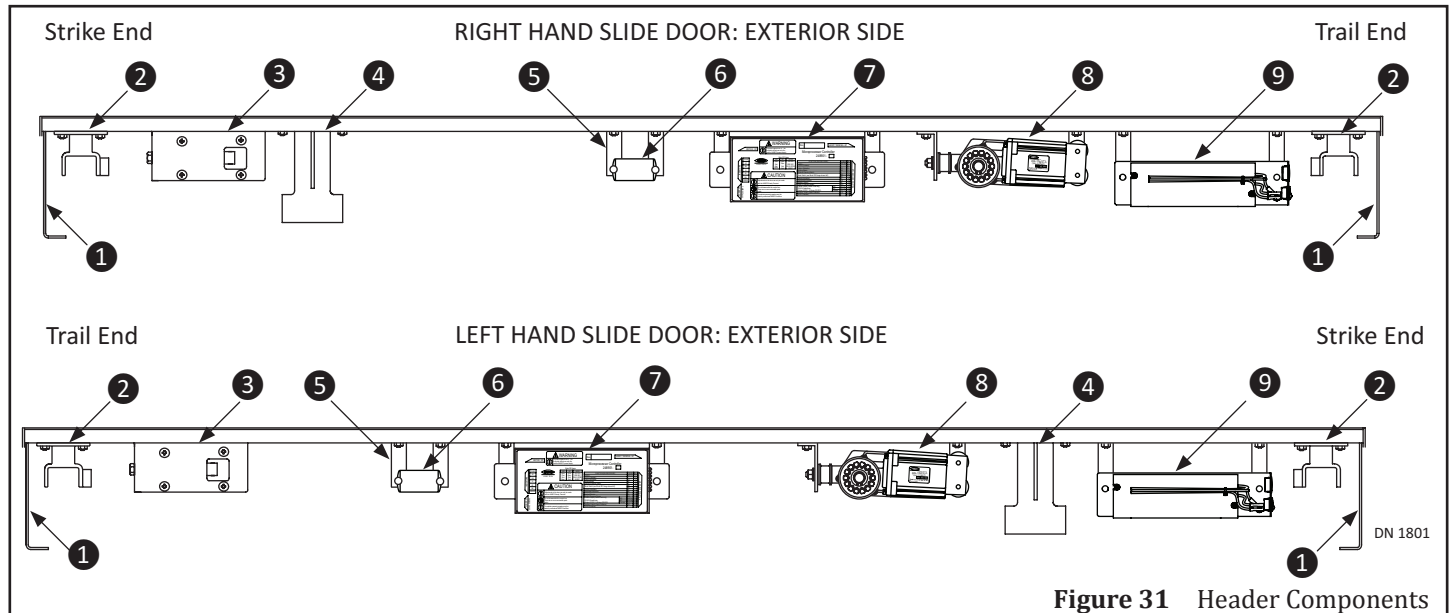

Figure 31 Header Components

1	Header Cover Bracket	4	Spring Mechanism Receiver	7	U30 Controller
2	Door Stop	5	Slide Bolt	8	Motor/Operator
3	Idler Pulley	6	Holding Beam Controller	9	Power Supply

SECTION 15.1: Install the Motor/Operator

15.1.1 Divide Slide Bolts within Header

Attention: Do Not slide the Slide Bolts on a Slanted angle. Doing so may cause damage to the Header.

1. Before installing the Motor/Operator, divide and then slide the Slide Bolts within the Header according to Handing of Door:
 - ▶ Right Hand:
 - (11) Slide Bolts on Strike side of Motor/Operator.
 - (7) Slide Bolts on Trail side of Motor/Operator (including the Motor/Operator).
 - ▶ Left Hand:
 - (9) Slide Bolts on Strike side of Motor/Operator.
 - (9) Slide Bolts on Trail side of Motor/Operator (including the Motor/Operator).

15.1.2 Assemble Motor/Operator

1. Obtain the Motor/Operator Parts Kit provided by NABCO.
 - a. Bracket "F" has (1) bolt hole on the top, and (1) bolt hole on its side.
 - b. Bracket "R" has (2) bolt holes on the top, and (2) bolt holes on the back.
2. Turn the Motor/Operator so the Drive Pulley is facing the back of Header (once installed).
3. Turn Bracket "F" so the top has (1) bolt hole, and the side has (1) bolt hole facing the Motor/Operator.
4. Slide Motor Bracket "F" onto the Bolt protruding from the end of Motor/Operator. Secure with (1) Lock Nut.
5. Turn Bracket "R" so (2) bolt holes are on top and (2) bolt holes face the back of Header (once installed).
6. Slide Motor Bracket "R" onto the Rubber Bushings located at the back of Motor facing the Header (once installed). Secure with (2) Lock Nuts.

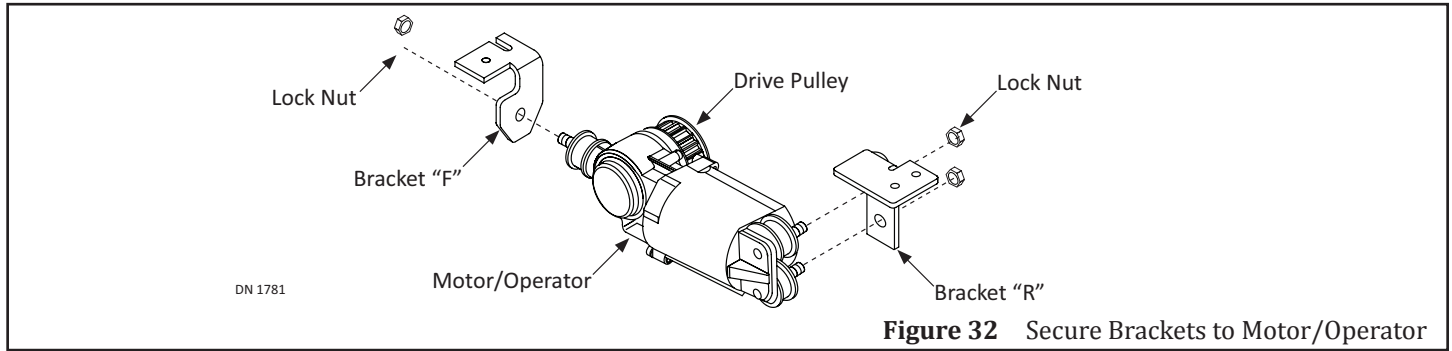

Figure 32 Secure Brackets to Motor/Operator

15.1.3 Secure Motor/Operator to Header

Attention: Do Not tighten M6 Washer Nuts on a Slanted angle. Doing so may cause damage to Components.

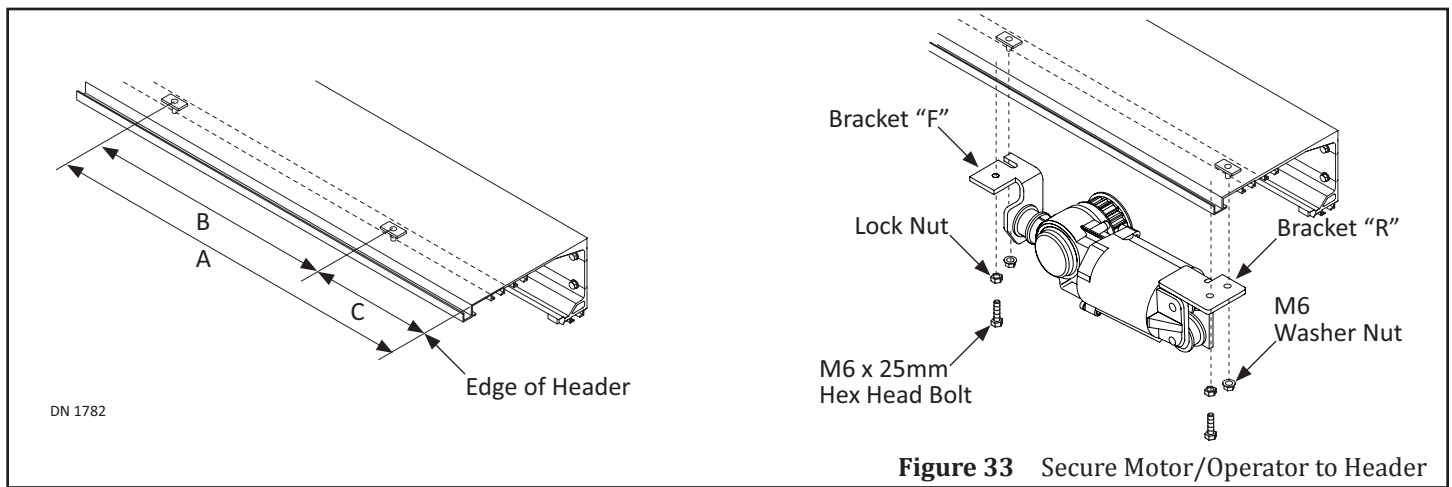

Figure 33 Secure Motor/Operator to Header

1. Slide (2) Slide Bolts through Channel "A" according to Handing of Door:
 - ▶ Right Hand: Trail End of Header according to Table 3.
 - ▶ Left Hand: Strike End of Header according to Table 3.

Table 3 Slide Bolt measurement for location of Motor/Operator within Header

Right Hand	A	C	Left Hand	A	C
NAX-SN	26.062" (662mm)	15.728" (399.5mm)	NAX-SN	34.330" (872mm)	23.995" (609.5)
NAX-SX			NAX-SX	39.842" (1012mm)	29.507" (749.5)
NAX-SG			NAX-SG	34.330" (872mm)	23.995" (609.5)
B	Width of Motor/Operator 10.334				

2. Secure the Motor/Operator to:
 - ▶ Each Slide Bolt Bracket with (1) M6 Washer Nut.
 - ▶ The Header with 2) M6 x 25mm Hex Head Bolts, and (2) Lock Nuts.

SECTION 15.2: Install the Drive Belt

WARNING When manually opening and closing the Slide Door; Do Not place Hand inside the Header, or between the Strike end of Door and Jamb Tube. Doing so may injure Hand.

Attention: Test the Drive Belt Manually, and Automatically to ensure the Drive Belt doesn't jump. Failure to make immediate adjustments may damage the Slide Door system.

1. Remove the Belt Clamp from the Belt Clip.
2. Wrap one end of the Drive Belt around the Drive Pulley, and the other end around the Idler Pulley.

3. Connect the (2) Belt ends as close as possible. Cut off any excess Drive Belt.
4. Slide the Belt Clip onto both ends of the Drive Belt.
5. Secure the Belt Clip with (2) M6 x 20mm Hex Bolts and (2) Washers.

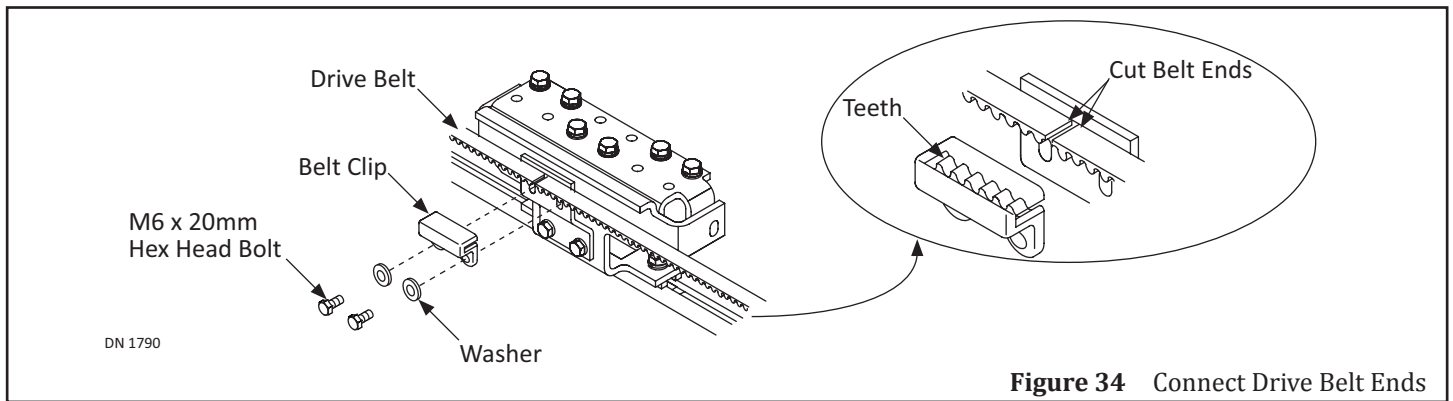

Figure 34 Connect Drive Belt Ends

6. Slide the Idler Pulley away from the Roller Carrier until the Drive Belt reaches the appropriate tension.
7. Fully tighten (2) M6 Washer Nuts.
8. Finish securing the Idler Pulley with (1) M6 x 25mm Hex Head Bolt and (1) Lock Nut.

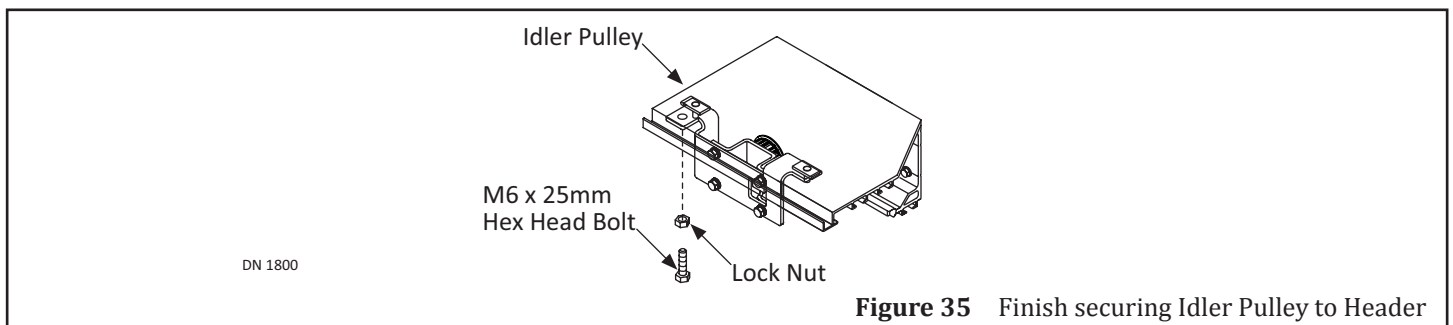

Figure 35 Finish securing Idler Pulley to Header

SECTION 15.3: Install the Power Supply

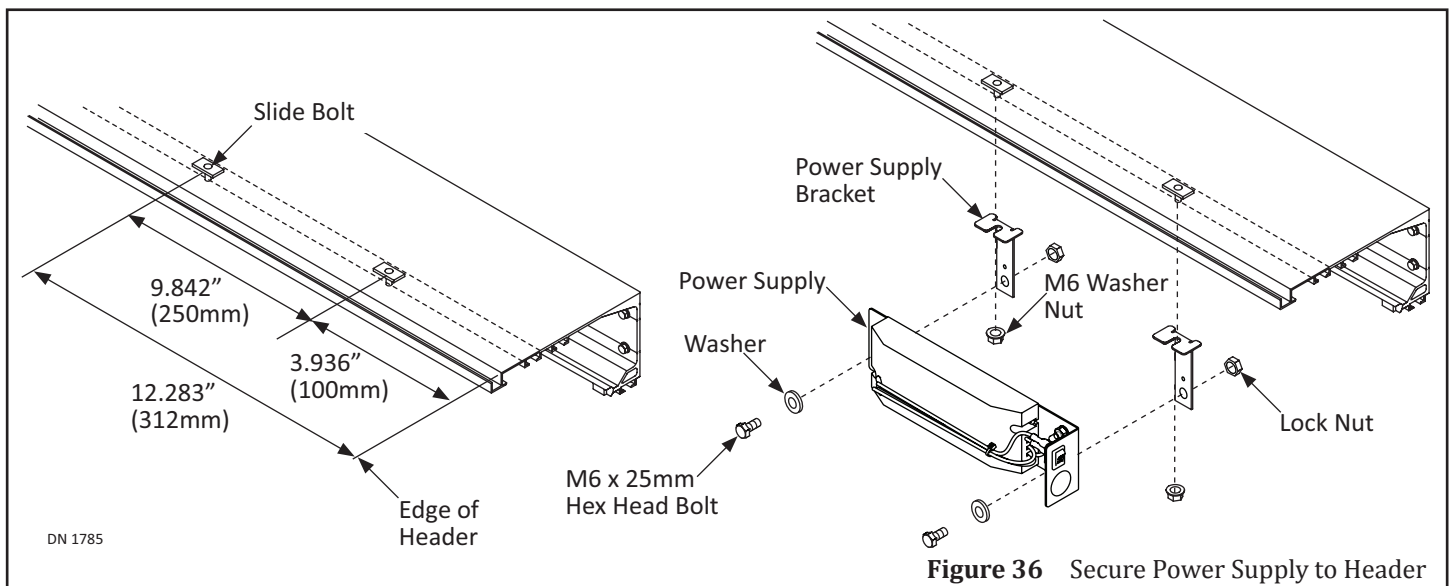

Figure 36 Secure Power Supply to Header

1. Slide (2) Slide Bolts through Channel "A" according to Handing of Door:
 - ▶ Right Hand Door: Go to Trail edge of Header.
 - ▶ Left Hand Door: Go to Strike edge of Header.
2. Measure:
 - ▶ 12.283 inches (312mm) towards the Center of Header. Slide (1) Slide Bolt to that measurement.
 - ▶ 3.936 inches (100mm) towards the Center of Header. Slide (1) Slide Bolt to that measurement.
3. Turn the Power Supply Bracket so the cut-out is on top, and the back plate with (1) bolt hole, faces the Interior side of Header (once installed). Secure with (1) M6 Washer Nut.
4. Turn the Power Supply so the Switch is on top, and faces the RIGHT Edge of Header (where End Cap is installed).
5. Secure the Power Supply to Brackets with (2) M6 x 25mm Hex Head Bolts and (2) Washers.

SECTION 15.4: Install the U30 Controller

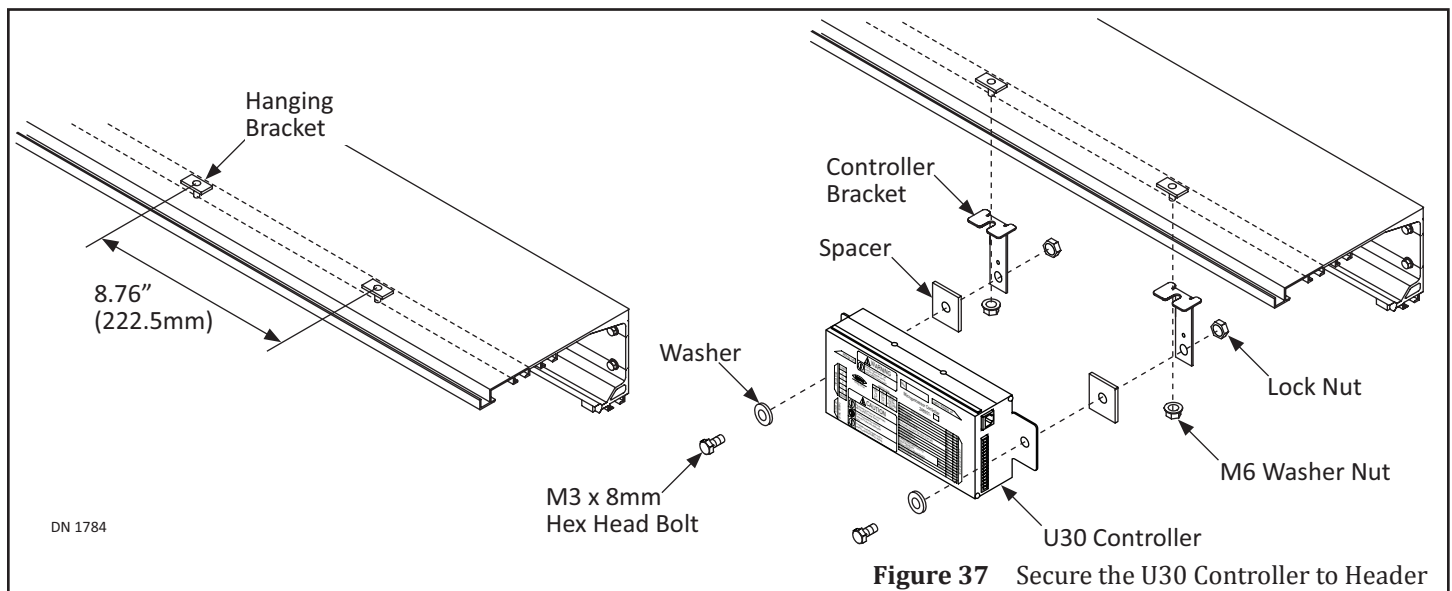

Figure 37 Secure the U30 Controller to Header

1. Slide (2) Slide Bolts through Channel "A" according to Handing of Door:
 - ▶ Right Hand Door: To the STRIKE side (to the left) of the Motor/Operator.
 - ▶ Left Hand Door: To the TRAIL side (to the left) of the Motor/Operator
2. Space (2) Slide Bolts 8.76 inches (222.5mm) apart.
3. Turn each Controller Bracket so the top plate with (1) cut-out is on top, and the back plate faces inside the Header.
4. Slide the cut out onto the Slide Bolt. Secure each Controller Bracket to the Slide Bolt with (1) M6 Washer Nut.
5. Insert (1) M3 x 8mm Hex Head Bolt through (1) Washer, and then through each side of the U30 Controller.
6. Go behind the U30 Controller. Slide (1) Spacer onto the each Bolt. Insert the Bolt assembly into each Controller Bracket. Secure with (1) Lock Nut.

SECTION 15.5: Install the Holding Beam Controller

1. The Holding Beam Controller can be installed within the Header where space is allowed. Just ensure to space the Slide Bolts 3.33 inches (84.582mm) apart.
2. Turn each Controller Bracket so the top plate with (1) cut-out is on top, and the back plate faces inside the Header.
3. Slide the cut out onto the Slide Bolt. Secure each Controller Bracket to the Slide Bolt with (1) M6 Washer Nut.
4. Insert (1) M6 x 25mm Hex Head Bolt through (1) Washer, and then through each side of the H.B. Controller Bracket.
5. Insert the Bolt assembly into each H.B. Controller Bracket. Secure with (1) Lock Nut.

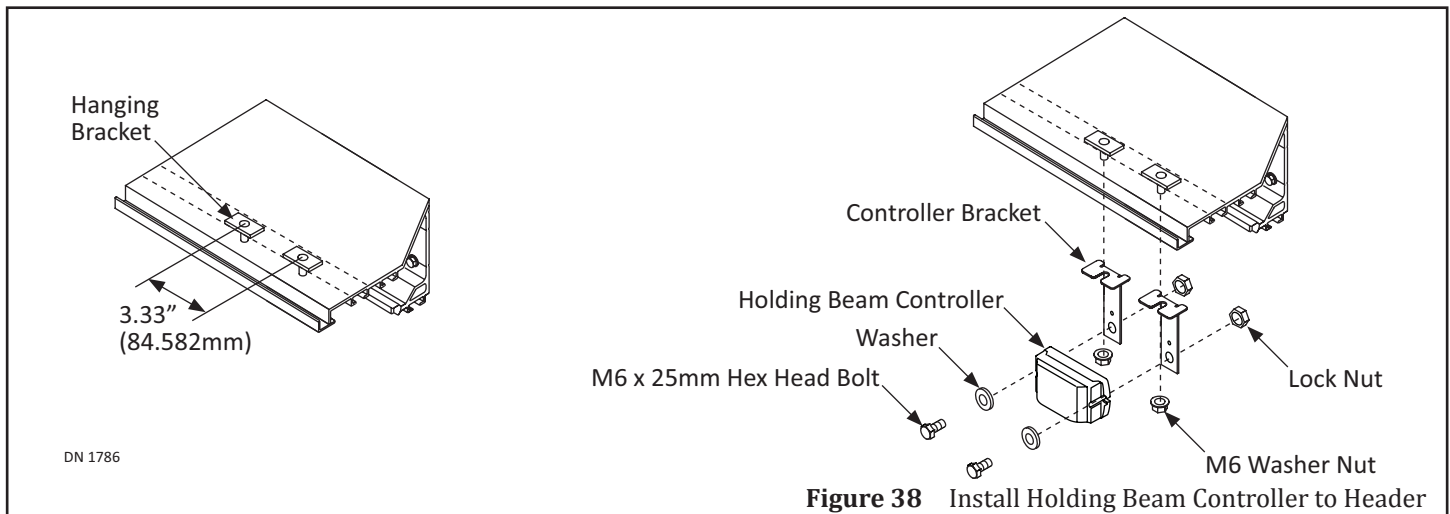

Figure 38 Install Holding Beam Controller to Header

SECTION 15.6: Install the Spring Mechanism Receiver

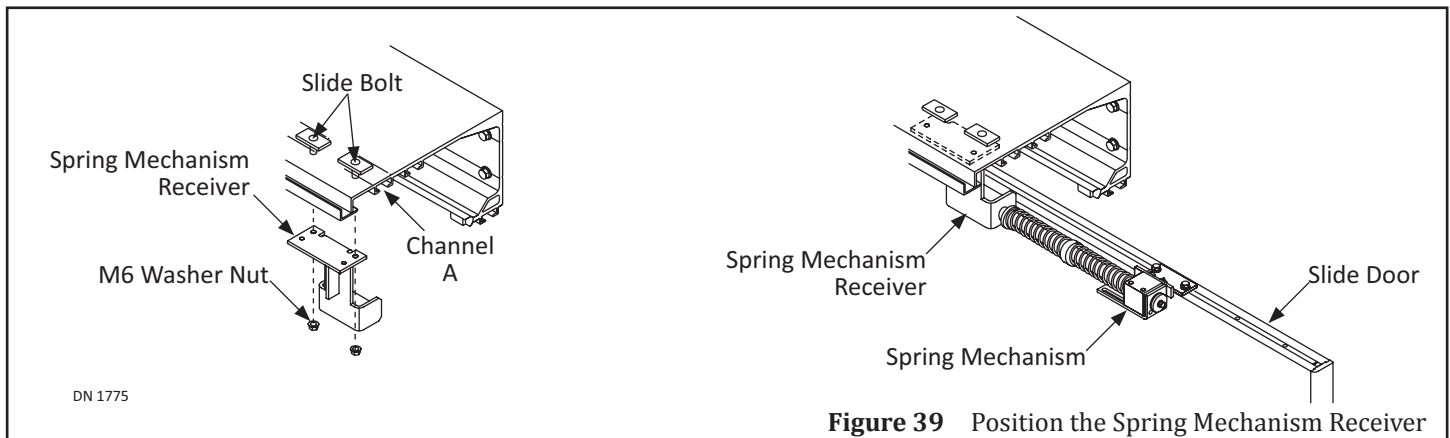

Figure 39 Position the Spring Mechanism Receiver

WARNING

When manually opening and closing the Slide Door; Do Not place Hand inside the Header, or between the Strike end of Door and Jamb Tube. Doing so may injure Hand.

Attention: When installing the Spring Mechanism Receiver, Do Not:

- ▶ Insert Slide Bolts on a Slanted angle. Damage may be caused to Header.
- ▶ Tighten M6 Washer Nuts on a Slanted angle. Damage may be caused to Components.

1. Go to the Strike side of Header. Insert (2) Slide Bolts through Channel "A".
2. Secure the Spring Mechanism Receiver to Slide Bolts with (2) M6 Washer Nuts. Loosely Tighten.
3. Fully Close the Door. Slide the Spring Mechanism Receiver through Channel "A", until the Rod inside the Spring Mechanism juts out between 3.54 inches - 3.75 inches (90mm - 95mm). This is called Contraction Allowance.

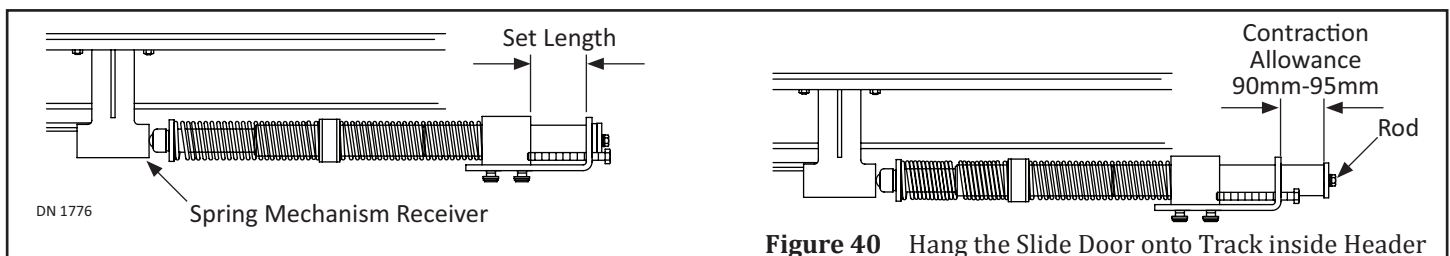

Figure 40 Hang the Slide Door onto Track inside Header

4. Hold the Spring Mechanism Receiver in place. Fully tighten the (2) M6 Washer Nuts.
5. Finish installing the Spring Mechanism Receiver with (2) M6 x 25mm Hex Head Bolts and (2) Lock Nuts.

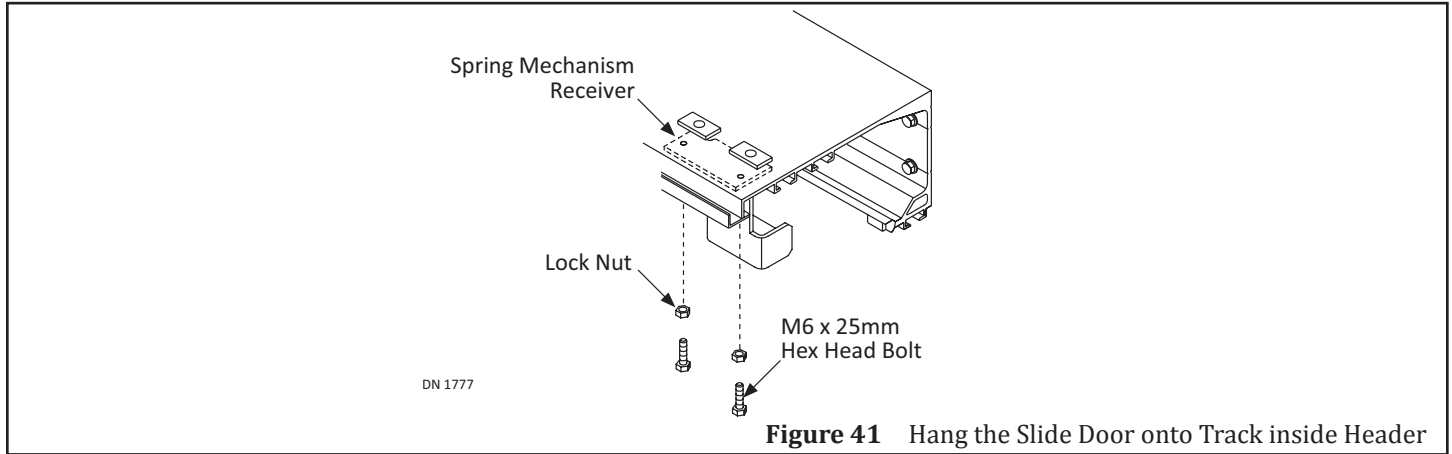
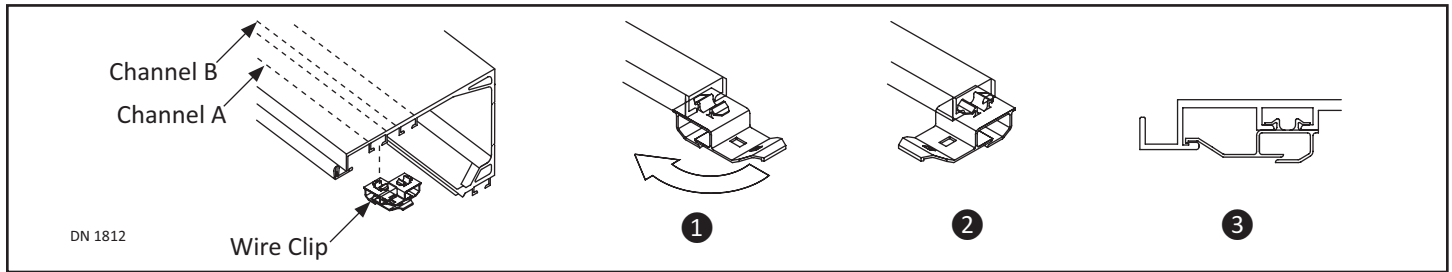

Figure 41 Hang the Slide Door onto Track inside Header

SECTION 15.7: Install Wiring Clips

1. Where wiring needs to be supported, Insert Wire Clips within Channel "A".
 - a. Use Channel "B" if other components will not allow clearance within Channel "A".



CHAPTER 16: 120 VAC GENERAL WIRING

- WARNING** Shut the installation site, branch Circuit Breaker OFF. Failure to do so may result in serious personal or fatal injury. When uncertain whether power supply is disconnected, always verify using a voltmeter.
- WARNING** All high voltage electrical connections must be made by licensed electricians according to Natnal and Local electrical codes/regulations.
- CAUTION** Keep all Incoming 120 VAC wiring separate from low voltage wiring within Header. 120 VAC Power wires must be routed (separate from other wiring) located near the top of inside Header.
- CAUTION** Ensure that the Grounding of the Electric Power Supply is installed/connected in a proper way (especially the PE Cable from the Building Side).

Attention: Insert all Incoming 120 VAC Power wires into the pre drilled Electric Service Access Hole located at the left or right side of Header End Cap.

Attention: Electrical circuit to Nabco operator must not be not shared with other equipment such as lighting, cash registers, or any device that might cause electrical interference on the circuit.

Note: It is recommended for the Installer to house all Incoming 120 VAC wires within an Electrical Conduit.

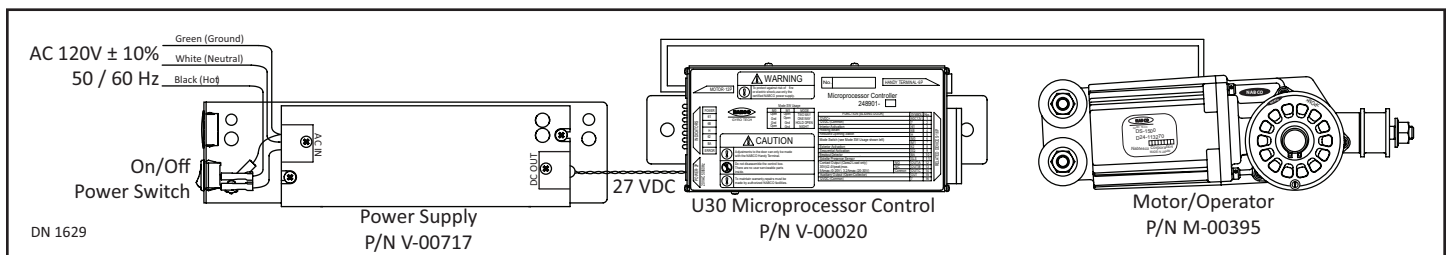

CHAPTER 17: INSTALL THE SPRING MECHANISM TO DOOR

Note: Please see the conversion chart located at the end of this manual for more information.

The Spring Mechanism is utilized to assist the **Opening Force** of the Slide Door:

- ▶ The looser the spring coils, the harder it will be to open the slide door.
- ▶ The tighter the spring coils the easier it will be to open the slide door.

SECTION 17.1: Set Preload (Spring Force)

Preload must be adjusted according to the mass of the Slide Door. Once the mass is determined the Spring can be tightened/loosened according to a Set Length of the Spring.

Note: Set Length is only to be used as a guideline. Actual adjustments must be made while testing the operation of the Door.

1. Measure the full length and full width of the Slide door.
2. Multiply the length and width of the door. For example, for a 4 foot x 7 foot door:
 $4' = 28'' = 711.2\text{mm} = 0.7112\text{m}$; $7' = 84'' = 2133.6\text{mm} = 2.1336\text{m}$
 Calculation: $0.7112\text{m} \times 2.1336\text{m} = 1.51\text{m}^2$
3. Select the appropriate Mass number listed within Table 4. For example: 40
4. Multiply (40) with the previous calculation. For example: $1.51\text{m}^2 \times 40 = 60.4\text{kg}$.

Table 4 Slide Door, Mass Chart (kg/m²)

Type	SUS*1	AL*2
NAX-SN	33	17
NAX-SX	56	40
NAX-SG	—	26
*1 Stainless Steel		
*2 Aluminum		

5. Take the Mass calculation and match it with the appropriate Door Mass Column located within Table 5. For example: (60.4m) is less than (70 kg). Because of that the L Dimension must be (13).

Table 5 Spring Force Chart (mm)

Door Mass	L Dimension (mm)	Door Mass	L Dimension (mm)
70 kg or less	13	111 to 120 kg	43
71 to 90 kg	23	121 to 130 kg	53
91 to 110 kg	33	131 to 150 kg	63

CAUTION Ensure the (2) Low Head Bolts are tight. If not, the main body of the Spring Mechanism may return causing injury to fingers, etc, between the Main Body and Adjustment Bracket.

1. Obtain the Spring Mechanism and (1) M8 x 80mm Bolt provided by NABCO. Remove all Hardware.
2. Go to the Adjustment Bracket located at the back of the Spring Mechanism. Locate a bolt hole on the same side as (2) Low Head Bolts.
3. Insert the M8 x 80mm Bolt as far as possible.
4. Go underneath the Bracket and loosen (2) Low Head Bolts.
5. Tighten the M8 Bolt to compress the Spring until the Set Length Dimension has been achieved.
6. Tighten the (2) Low Head Bolts as tight as possible. If not, injury could occur. Please see the Caution message listed above.
7. Test the Slide Door after installation is complete. To make final adjustments please see SECTION 23.1.

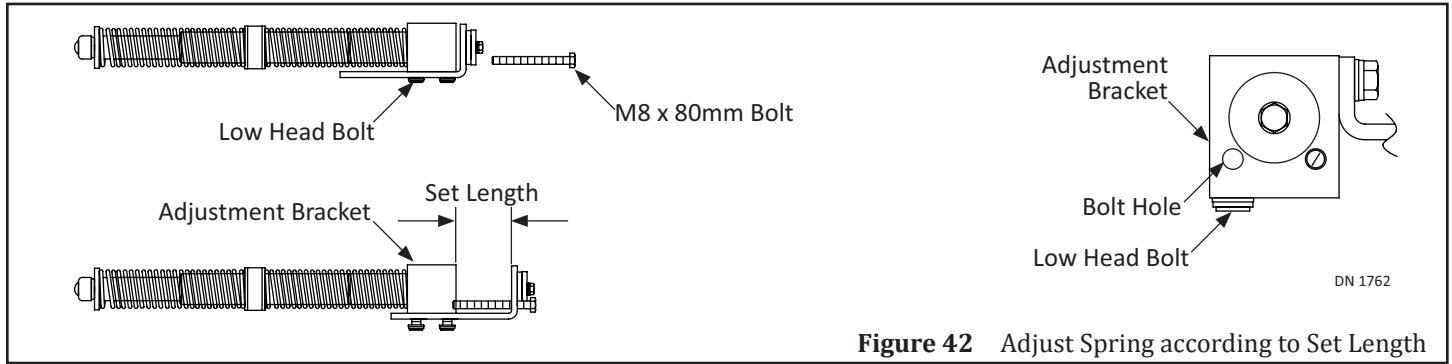

Figure 42 Adjust Spring according to Set Length

SECTION 17.2: Secure Spring Mechanism to the Mounting Plate

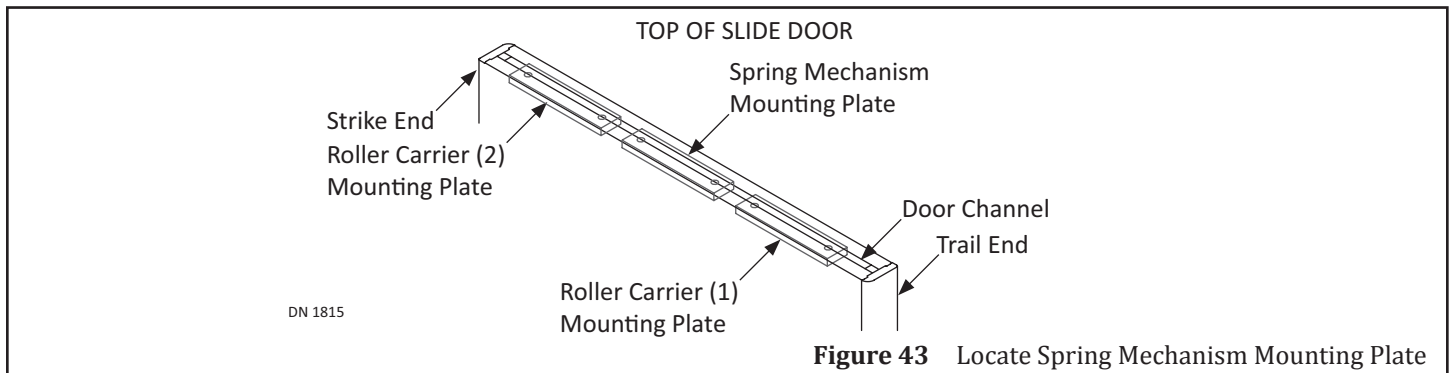

Figure 43 Locate Spring Mechanism Mounting Plate

1. Go inside the Door Channel. Locate the remaining Mounting Bracket in between the Roller Carriers.

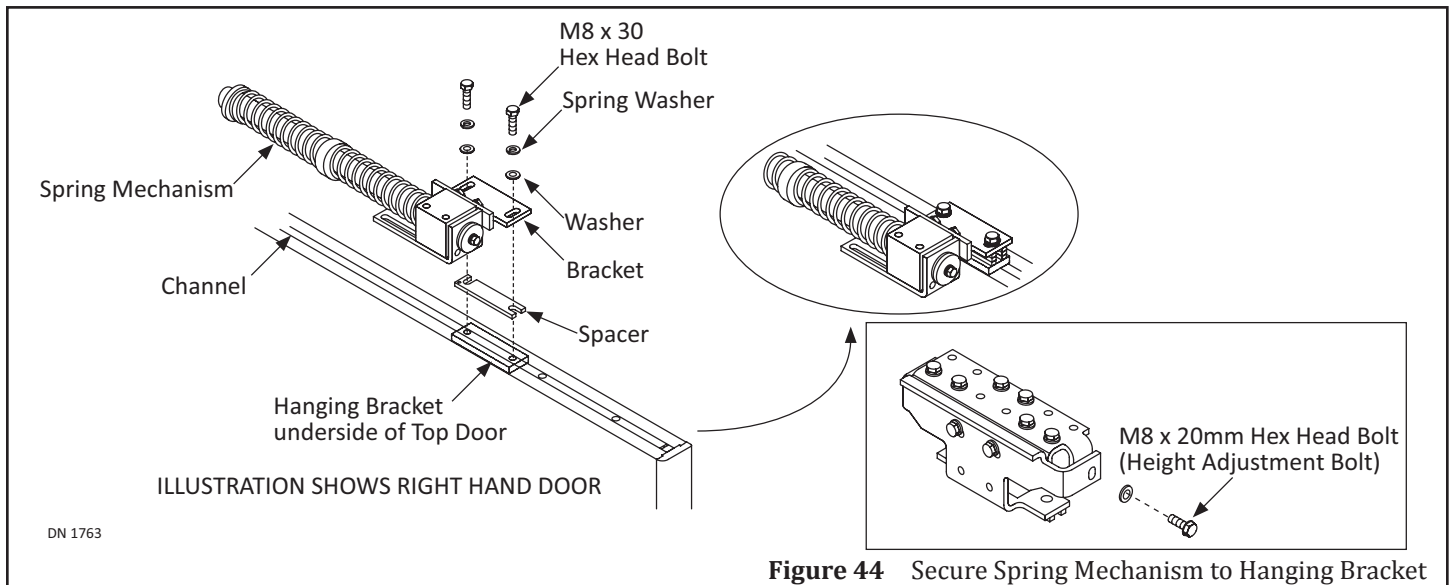

Figure 44 Secure Spring Mechanism to Hanging Bracket

2. Obtain the Spring Mechanism provided by NABCO. Place the Bracket portion on top of the Door so the Spring Mechanism hangs over the Exterior side of Door.
 - a. (5) Spacers have been provided by NABCO, use these spacers as deemed necessary between top of door and Bracket.
 - b. If utilizing the hanging height, adjustment Bolt (on Roller Carrier), remove spacers (1 thru 5) to the equivalent distance the door was raised. There is a risk of devices interfering.
3. Ensure the Spring Mechanism is square and level.
 - a. If the Spring Mechanism is secured at an angle, or tilted, noise may be caused and/or device failure may occur.
4. Secure the Spring Mechanism to the Mounting Plate with (2) M8x30mm Hex Head Bolts (2) Springs and (2) Washers. Loosely tighten.

CAUTION

If the Spring Mechanism is secured to the Door without proper measurements, or tilted/crooked, the Door may not run on the Track correctly, and/or Airtightness performance may fail.

5. Measure for proper position. From Trail edge of Door, measure towards the center:
 - ▶ NAX-SN, and NAX-SX Units: 13.287 inches (337.5mm), and 10.334 inches (262.5mm).
 - ▶ For NAX-SG Units: 15.255 inches (387.5mm), and 12.303 inches (312.5mm).
6. Ensure the center of Mounting Plate screw holes are aligned to these measurements.
 - a. If necessary, slide the Mounting Plate until proper position has been achieved.
7. Tighten the (2) M8x30mm Hexagon Head Bolts.

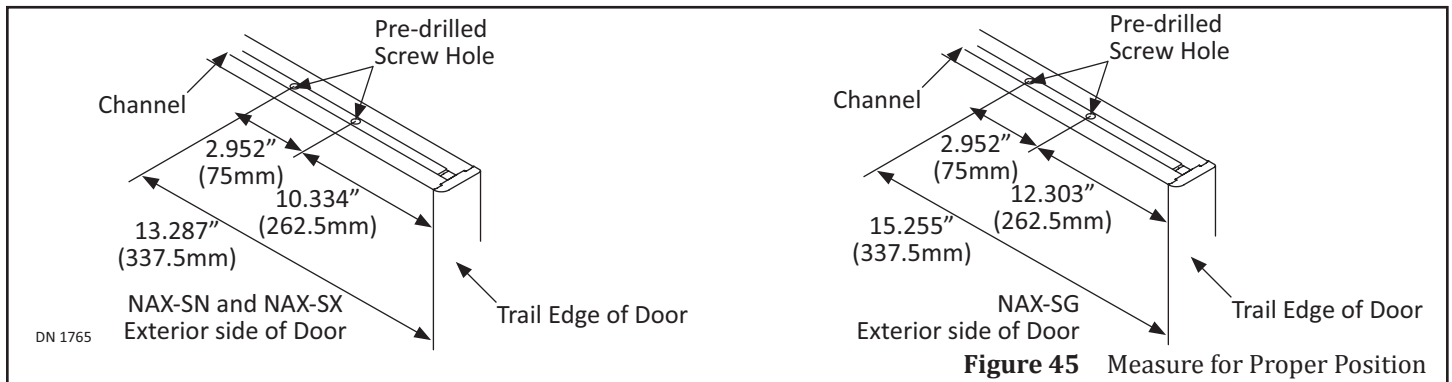

Figure 45 Measure for Proper Position

SECTION 17.3: Ensure Proper Slide Door Movement

WARNING

When manually opening and closing the Slide Door; Do Not place Hand inside the Header, or between the Strike end of Door and Jamb Tube. Doing so may injure Hand.

Note: If adjustments are deemed necessary please refer to CHAPTER 20.

1. Ensure Carrier Rollers rotate smoothly when manually sliding the Door, to the LEFT and RIGHT more than 11.810" (300mm)
 - a. If a Carrier Roller lifts from the Track, or does not rotate, or only slightly rotates, adjustments are necessary.

SECTION 17.4: Ensure Slide Door is Hermetically Sealed

Note: If adjustments are deemed necessary please refer to CHAPTER 20.

17.4.1 Ensure Slide Door is Square and Level

Note: If adjustments are deemed necessary please refer to CHAPTER 20.

1. Measurements must be the same for the following location points. If not, adjustments are necessary:
 1. Measure between the floor and bottom of the: Strike edge of Door, and Trail edge of Door.
 2. Measure between the Header and top of the: Strike edge of Door, and Trail edge of Door.
 3. Measure between the Horizontal Jamb Tubes and Slide Door at the: Top, and Bottom.

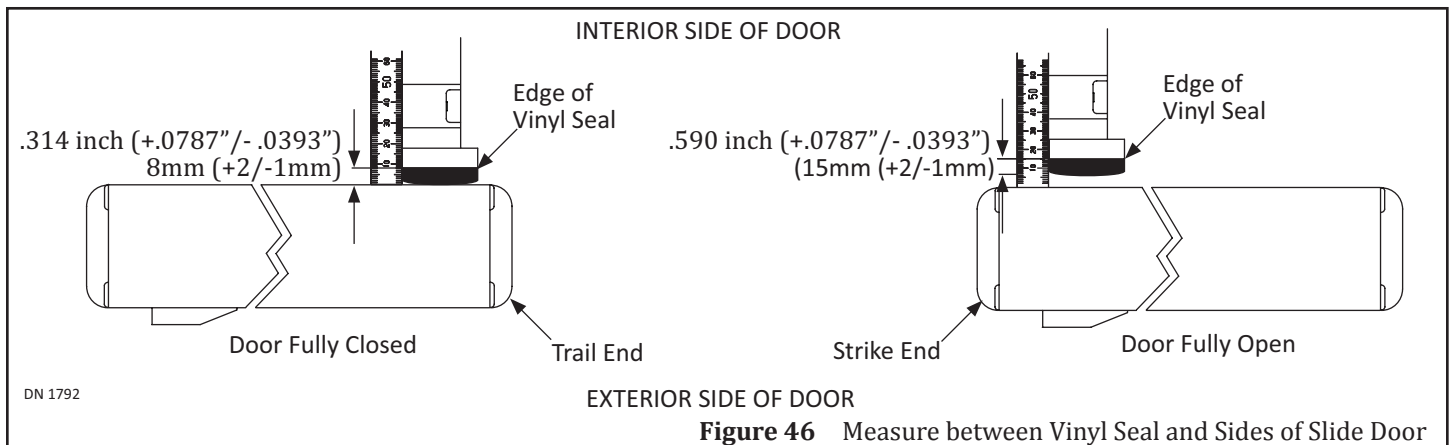

Figure 46 Measure between Vinyl Seal and Sides of Slide Door

17.4.2 Measure between Vinyl Seal and Three Sides of Slide Door

1. Fully Close the Slide Door.
2. On the Interior Side of Door. Go to each Jamb Tube.
3. Measure between the point where the Vinyl Seal starts to protrude from the Jamb Tube; to the surface of Slide Door.
 - a. Measurement must not exceed .314 inch (+.0787" / - .0393"); 8mm (+2/-1mm).
 - b. Insert a credit card. If the credit card drops out between the Vinyl seal and Jamb Tube, adjustments must be made.
 - c. There must not be any GAPS.
4. Fully Open the Slide Door. Go to each Jamb Tube.
5. Measure between the point where the Vinyl Seal starts to protrude from the Jamb Tube; to the surface of Slide Door.
 - a. Measurement must not exceed .590 inch (+.0787" / - .0393"); 15mm (+2/-1mm).
 - b. There will be a GAP.

17.4.3 Measure between Vinyl Seal and the Floor

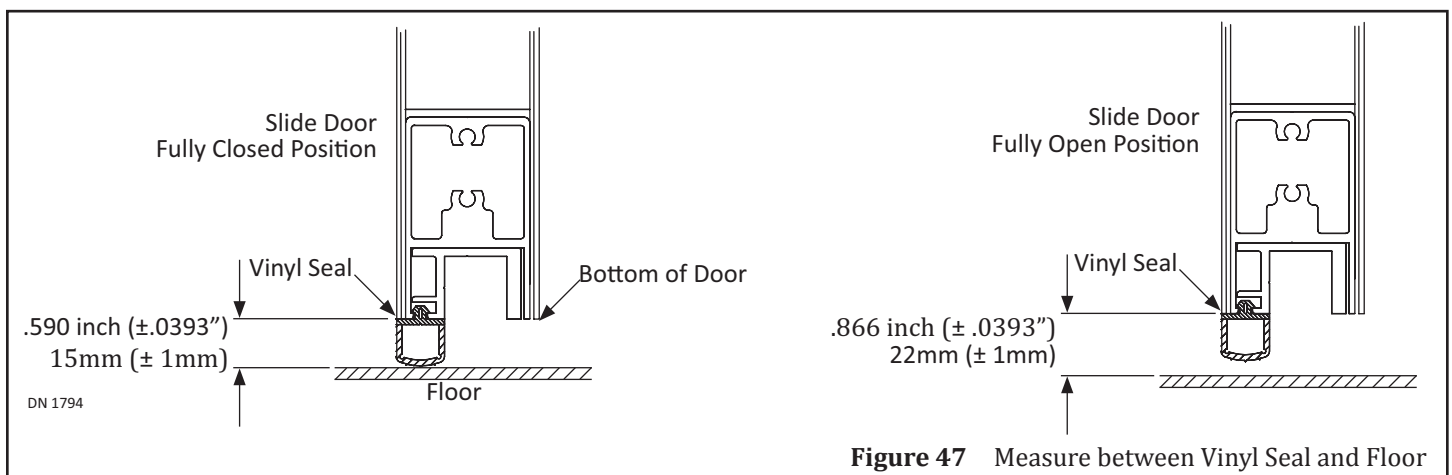
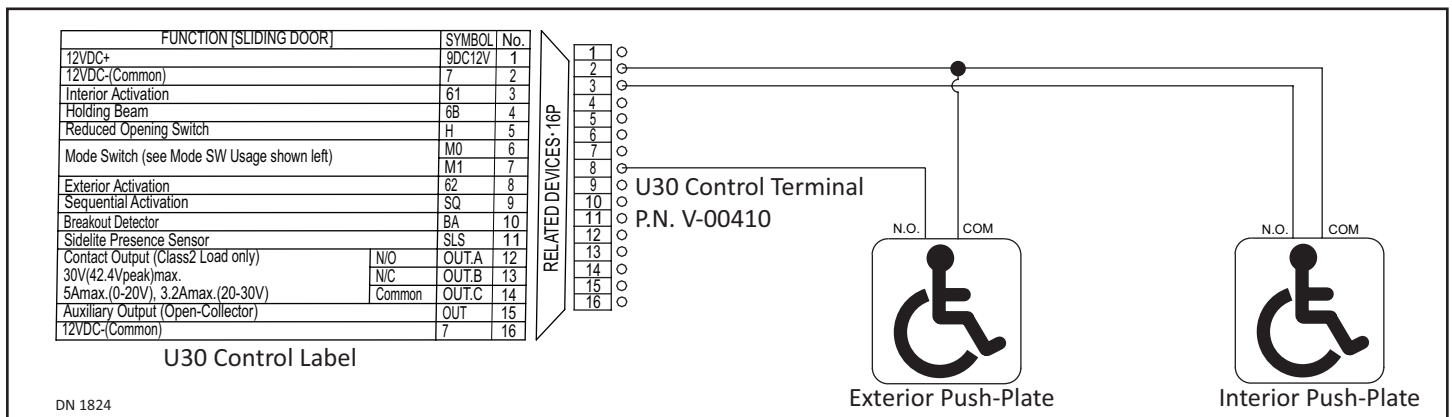

Figure 47 Measure between Vinyl Seal and Floor

1. Fully Close the Slide Door. Go to the Bottom of Slide Door.
2. Measure between the the point where the Vinyl Seal starts to protrude from the Jamb Tube; to the surface of Floor.
 - a. Measurement must not exceed .314 inch (+.0787" / - .0393"); 8mm (+2/-1mm).
 - b. Insert a credit card. If the credit card drops out between the Vinyl seal and Jamb Tube, adjustments must be made.
 - c. There must not be any GAPS.
3. Fully Open the Slide Door. Go to the RIGHT Jamb Tube.
4. Measure between the the point where the Vinyl Seal starts to protrude from the Jamb Tube; to the surface of Slide Door.
 - a. Measurement must not exceed .866 inch (± .0393")22mm (± 1mm). There will be a GAP.

CHAPTER 18: GENERAL WIRING

SECTION 18.1: Passive Activation Devices



DN 1824

SECTION 18.2: Passive Activation Devices (ON/OFF/HOLD-OPEN Switch)

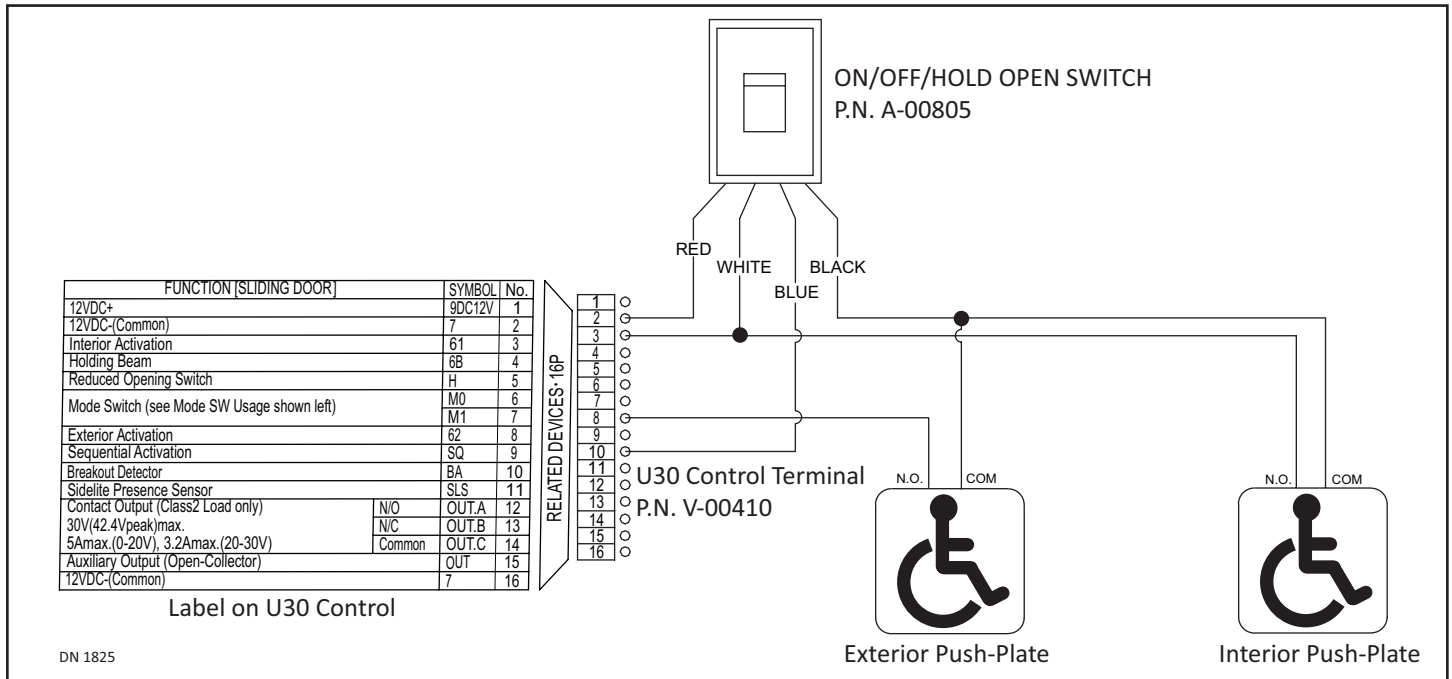

SECTION 18.3: Powered Activated Devices

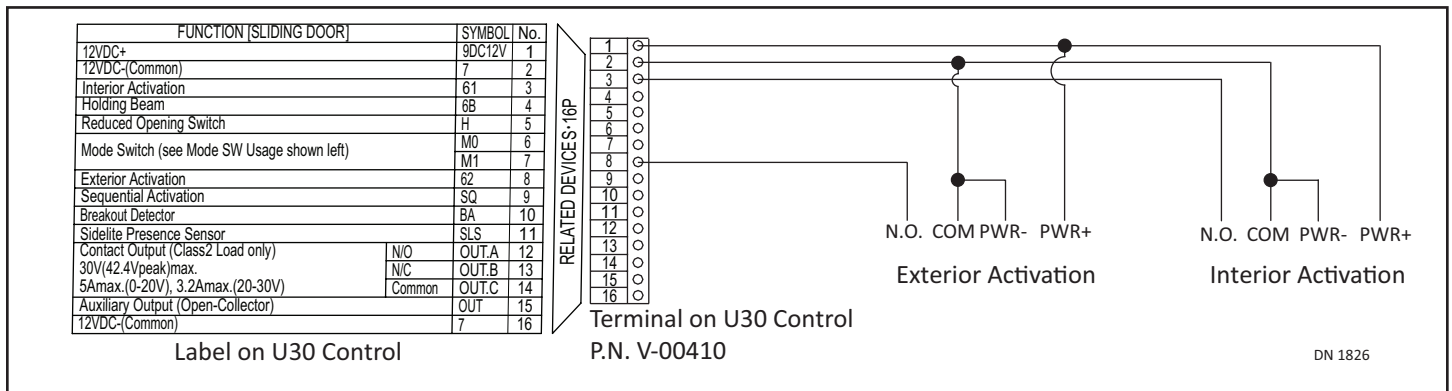

SECTION 18.4: Safety Sensors

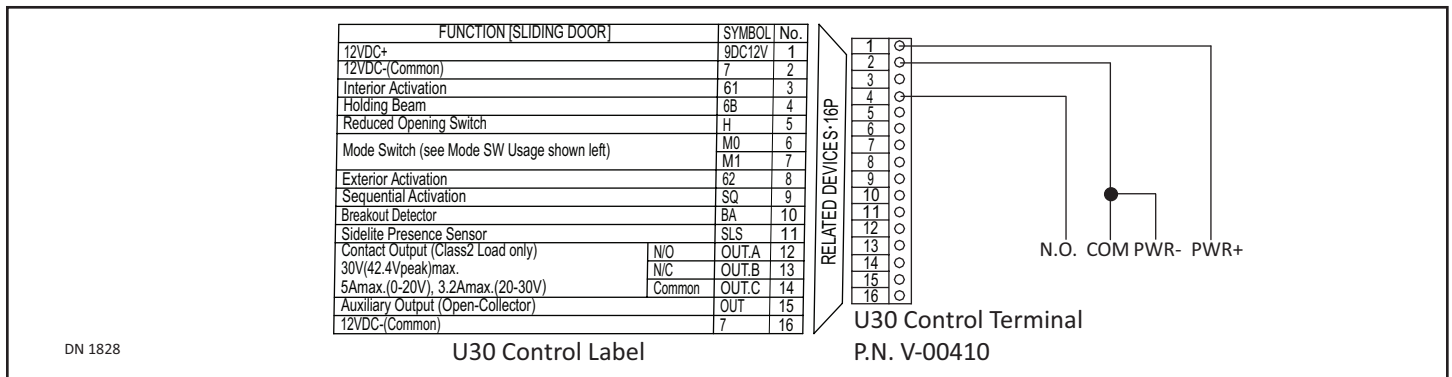

SECTION 18.5: Safety Sensors with Monitoring

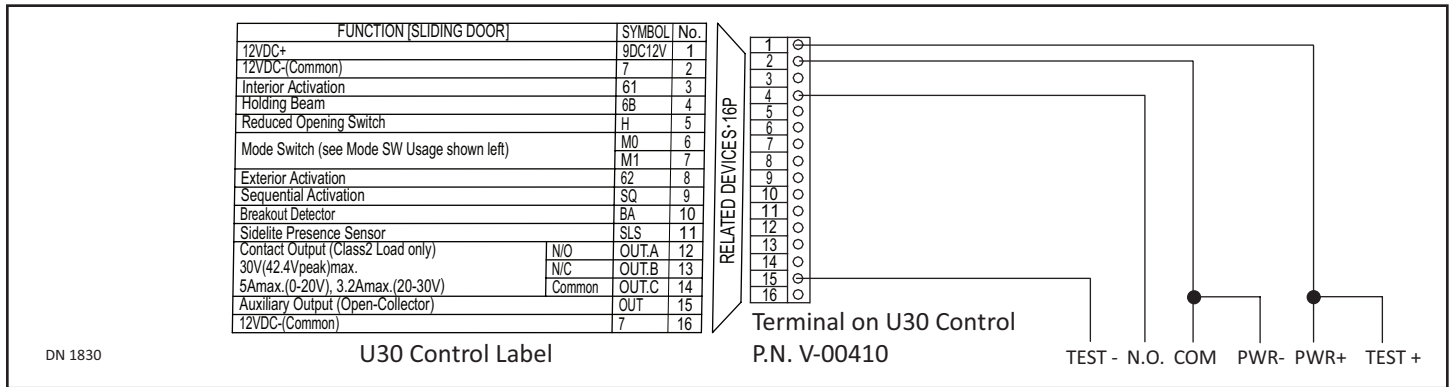

SECTION 18.6: Powered Activation Devices (ON/OFF/HOLD-OPEN Switch)

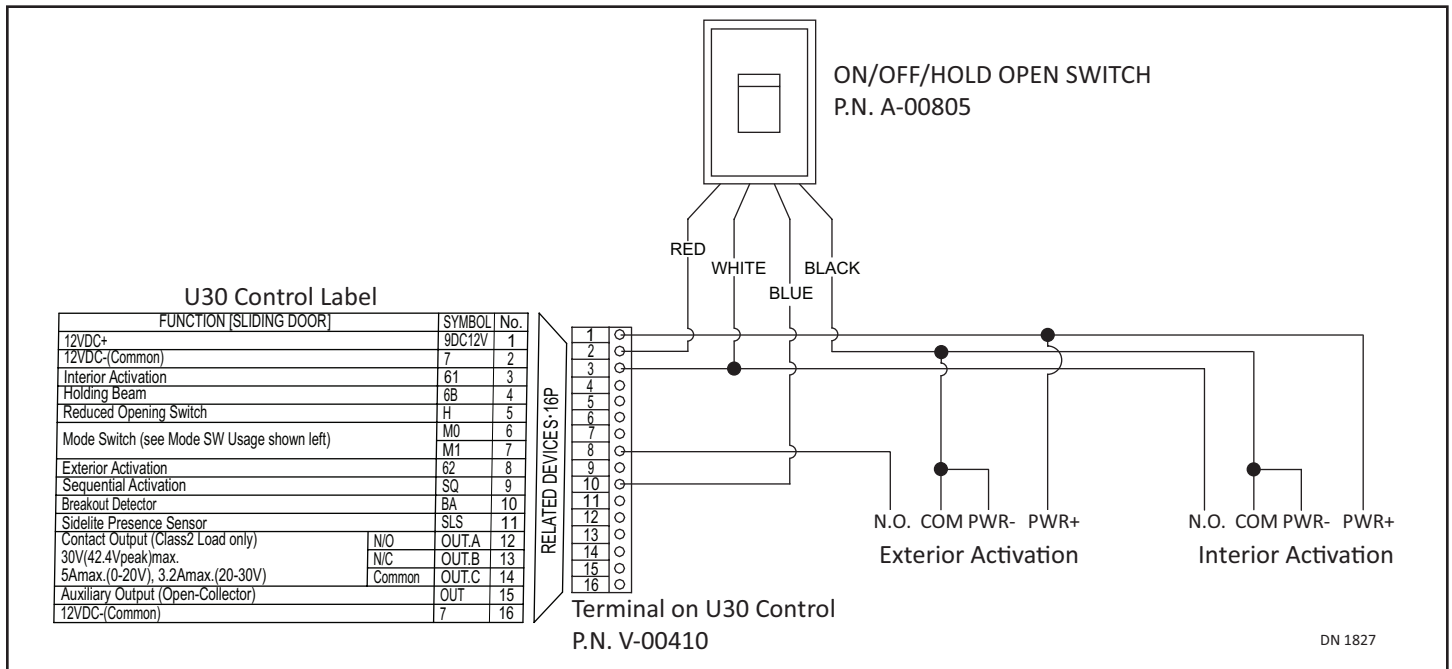

CHAPTER 19: HANDY TERMINAL PROGRAMMING

Attention: The following table lists programming values that are both default, and unique to the NAX Hermetic Slide Door. For detailed description of each value listed below, please refer to the "U30 "E" Setup and Programming Manual; P/N C-00203" (provided within the Decal Packet).

Note: Extra Functions Adjustments settings are only available with the use of the Blue Handy Terminal.

1. Upon initializing the Handy Terminal, press the ENTRY button until the desired Adjustment Function is displayed.
2. Start the programming ➡ Press the Shift buttons to select Y ➡ Press ENTRY

Unique Values for NAX Slide Door and NABCO Default Quick Reference Table			
Adjustment	Value Description	Unique to NAX	NABCO Default
Standard Function Adjustment	Opening Speed		3
	Closing Speed		2
	Time Delay		2

Unique Values for NAX Slide Door and NABCO Default Quick Reference Table			
Adjustment	Value Description	Unique to NAX	NABCO Default
Feeling Adjustments	Start Power		3
	Check Power		6
	Reaction Power		4
	Back Check Speed		1
	Latch Check Speed	3	1
Special Function Adjustments	Hold Close	N	Y
	Holding Beam		Y
	Recycle/Rotation Direction	Y	N
	After Recycle		Y
	Recycle Sensitivity	3	1
	Reduced Opening		-
	Auxiliary Output		3
	Power On		0
	Manual Opening		0
	Extended Time Delay		7
Extra Function Adjustments	Function (1)		N
	Function (2)		N
	Function (3)		N
	Function (4)		N
	Function (5)		N
	Function (6)		N
	Function (11)		0
	Function (12)		0
	Function (13)		1
	Function (14)		0
	Function (15)		0
	Function (16)		0
	Function (17) (0) only if Holding Beam is not installed on NAX door	0	1
	Function (18)	0	3
	Function (21)		0
	Function (22)		0
	Function (23)		7

CHAPTER 20: INSTALL THE HEADER COVER

1. From each side of Header, measure: 0.787 (20mm) towards the Center of Header. Insert (1) Slide Bolt through Channel "A" to that measurement.
2. Turn the Cover Mounting Bracket so both the top and bottom plates, face the inside of the Header; and the plate with the bolt hole extending from the Bracket is on Top, facing the back of Header (once installed).
3. Secure each Cover Mounting Bracket to the Slide Bolt with (1) M6 Washer Nut.

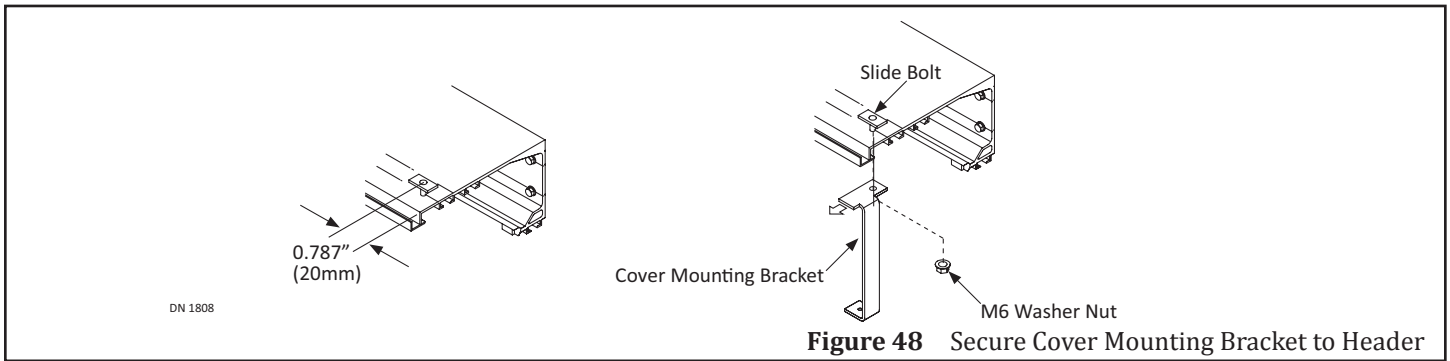

4. Obtain the Vinyl Seal. The Vinyl Seal may need to be cut more than once. If so:
 1. Slide the Vinyl Seal onto the Lip of Header at both ends. It is critical that both ends have Vinyl Seal.
 2. Space the rest of the Vinyl Seal 39.369 (1000mm) apart. Slide onto the lip of Header.
5. Slide the Cover onto the Lip of Header.
6. Swing the Cover to the fully closed position.
7. Secure the Cover to each Bracket with (1) M4x8 Pan Head Screw.

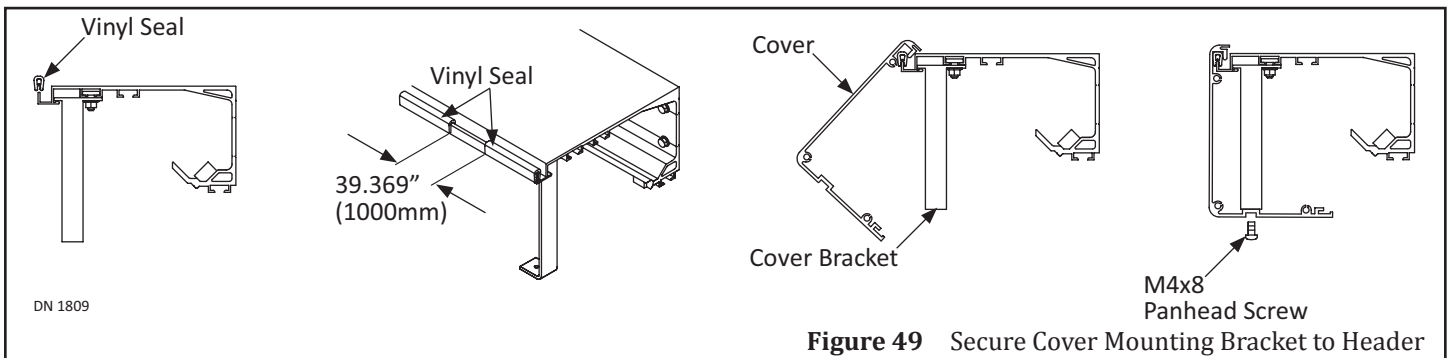

CHAPTER 21: INSTALL THE END CAPS

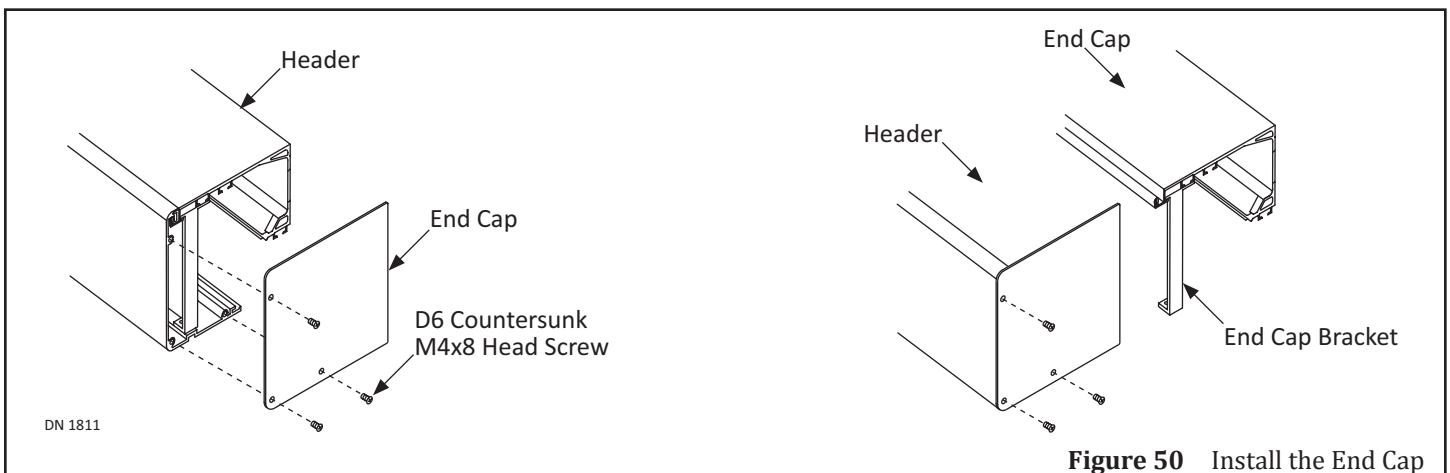

1. Secure the (1) End Cap to each side of the Header with (3) D6 Countersunk, M4x8 Head Screws:
 - ▶ After the Header Cover has been installed.
 - ▶ Before the Header Cover has been installed (for restrictive openings).

CHAPTER 22: INSTALL THE DOOR HANDLE

SECTION 22.1: Recessed Handle

The Recessed Handle is installed at the NABCO Factory.

SECTION 22.2: Tubular Handle

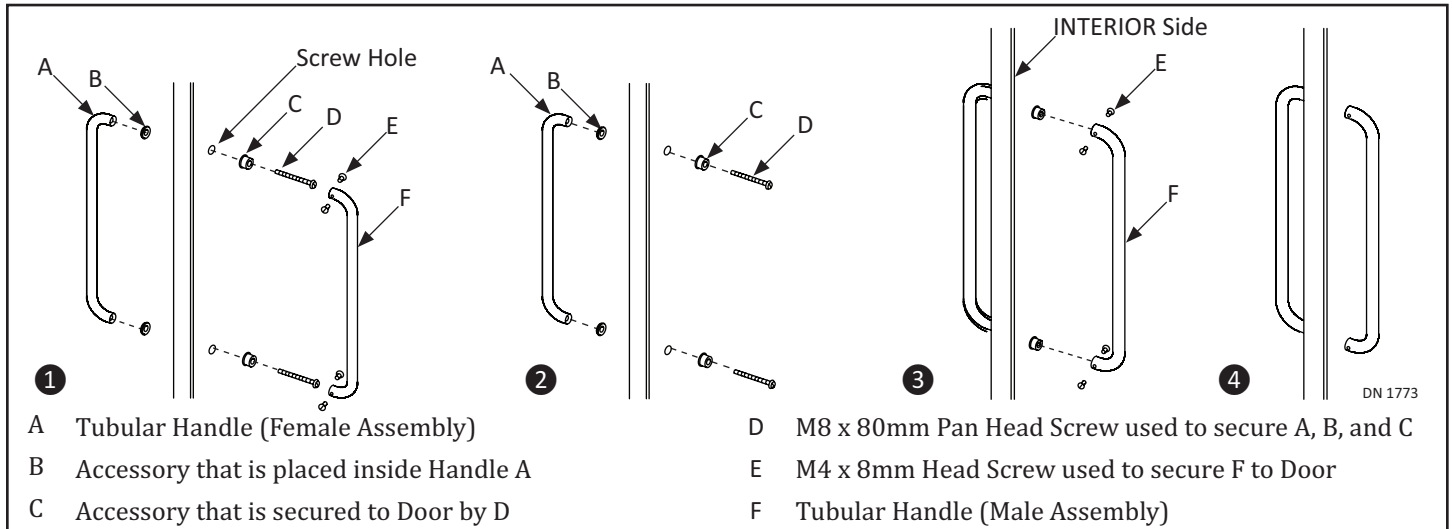

SECTION 22.3: Lever Handle

1. Install the Male Assembly (A) on the: Exterior side for RIGHT Hand Door; Interior side for LEFT Hand Door.

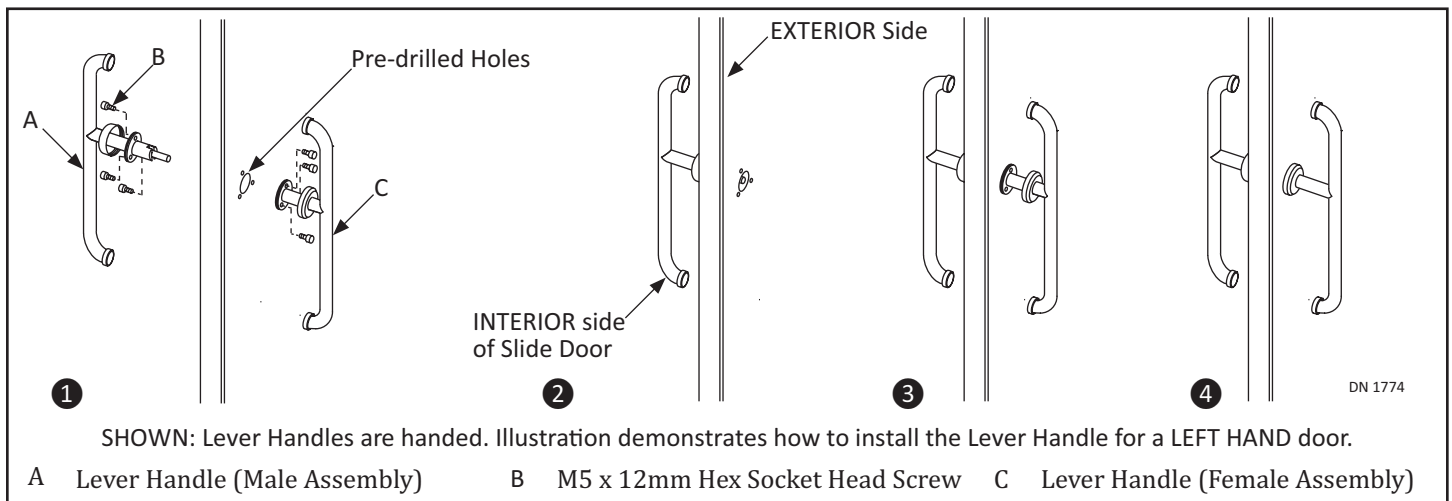

CHAPTER 23: ADJUSTMENTS

WARNING

Shut the installation site, branch Circuit Breaker OFF. Failure to do so may result in serious personal or fatal injury. When uncertain whether power supply is disconnected, always verify using a voltmeter.

SECTION 23.1: Adjust the Spring Mechanism

Note: Final adjustments must be made in combination with the U30 Controller.

1. Adjust the Slide Door for proper operation according to Table 6.

Table 6 Test the Spring Mechanism

Check	Adjust
Door must Fully Close.	If door does not fully close during automatic closing operation: Loosen the Spring Force. Adjust the way the Door is hung (contact between Vinyl Seals may be too tight).
Door must not Open from Fully Closed position when Power is turned OFF.	If door starts to open: Loosen the Spring Force.
Close-Safety must not occur when the Spring Mechanism comes into contact with the Spring Mechanism Receiver.	If Close-Safety (reverse opening movement) occurs: When the door is running on the slope on the rail, loosen the Spring Force. Immediately after the contact, shift the position of the Spring Mechanism receiver in the Close direction.
Manually Open/Close the Slide Door when Power is OFF	If Open/Close manual operation is abnormally heavy (300 N or above) when Power is OFF: Tighten the Spring Force.

SECTION 23.2: Adjust Roller Movement within Track

WARNING Do Not loosen (2) M8 x30mm Hex Head, Fixing Bolts too much. If loosened excessively, there is a risk that the Slide Door may fall down and cause injury.

1. Go to the side of Carrier. Remove (1) M8 x30mm Hex Head Bolt, and (1) Washer.
 - a. This is commonly referred to as the Height Adjustment Bolt.
2. Go to the front plate of Carrier. Locate and then slightly loosen (2) M8 x30mm Hex Head, Bolts.
 - a. Do Not excessively loosen. The Slide Door may fall down and cause injury.
3. To adjust Roller Height, manually slide the Door to the left or right about 1.968 inches (50mm) to ensure all Carrier Rollers are properly seated within the Header Track.
4. Repeat Step 3 until Rollers firmly touch the Track and rotate appropriately.
5. Tighten the (2) M8 x30mm Hex Head, Fixing Bolts.
6. Replace (1) M8 x30mm Hex Head Bolt, and (1) Washer. Tighten.

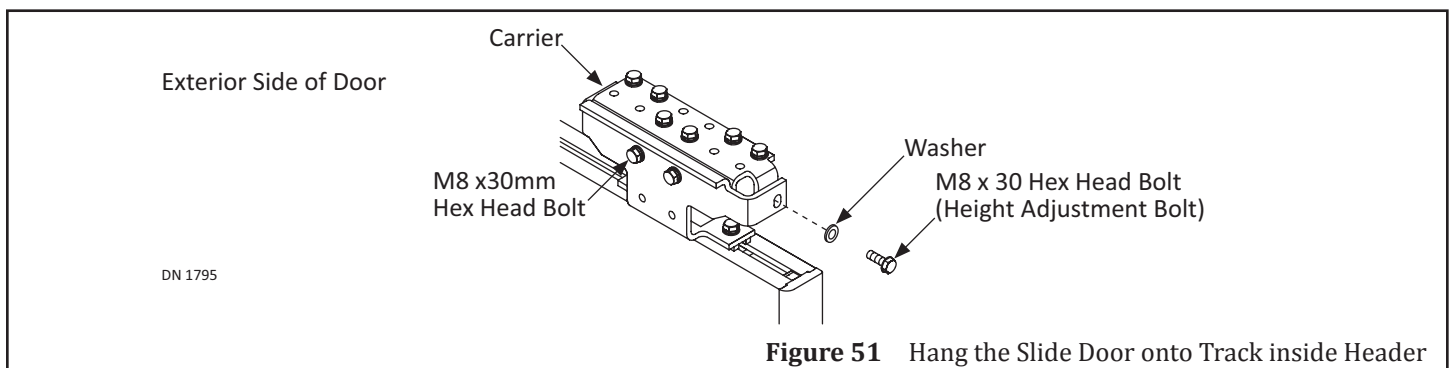

SECTION 23.3: Adjust the Drive Belt

Attention: Test the Drive Belt Manually, and Automatically to ensure the Drive Belt doesn't jump. Make adjustments accordingly. Failure to make immediate adjustments may damage the Slide Door system.

1. Go to the Idler Pulley Assembly. Loosen (4) M8 x 30mm Hex Head Bolts, and (4) Springs, plus (4) Washers just enough for the Springs and Washers to no longer butt up against the Face Plate. Do Not remove the Hex Head Bolt assembly.
2. Turn the Tension Adjustment Bolt:
 - ▶ Clockwise to Tighten the Drive Belt (long in length).
 - The Pulley will move towards the Center of Header.
 - ▶ Counterclockwise to Loosen the Drive Belt (short in length).
 - The Pulley will move towards the Strike End of Header.

3. Temporarily Tighten the (4) M8 x 30mm Hex Head Bolts, and (4) Springs, plus (4) Washers.
4. Manually, Open and Close the Slide Door to ensure the Drive Belt no longer jumps.
5. Tighten the (4) M8 x 30mm Hex Head Bolts, and (4) Springs, plus (4) Washers.

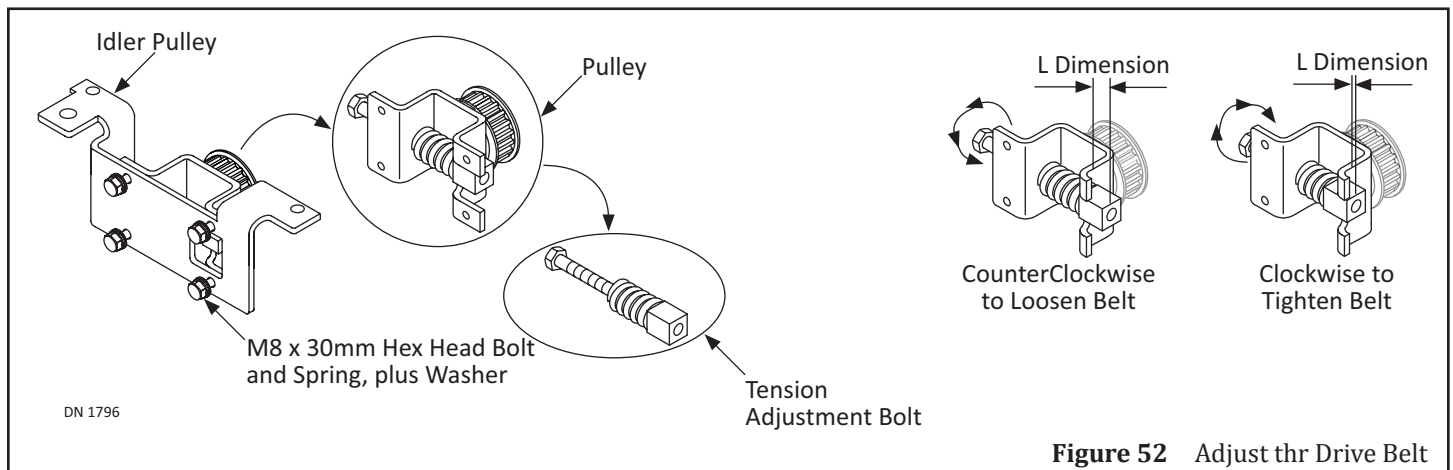

SECTION 23.4: Adjust Small Gap between Door and the Floor

1. Go to the side of Carrier. Remove (1) M8 x30mm Hex Head Bolt, and (1) Washer.
 - a. This is commonly referred to as the Height Adjustment Bolt.
2. Go to the front plate of Carrier. Locate and then slightly loosen (2) M8 x30mm Hex Head Bolts.
 - a. Do Not excessively loosen. The Slide Door may fall down and cause injury.
 - b. The weight of the Slide Door will automatically lower the (2) M8 x30mm Hex Head, Bolts.
 - c. Ensure each Carrier is square and level.
3. Tighten the (2) M8 x30mm Hex Head Bolts.
4. Replace (1) Height Adjustment Bolt and (1) Washer.

SECTION 23.5: Adjust Large Gap between Door and the Floor

1. Manually open the Slide door until it is almost in the fully open position.
2. Remove (2) M8 x 30 Hex Head Bolts, (2) Springs, and (2) Washers used to remove the each Carrier.
3. Add Spacers as deemed necessary to lower the Slide Door.
 - a. (5) Spacers per Carrier has been provided by NABCO.
4. Secure the Carrier with (2) M8 x 30 Hex Head Bolts, (2) Springs, and (2) Washers.
5. Ensure the Slide door is square and level.

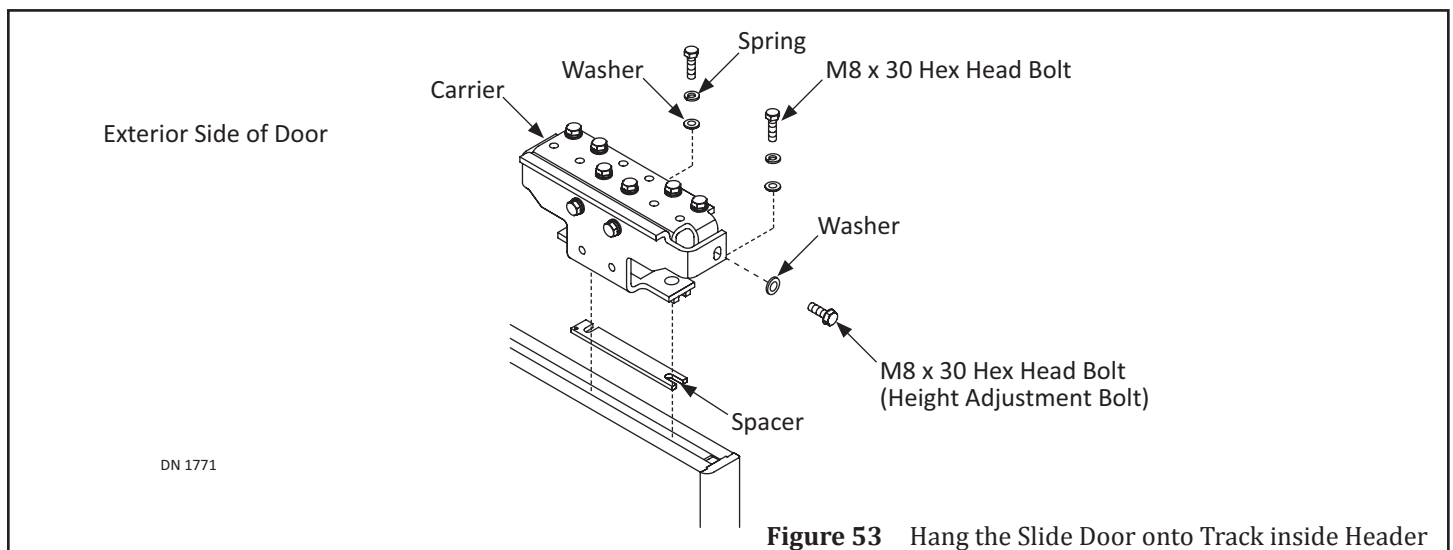

SECTION 23.6: Adjust Gap between the Strike End of Door and the Jamb Tube

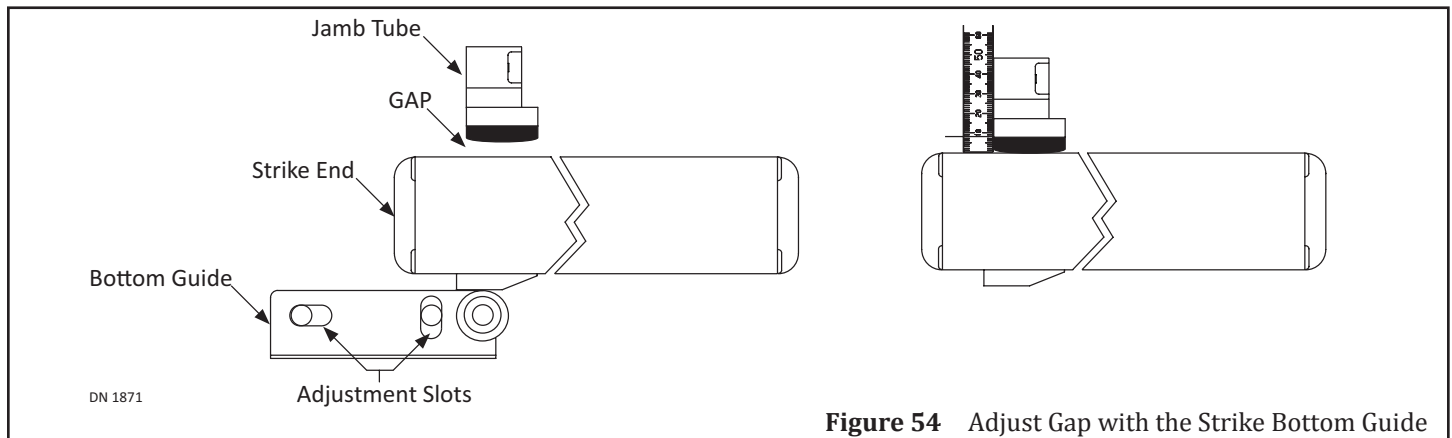

Figure 54 Adjust Gap with the Strike Bottom Guide

1. Remove the Bottom Guide Cover. Loosen (2) M5x20 Washer Head Screws.
2. Slide the Bottom Guide (up/down, to right or to the left) within the slots until the excess gap no longer exists.
3. Measurement between where the Vinyl Seal starts to protrude from the Jamb Tube; to the surface of Slide Door:
 - ▶ Does not exceed .314 inch (+.0787" / - .0393"); 8mm (+2/-1mm).
4. Tighten (2) M5x20 Washer Head Screws and replace the Cover.

SECTION 23.7: Adjust Gap between the Trail End of Door and the Jamb Tube

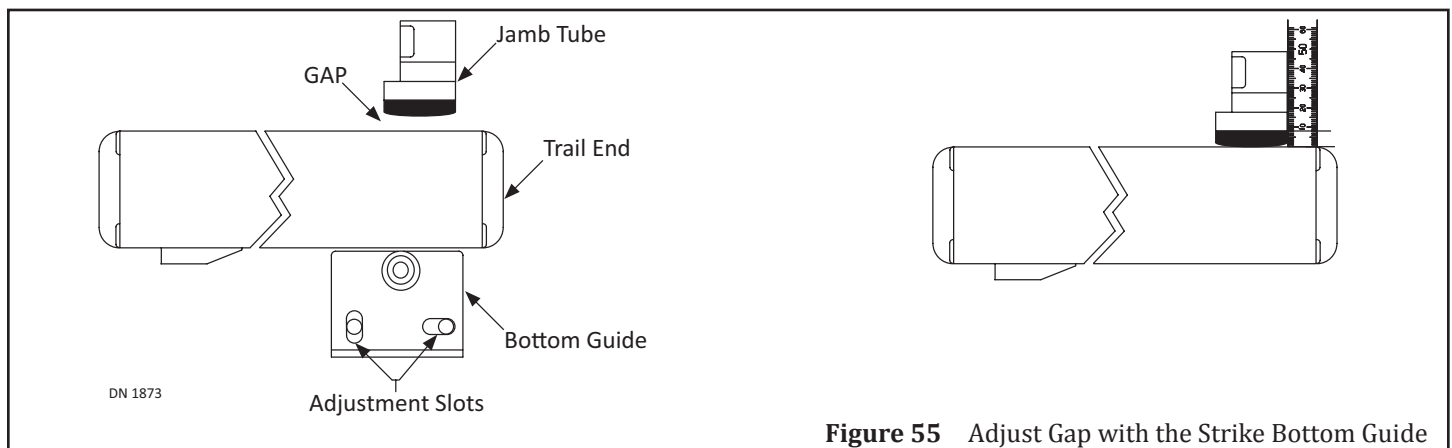

Figure 55 Adjust Gap with the Strike Bottom Guide

1. Loosen (2) M5x20 Washer Head Screws.
2. Slide the Bottom Guide (up/down, to right or to the left) within the slots until the excess gap no longer exists.
3. Measurement between where the Vinyl Seal starts to protrude from the Jamb Tube; to the surface of Slide Door:
 - a. Does not exceed .314 inch (+.0787" / - .0393"); 8mm (+2/-1mm).
 - b. Insert a credit card. If the credit card drops out between the Vinyl seal and Jamb Tube, adjustments must be made.
 - c. There must not be any GAPS.
4. Tighten (2) M5x20 Washer Head Screws.

CHAPTER 24: WEATHERING

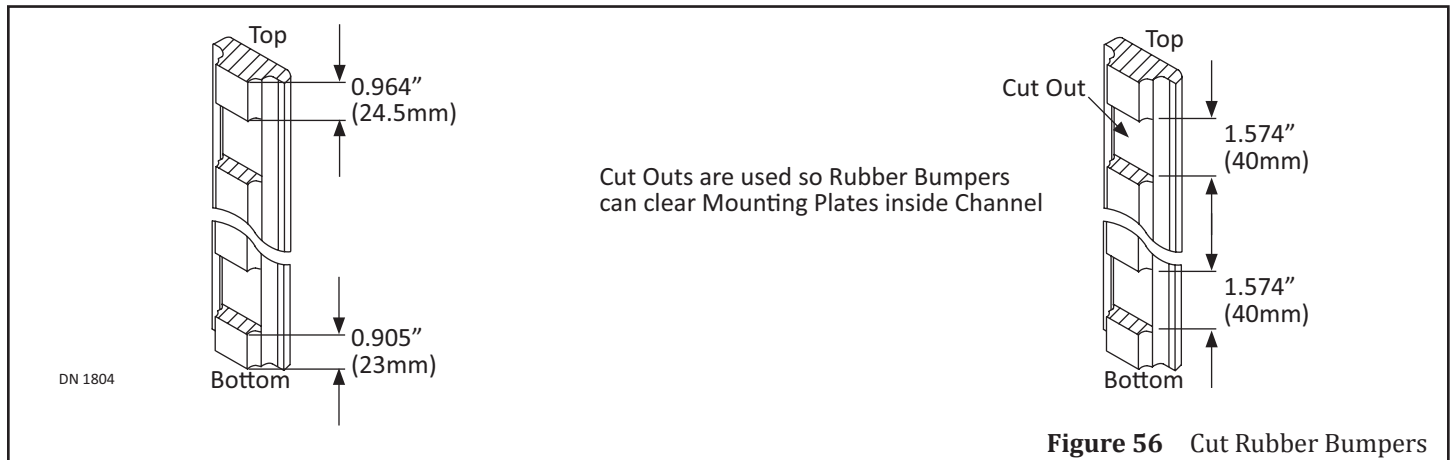

Figure 56 Cut Rubber Bumpers

SECTION 24.1: Replace Rubber Bumpers

1. Remove the Slide Door, and the Rubber Bumpers.
 - a. The Slide Door can stay hung as long as it is secured with a wedge, etc, so that it will not move.
2. Clean Channels that run up/down the Slide door. Do Not leave any residue.
3. Obtain the Rubber Bumper. The full length of the Back Side has Cut Outs to clear Mounting Plates inside each Channel.
4. Cut each Rubber Bumper so it is the same length as each Channel. In doing so, ensure the:
 - ▶ Top of Channel is 0.964" (25.5mm) solid.
 - ▶ Bottom of Channel is 0.905" (23mm) solid.

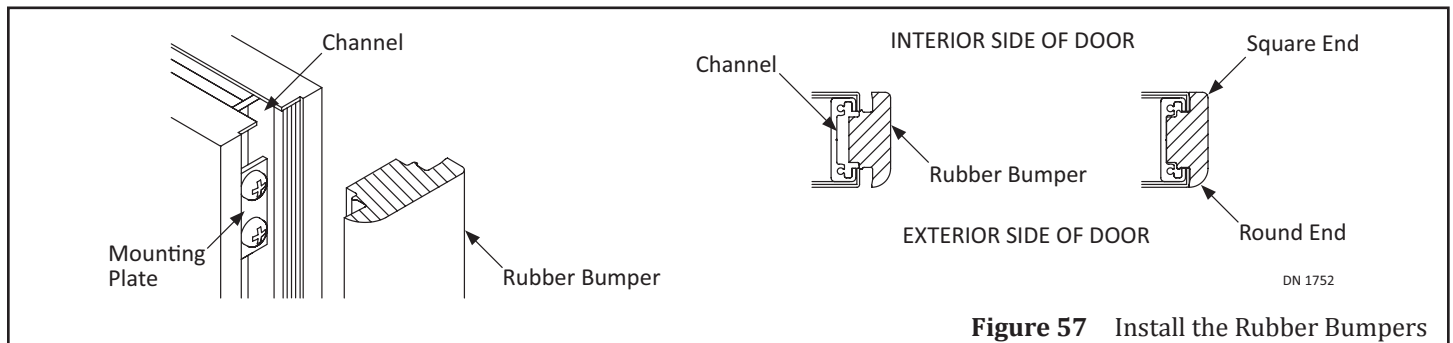

Figure 57 Install the Rubber Bumpers

Attention: Insert each Rubber Bumper so the rounded end is on the Exterior side of door. The squared end must always be on the Interior side of door.

5. Peel off the paper strip to expose the adhesive portion of tape. With the Rounded End on the Exterior side of door, push each Rubber Bumper into each Channel. A flat head screwdriver may help the insertion process.
 - a. Ensure the Rubber Bumper is completely installed with no air pockets, or crimps, etc.
6. Install the Slide Door (if removed).

SECTION 24.2: Replace Vinyl Seals on Jamb Tubes

1. Remove the Slide Door.
2. Remove the Vinyl Seal from each Jamb Tube.
3. Clean the Channels. Do Not leave any residue.

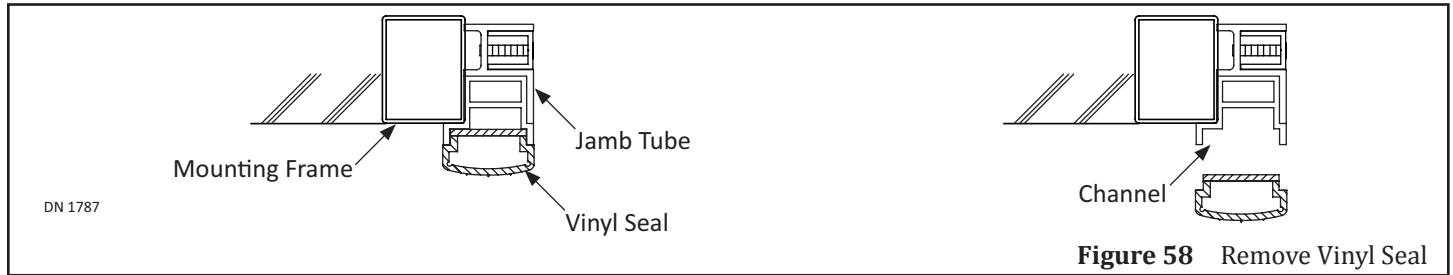
**Figure 58** Remove Vinyl Seal

4. Measure to cut the Vinyl Seal to appropriate length.

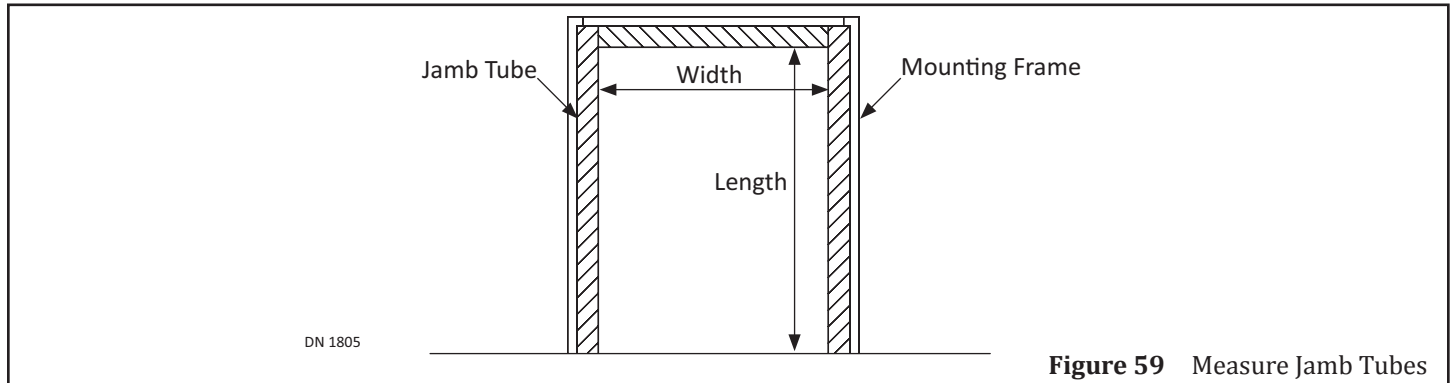
**Figure 59** Measure Jamb Tubes

5. Peel off the paper strip to expose the adhesive portion of tape. Push (1) Vinyl Seal into Channel.
 - a. Use a Flat Head screwdriver, etc.
 - b. Ensure the Vinyl Seal is completely installed with no air pockets, or crimps, etc.
6. Install the Slide Door.

SECTION 24.3: Replace Vinyl Seals on Bottom of Door

1. Remove the Slide Door.
2. Place the Slide Door on a flat surface. Protect Door from scratches.
3. Remove (1) Screw from the Mounting Bracket located inside each end of the Vinyl Seal.
4. Remove the Vinyl Seal from the Channel.

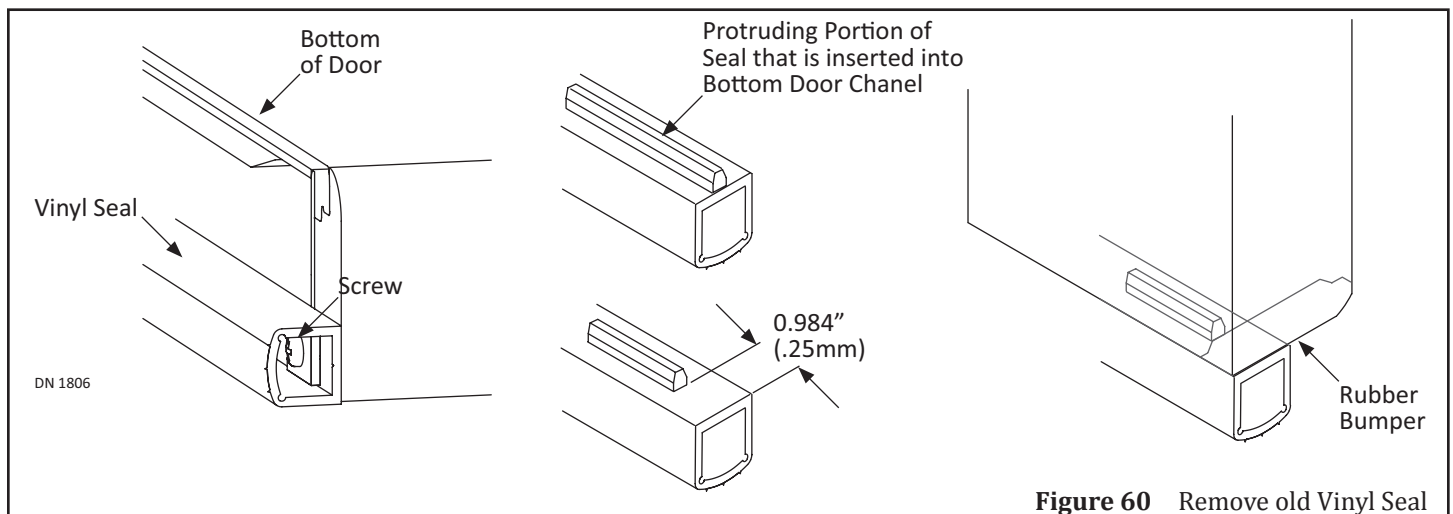
**Figure 60** Remove old Vinyl Seal

5. Measure the width of Slide Door, at the bottom. Add 0.787 inches (20mm): $\text{Width} + 0.787" = \text{Vinyl Length}$
6. Go to each edge of the Vinyl Seal. Measure 0.984 inch (25mm) towards the center. Cut off the protruding, top portion of the Vinyl Seal.
 - a. This is done so the top face of the Vinyl Seal can be flush against the bottom of each Rubber Bumper.



7. Go to each edge of the Vinyl Seal. Measure 0.787 inch (20mm) towards the center. Mark that spot.
8. Cut a cross-shaped slit no bigger than 0.196 inch (5mm).
 - a. The slit is created for (1) Screw Hole.
9. Push the protruding portion of the Vinyl Seal into the Channel.
 - a. Use a Flat Head screwdriver, etc.
 - b. Ensure the Vinyl Seal is completely installed with no air pockets, or crimps, etc
10. Secure the Vinyl Seal to each Mounting Bracket with (1) screw.

CHAPTER 25: TROUBLESHOOTING

Door does not open.	Sensor not functioning properly.	Check wire connections on Sensor Short-circuit the Sensor, and confirm that the Door closes.
The door does not close.	Sensor not functioning properly.	Check wire connections on Sensor. Remove the sensor. Confirm that the door closes.
Door movement not smooth.	Rated power is not supplied. Horizontal resistance is large.	Supply the Rated power.
The door does not Fully close (Leaves a gap).	The spring force is too strong. The contact between packings is too tight.	Adjust the inclination of the door. Check the specifications (mass) of the door system.
When Door is in Fully Closed position, power is turned OFF, and the Door opens.	Spring Force is too strong.	Loosen the spring force on the Spring Mechanism.
It is too hard to manually open the Door.	Spring Force is not strong enough.	Tighten the spring force on the Spring Mechanism. Reposition the Spring Mechanism.
The Close-Safety (reverse opening movement) occurs when the Spring Mechanism comes into contact with the Spring Mechanism Receiver.	Spring Force is too strong. Receiver is in the wrong position.	If Close-Safety occurs immediately after the Spring Mechanism butts against the Receiver, slide the Receiver towards the Strike End Cap.
The Close-Safety (reverse opening movement) occurs when the door is running on the slope of Track.	Spring Force is too strong. Receiver is in the wrong position.	Loosen the spring force on the Spring Mechanism.

CHAPTER 26: CONVERSION CHART

Accurate measurements during installation of the NAX Hermetic Slide Door are critical. Please refer to the following Conversion Chart if more detailed information is necessary to complete installation.

- ▶ Kilogram (kg) is the Standard International (SI) System of Units of mass. Where pounds denote weight, Kilograms denote mass, the force a mass exerts against a barrier in the presence of an acceleration field acting perpendicular to the barrier.
- ▶ (1) inch = (2.54) centimeters = 25.4 millimeters = .0254 meter
- ▶ (1) foot = (12) inches = (30.48) centimeters = 304.8 millimeters = 0.03048 meters
- ▶ (12 inches = 1 foot) conversely (1000 millimeters = 1 meter)

Fraction	Decimal	mm
1/64	0.0156	0.3969
1/32	0.0313	0.7938
3/64	0.0469	1.1906
1/16	0.0625	1.5875
5/64	0.0781	1.9844
3/32	0.0938	2.3813
7/64	0.1094	2.7781
1/8	0.1250	3.1750
9/64	0.1406	3.5719
5/32	0.1563	3.9688
11/64	0.1719	4.3656
3/16	0.1875	4.7625
13/64	0.2031	5.1594
7/32	0.2188	5.5563
15/64	0.2344	5.9531
1/4	0.2500	6.3500
17/64	0.2656	6.7469
9/32	0.2813	7.1438
19/64	0.2969	7.5406
5/16	0.3125	7.9375
21/64	0.3281	8.3344
11/32	0.3438	8.7313
23/64	0.3594	9.1281
3/8	0.3750	9.5250
25/64	0.3906	9.9219
13/32	0.4063	10.3188
27/64	0.4219	10.7156
7/16	0.4375	11.1125
29/64	0.4531	11.5094
15/32	0.4688	11.9063
31/64	0.4844	12.3031
1/2	0.5000	12.7000
33/64	0.5156	13.0969
17/32	0.5313	13.4938
35/64	0.5469	13.8906

Fraction	Decimal	mm
1-1/64	1.0156	25.7969
1-1/32	1.0313	26.1938
1-3/64	1.0469	26.5906
1 1/16	1.0625	26.9875
1 5/64	1.0781	27.3844
1 3/32	1.0938	27.7813
1 7/64	1.1094	28.1781
1 1/8	1.1250	28.5750
1 9/64	1.1406	28.9719
1 5/32	1.1563	29.3688
1 11/64	1.1719	29.7656
1 3/16	1.1875	30.1625
1 13/64	1.2031	30.5594
1 7/32	1.2188	30.9563
1 15/64	1.2344	31.3531
1 1/4	1.2500	31.7500
1 17/64	1.2656	32.1469
1 9/32	1.2813	32.5438
1 19/64	1.2969	32.9406
1 5/16	1.3125	33.3375
1 21/64	1.3281	33.7344
1 11/32	1.3438	34.1313
1 23/64	1.3594	34.5281
1 3/8	1.3750	34.9250
1 25/64	1.3906	35.3219
1 13/32	1.4063	35.7188
1 27/64	1.4219	36.1156
1 7/16	1.4375	36.5125
1 29/64	1.4531	36.9094
1 15/32	1.4688	37.3063
1 31/64	1.4844	37.7031
1 1/2	1.5000	38.1000
1 33/64	1.5156	38.4969
1 17/32	1.5313	38.8938
1 35/64	1.5469	39.2906

Fraction	Decimal	mm
2-1/64	2.0156	51.1969
2-1/32	2.0313	51.5938
2-3/64	2.0469	51.9906
2 1/16	2.0625	52.3875
2 5/64	2.0781	52.7844
2 3/32	2.0938	53.1813
2 7/64	2.1094	53.5781
2 1/8	2.1250	53.9750
2 9/64	2.1406	54.3719
2 5/32	2.1563	54.7688
2 11/64	2.1719	55.1656
2 3/16	2.1875	55.5625
2 13/64	2.2031	55.9594
2 7/32	2.2188	56.3563
2 15/64	2.2344	56.7531
2 1/4	2.2500	57.1500
2 17/64	2.2656	57.5469
2 9/32	2.2813	57.9438
2 19/64	2.2969	58.3406
2 5/16	2.3125	58.7375
2 21/64	2.3281	59.1344
2 11/32	2.3438	59.5313
2 23/64	2.3594	59.9281
2 3/8	2.3750	60.3250
2 25/64	2.3906	60.7219
2 13/32	2.4063	61.1188
2 27/64	2.4219	61.5156
2 7/16	2.4375	61.9125
2 29/64	2.4531	62.3094
2 15/32	2.4688	62.7063
2 31/64	2.4844	63.1031
2 1/2	2.5000	63.5000
2 33/64	2.5156	63.8969
2 17/32	2.5313	64.2938
2 35/64	2.5469	64.6906

Fraction	Decimal	mm
9/16	0.5625	14.2875
37/64	0.5781	14.6844
19/32	0.5938	15.0813
39/64	0.6094	15.4781
5/8	0.6250	15.8750
41/64	0.6406	16.2719
21/32	0.6563	16.6688
43/64	0.6719	17.0656
11/16	0.6875	17.4625
45/64	0.7031	17.8594
23/32	0.7188	18.2563
47/64	0.7344	18.6531
3/4	0.7500	19.0500
49/64	0.7656	19.4469
25/32	0.7813	19.8438
51/64	0.7969	20.2406
13/16	0.8125	20.6375
53/64	0.8281	21.0344
27/32	0.8438	21.4313
55/64	0.8594	21.8281
7/8	0.8750	22.2250
57/64	0.8906	22.6219
29/32	0.9063	23.0188
59/64	0.9219	23.4156
15/16	0.9375	23.8125
61/64	0.9531	24.2094
31/32	0.9688	24.6063
63/64	0.9844	25.0031
1	1.0000	25.4000

Fraction	Decimal	mm
1 9/16	1.5625	39.6875
1 37/64	1.5781	40.0844
1 19/32	1.5938	40.4813
1 39/64	1.6094	40.8781
1 5/8	1.6250	41.2750
1 41/64	1.6406	41.6719
1 21/32	1.6563	42.0688
1 43/64	1.6719	42.4656
1 11/16	1.6875	42.8625
1 45/64	1.7031	43.2594
1 23/32	1.7188	43.6563
1 47/64	1.7344	44.0531
1 3/4	1.7500	44.4500
1 49/64	1.7656	44.8469
1 25/32	1.7813	45.2438
1 51/64	1.7969	45.6406
1 13/16	1.8125	46.0375
1 53/64	1.8281	46.4344
1 27/32	1.8438	46.8313
1 55/64	1.8594	47.2281
1 7/8	1.8750	47.6250
1 57/64	1.8906	48.0219
1 29/32	1.9063	48.4188
1 59/64	1.9219	48.8156
1 15/16	1.9375	49.2125
1 61/64	1.9531	49.6094
1 31/32	1.9688	50.0063
1 63/64	1.9844	50.4031
2	2.0000	50.8000

Fraction	Decimal	mm
2 9/16	2.5625	65.0875
2 37/64	2.5781	65.4844
2 19/32	2.5938	65.8813
2 39/64	2.6094	66.2781
2 5/8	2.6250	66.6750
2 41/64	2.6406	67.0719
2 21/32	2.6563	67.4688
2 43/64	2.6719	67.8656
2 11/16	2.6875	68.2625
2 45/64	2.7031	68.6594
2 23/32	2.7188	69.0563
2 47/64	2.7344	69.4531
2 3/4	2.7500	69.8500
2 49/64	2.7656	70.2469
2 25/32	2.7813	70.6438
2 51/64	2.7969	71.0406
2 13/16	2.8125	71.4375
2 53/64	2.8281	71.8344
2 27/32	2.8438	72.2313
2 55/64	2.8594	72.6281
2 7/8	2.8750	73.0250
2 57/64	2.8906	73.4219
2 29/32	2.9063	73.8188
2 59/64	2.9219	74.2156
2 15/16	2.9375	74.6125
2 61/64	2.9531	75.0094
2 31/32	2.9688	75.4063
2 63/64	2.9844	75.8031
3	3.0000	76.2000

Source: Maryland Metrics (mdmetric.com)

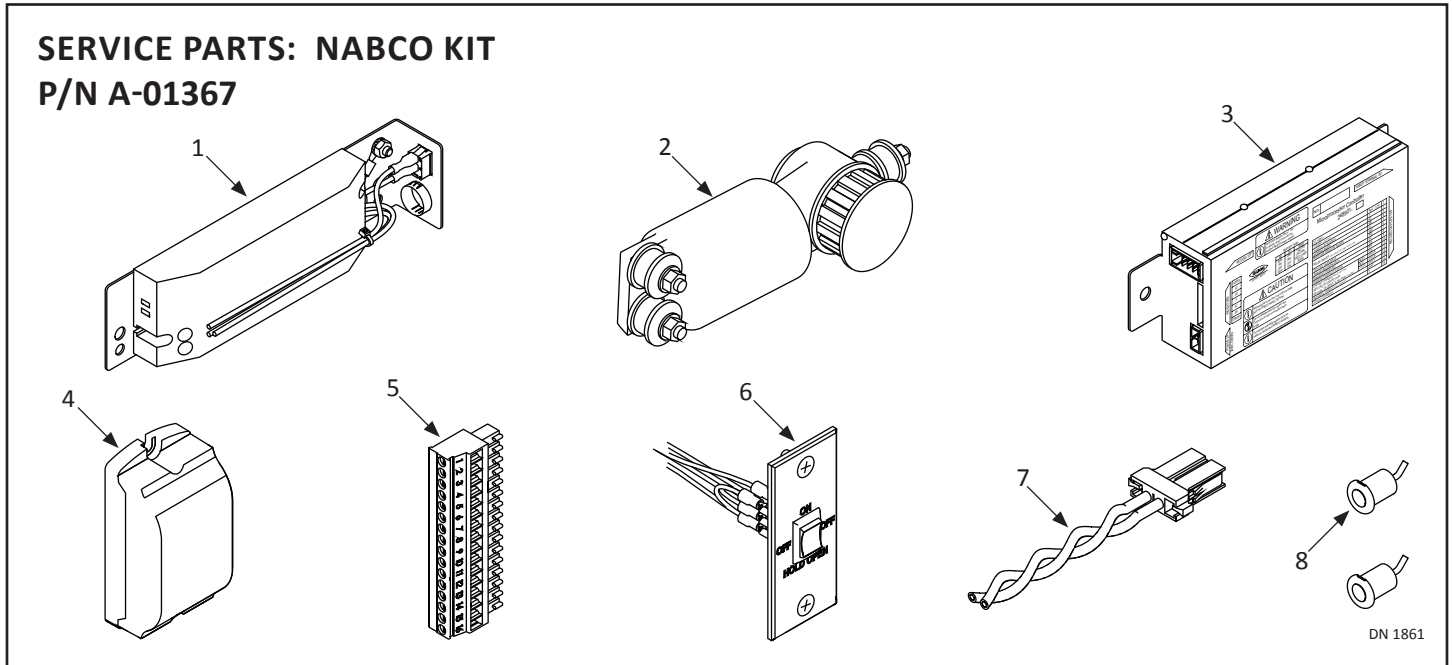

Service Parts Kit				
Item	Part	Used To	Description	
1	A-00717	Supply Power to Control and Motor/Operator	POWER SUPPLY,27 VDC,100 WATT	
2	M-00395	Control Operation of Door	OPERATOR,DS150	
3	V-00020	Program Function of Door	CONTROLLER, U30	
4	A-00129	Hold Door Open. Activated by Holding Beams	AMPLIFIER, PHOTOEYE, OPTEX ASSY	
5	V-00410	Hardwire Components within Header to Control	TERMINAL BLOCKU30 WIRE CONNECTOR	
6	A-00805	Turn Power On or Off	SWITCH, ROCKER,SWINGER,ON/OFF/HOLD OPEN	
7	M-00412	Connect Operator to the Motor Operator	HARNESS,U30,POWER	
8	V-00073	Sense/Activate the Photoeye Amplifier when a pedestrian crosses or stands within the threshold.	HOLDING BEAM,PHOTO ELECTRIC,W/ EXT CABLE	

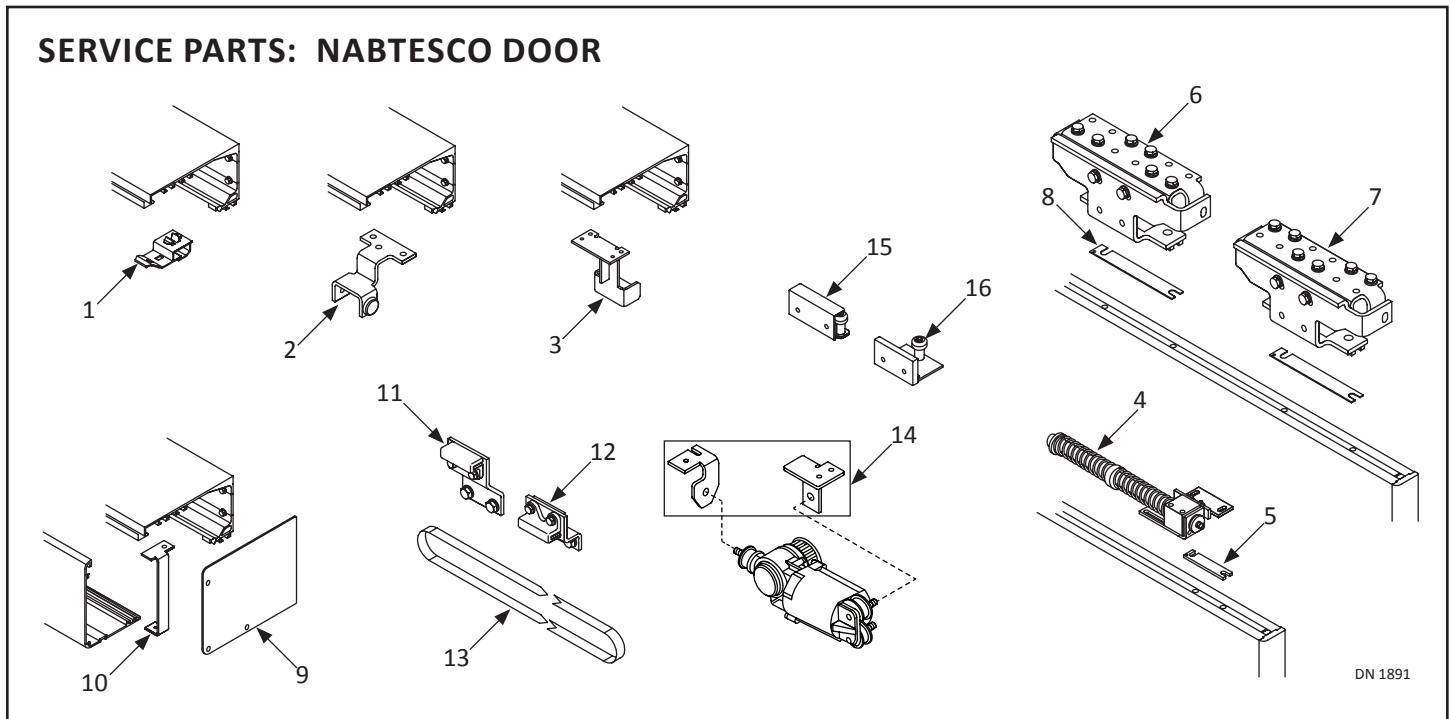

NABTESCO Service Parts			
Item	Part	Finish/Sizes/Notes	Description
1	5927-3182459-01		WIRE SUPPORT CLIP
2	5443-3184685-02	RH	DOOR STOPPER, R
	5443-3184685-01	LH	DOOR STOPPER, L
3	5443-3185118-02	RH/with Tape	SPRING MECHANISM RECEIVER, WITH TAPE R
	5443-3185118-01	LH/with Tape	SPRING MECHANISM RECEIVER, WITH TAPE L
4	5411-3184705-03	RH/Lightweight	NAX SPRING MECHANISM, R, LIGHTWEIGHT DOOR
	5411-3184705-04	LH/Lightweight	NAX SPRING MECHANISM, L, LIGHTWEIGHT DOOR
	5411-3184705-02	For BiPart Door/NonHanded/Heavy	NAX SPRING MECHANISM, L, HEAVY DOOR
5	5843-4184701-01	Use with Spring Mechanism	DOOR HANGER SPACER 2
6	5431-3184889-01		NAX DOOR HANGER, A
7	5431-3184889-02		NAX DOOR HANGER, B
8	5843-4184700-01	Use with Door Hanger	DOOR HANGER SPACER 1
9	5459-4184658-01		END CAP
	5459-4184658-11	Other Color	END CAP
10	5443-4184721-01		FRONT COVER BRACKET
11	5443-3184690-01	Single Sliding	BELT CLIP, SINGLE
12	5443-3184697-01	BiPart	BELT CLIP, BIPART
13	5821-3110719-04		DRIVE BELT 150S8M L=6072
	5821-3110719-03		DRIVE BELT 150S8M L=3056
14	5443-4184692-01		GEARED MOTOR BRACKET SET
15	5431-3184498-02	RH/Strike side of Door	GUIDE ROLLER CP, R, LEADING
	5431-3184498-01	LH/Strike side of Door	GUIDE ROLLER CP, L, LEADING
16	5431-3184499-02	RH/Trail side of Door	GUIDE ROLLER CP, R, TRAILING
	5431-3184499-01	LH/Trail side of Door	GUIDE ROLLER CP, L, TRAILING