



Model GT1500 Convenience Window Installation Manual

\*\*with U30 Control\*\*

P/N C-00287 Rev 1-5-18

Nabco Entrances Inc. S82 W18717 Gemini Drive Muskego, Wisconsin 53150
Phone: (877) 622-2694 Fax: (888) 679-3319 www.nabcoentrances.com
NABCO hours of Operation: Monday to Friday 8:00 a.m.- 4:30 p.m. (Central Time)

Associated Manuals Part Numbers: GT1500 Convenience Window Owner's Manual; P/N C-00318
U30 Microprocessor Control Setup and Programming Manual; Rev "E"; P/N C-00203

WARNING

- Turn OFF all power to the Automatic Window if a Safety System is not working.
• Instruct the Owner to keep all power turned OFF until corrective action can be achieved by a NABCO trained technician. Failure to follow these practices may result in serious consequences.
• NEVER leave a Window operating without all Safety Detection Systems operational.

Table of Contents

CHAPTER 1: WARNING LABELS 3
CHAPTER 2: GENERAL SAFETY RECOMMENDATIONS 3
CHAPTER 3: SCOPE 4
SECTION 3.1: To the Installer 4
SECTION 3.2: Objective 4
CHAPTER 4: GETTING STARTED 4
SECTION 4.1: Mechanical Configurations 4
SECTION 4.2: Electrical Standards 4
SECTION 4.3: Anchors and Fasteners 4
SECTION 4.4: Handling of Glass 4
CHAPTER 5: PREPARE THE ROUGH OPENING 4
CHAPTER 6: PREPARE THE HEADER 5
CHAPTER 7: INSTALL THE "MANUAL" WINDOW 5
SECTION 7.1: Shim and Plumb the Window 5
SECTION 7.2: Secure Jamb Tubes and Header to Opening 6
CHAPTER 8: INSTALL THE "AUTOMATIC" WINDOW 7
SECTION 8.1: Route 120 VAC Wiring into the Drive Jamb Tube 7
SECTION 8.2: Shim and Plumb the Window 8
SECTION 8.3: Secure Jamb Tubes and Header to Opening 9
CHAPTER 9: 120 VAC GENERAL WIRING 12

**CHAPTER 10: GENERAL WIRING ..... 13**

**CHAPTER 11: WEATHERING ..... 14**

**CHAPTER 12: COMMON SERVICE PARTS ..... 14**

## CHAPTER 1: WARNING LABELS

Warning labels are universal and used to alert an individual of potential harm to one's self or to others. The following warning labels are listed in a hierarchy order that defines the most potential danger first, and the least potential danger last. Please refer to this page in the event that a warning label is displayed within this manual and further definition needs to be explained.

**DANGER** Indicates potentially dangerous situations. Danger is used when there is a hazardous situation where there is a *high* probability of severe injury or death. It should not be considered for property damage unless personal injury risk is present.

**WARNING** Indicates a hazardous situation which has *some* probability of severe injury. It should not be considered for property damage unless personal injury risk is present.

**CAUTION** Indicates a hazardous situation which *may result in a minor injury*. Caution should not be used when there is a possibility of serious injury. Caution should not be considered for property damage accidents unless a personal injury risk is present.

**Attention:** A situation where material could be damaged or the function impaired.

**Notice:** Indicates a statement of company policy as the message relates to the personal safety or protection of property. Notice should not be used when there is a hazardous situation or personal risk.

*Note:* Indicates important information that provides further instruction.

## CHAPTER 2: GENERAL SAFETY RECOMMENDATIONS

**WARNING** Do not install, operate or service this product unless you have read and understand the General Safety Recommendations, Warning Labels, contained in this manual. Failure to do so may result in bodily injury, or property damage.

**WARNING** Read, study and understand the installation and operating instructions contained in, or referenced in this manual before operating. If you do not understand the instruction, ask a qualified technician. Failure to do so may result in bodily injury, or property damage and will nullify all warranties.

**DANGER** Disconnect all power to the junction box prior to making any electrical connections. Failure to do so may result in serious personal or fatal injury. When uncertain whether power supply is disconnected, always verify using a voltmeter.

**DANGER** Do not place finger or uninsulated tools inside the electrical controller. Touching wires or other parts inside the enclosure may cause electrical shock, serious injury or death.

**CAUTION** The Ground wire from the U30 Control 120 VAC Harness, and the Incoming 120 VAC Ground wire must be connected to the Ground screw located within the Swing door Header.

**CAUTION** If the door appears broken or does not seem to work correctly, it should be immediately removed from service until repairs can be carried out or a qualified service technician is contacted for corrective action.

**Notice:** This manual must be given to and retained by the purchasing facility or end user.

**Notice:** Wiring must meet all local, state, federal or other governing agency codes.

**Notice:** All electrical troubleshooting or service must be performed by qualified electrical technicians and must comply with all applicable governing agency codes.

**Notice:** The GT1500 Convenience Window is preassembled at the NABCO Entrances Factory. No disassembly is required.

**Notice:** If any part of the GT1500 Convenience Window is disassembled during installation, it will be the responsibility of the Installer to return the Unit back to its original factory condition.

## CHAPTER 3: SCOPE

### SECTION 3.1: To the Installer

The purpose of this manual is to familiarize the installer and purchaser with the proper installation and operation of the Convenience Window. It is essential that this equipment be properly installed and operational before the window is used by the public. It is the purchaser's responsibility to inspect the operation of the Convenience Window to be sure it complies with any applicable standards.

Instruct the building owners/operator on the essentials of the operation of the window. The owner should follow these instructions to determine whether the window is operating properly and should immediately call for service if there is any malfunction. All installation changes and adjustments must be done by qualified, NABCO trained technicians.

### SECTION 3.2: Objective

The Convenience Window is designed to be installed within a Rough Opening of a Building, or Mounted on the Interior Surface. The automatic window function is controlled by the U30 Microprocessor Control. This control offers many features to accommodate most installation options. This manual offers step by step instructions.

## CHAPTER 4: GETTING STARTED

### SECTION 4.1: Mechanical Configurations

- ▶ Single Slide: (1) Slide Window that slides to the right or left with (1) Sidelite Panel.
- ▶ Bi-Part: (2) Slide Windows that slides apart from the center with (2) Sidelite Panels.

### SECTION 4.2: Electrical Standards

*Note: It is recommended for the Installer to use an Electrical Conduit to house all incoming 120 VAC wires.*

*Note: All wiring must conform to standard wiring practices and be in accordance with national and local electrical codes.*

Electricity	Description
Power Input	120 ( $\pm 10\%$ ) AC 50-60Hz, 5 Amps
Available wire size for incoming power	14 AWG
Current Consumption	Max. 5A
Power Output (#9DC, 12V and #7)	12 VDC 0.35 amps (350 mA) Class 2 Power Supply

### SECTION 4.3: Anchors and Fasteners

Use Anchors and Fasteners to mount the Window Frame into the Opening. The quantity and type of fasteners used, depend on the Type of material the Window Frame is being fastened to, and the size of the Window.

- ▶ Fasteners are not provided by NABCO.
- ▶ It is recommended to countersink each 1/4 inch diameter hole.
- ▶ Use an appropriate tap drill to drill a pilot hole.
- ▶ Ensure each visible screw head is flush on the face of Jamb Tubes.
- ▶ Do not overtighten fasteners to prevent deforming Jamb Tubes.
- ▶ Ensure screw heads do not come in contact with edges of glass to prevent damage.

### SECTION 4.4: Handling of Glass

Handle Glass With Care. Use caution when moving and installing the glass panels. These panels are designed to be assembled with tempered glass. Any sharp objects that come in contact with glass may cause the glass to shatter. NABCO Entrances is not responsible for glass that is broken during the installation of this Unit.

## CHAPTER 5: PREPARE THE ROUGH OPENING

1. Ensure the Rough Opening is correct size.
  - ▶ The width of the Rough Opening should equal: **PACKAGE WIDTH + 1/4 INCH ON EACH SIDE**
  - ▶ The height of the Rough Opening should equal: **PACKAGE HEIGHT + 1/4 INCH**

*Note: Make allowances for tile or other existing materials that may change the floor height.*

2. Ensure the Flat Surface is level across the entire opening.
3. Inspect the area around the rough opening. There should be no obstructions that will interfere with the installation or performance of the unit. Clean away any debris, metal chips, or caulking in and around the rough opening.

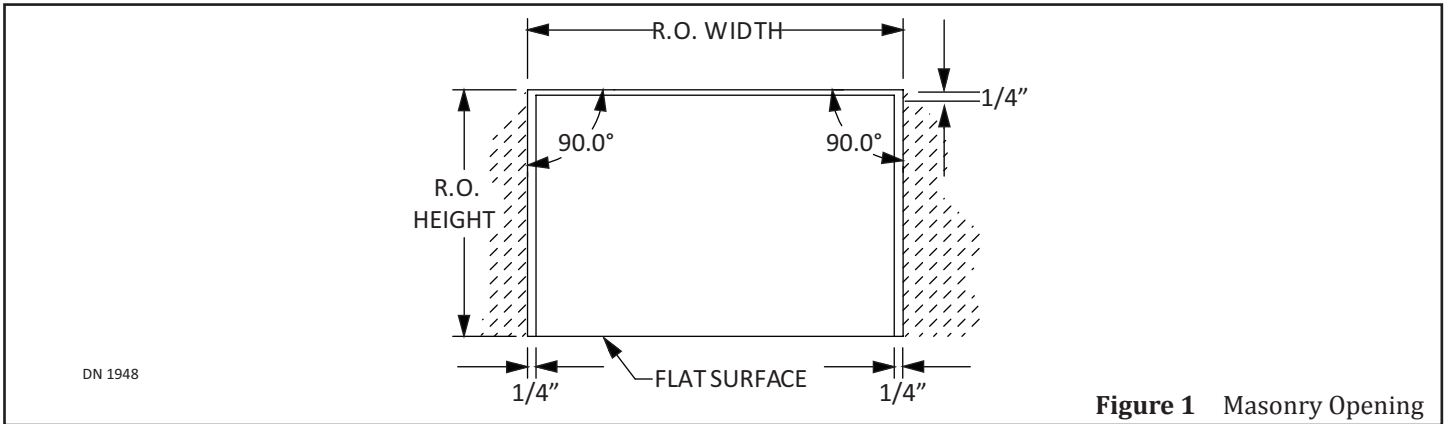

### CHAPTER 6: PREPARE THE HEADER

1. Go to Header. Open and then lift out the Cover from the Header channel.

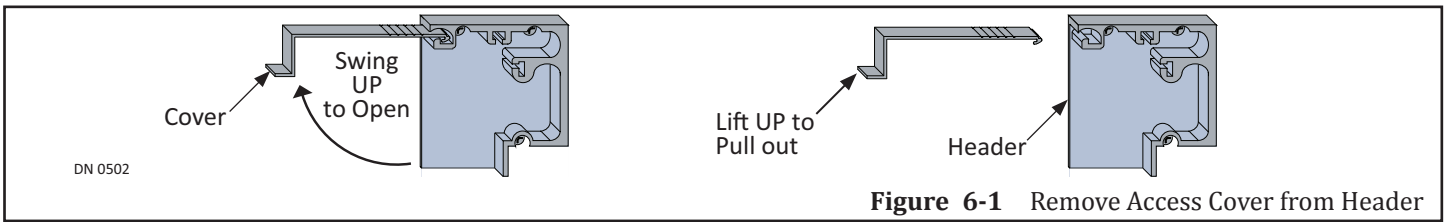

### CHAPTER 7: INSTALL THE "MANUAL" WINDOW

#### SECTION 7.1: Shim and Plumb the Window

1. Lift to position the Window into Opening so Threshold is inside the building.

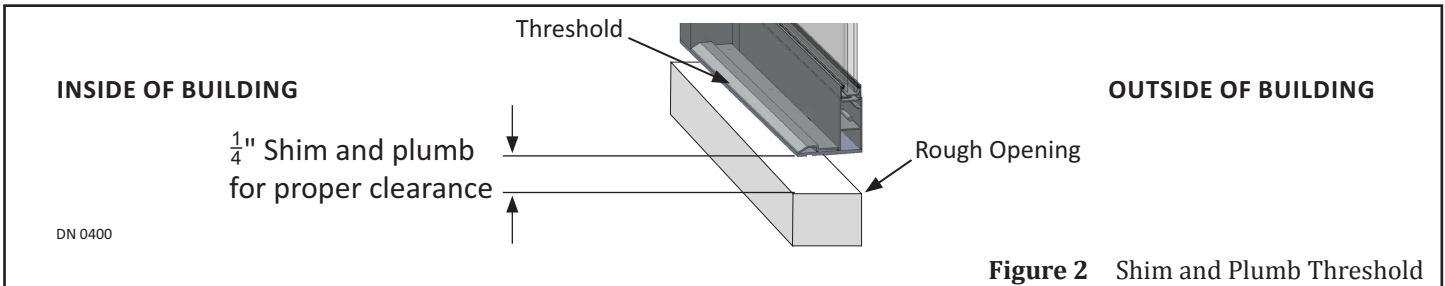

2. Plumb Threshold to ensure the Opening allows a 1/4 inch clearance. Shim as required.
3. Plumb top, and both planes of Window to ensure Opening allows 1/4 inch clearance. Shim as required.

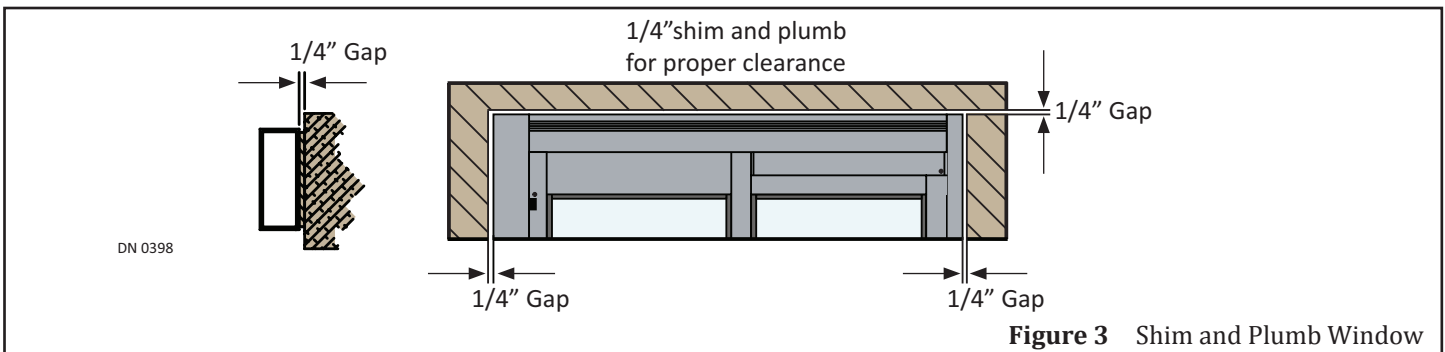

**SECTION 7.2: Secure Jamb Tubes and Header to Opening**

1. From inside the building, mark and drill a minimum of (2) evenly spaced, 1/4 inch screw holes into each Jamb Tube.
  - a. Insert (1) 1/4 inch screw into the Lock Cutout on Strike Jamb to secure Window to Opening.
2. Secure the Each Jamb Tube with 1/4 inch diameter fasteners.

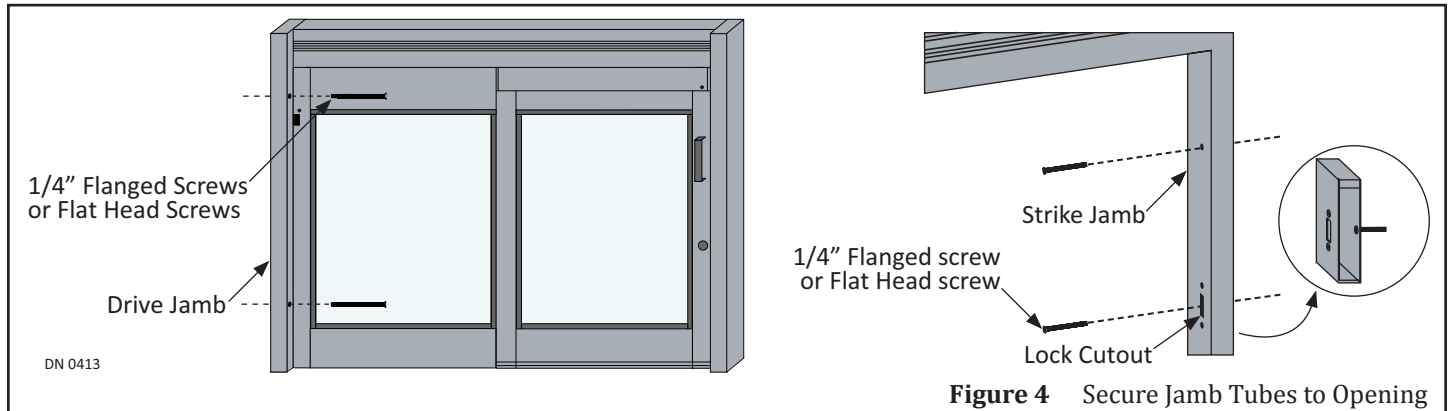

3. Go inside the Header. Mark and drill 1/4 inch screw holes in front of the Nut Chase.
4. Secure the Header with 1/4 inch diameter fasteners. Do not overtighten fasteners to prevent deforming the Header.

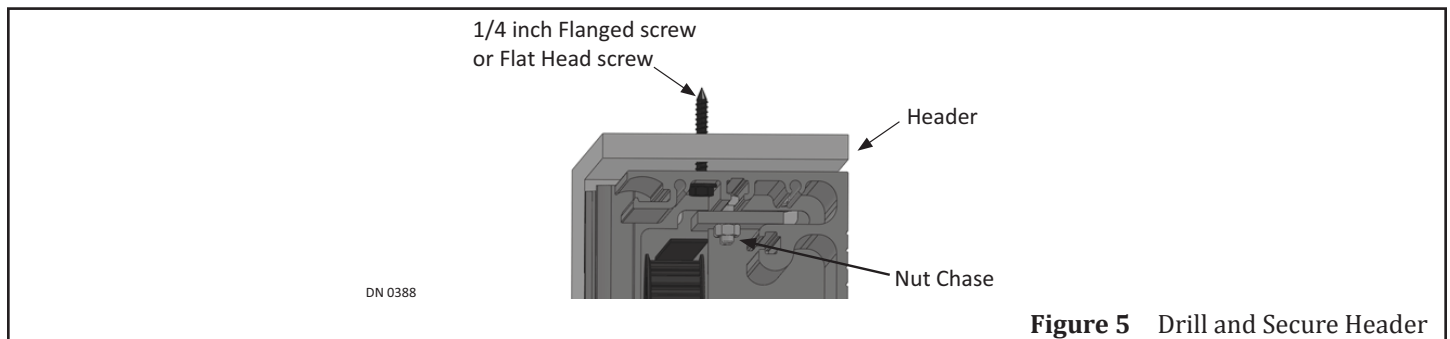

5. Go to the Threshold. Remove all Bolts used to keep the Threshold Components together. If only removing (2) Bolts, it is recommended to remove the (2) middle Bolts, or the (2) end Bolts.

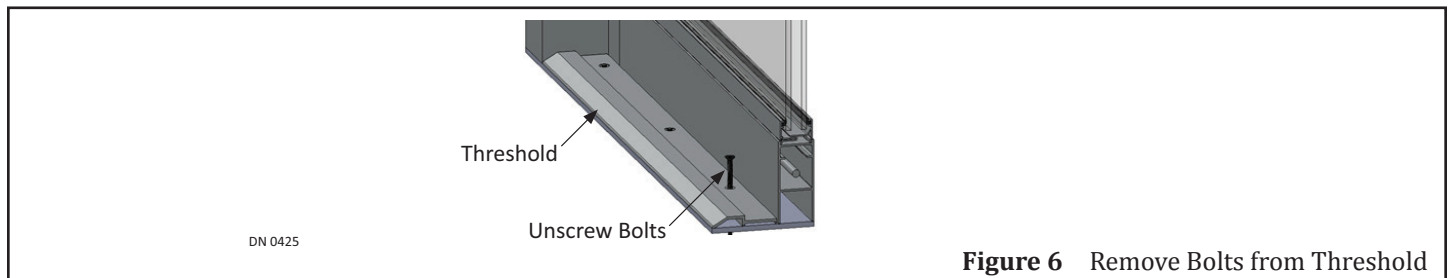

6. Drill 1/4 inch screw holes through the existing screw holes approximately 1-1/2 inch down the flat surface.

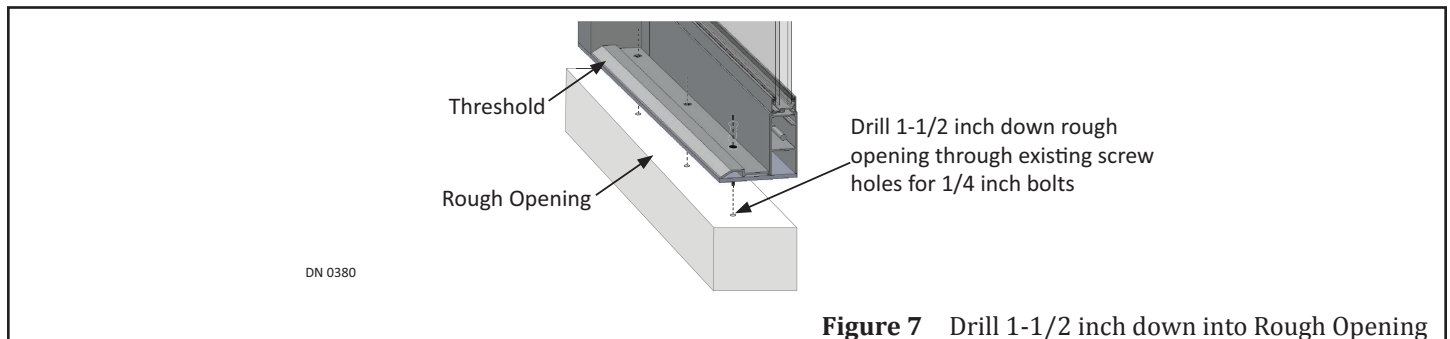

- Secure Threshold to the Opening with (1/4 x 1-1/2 inch) Flange screws or Flat Head screws.

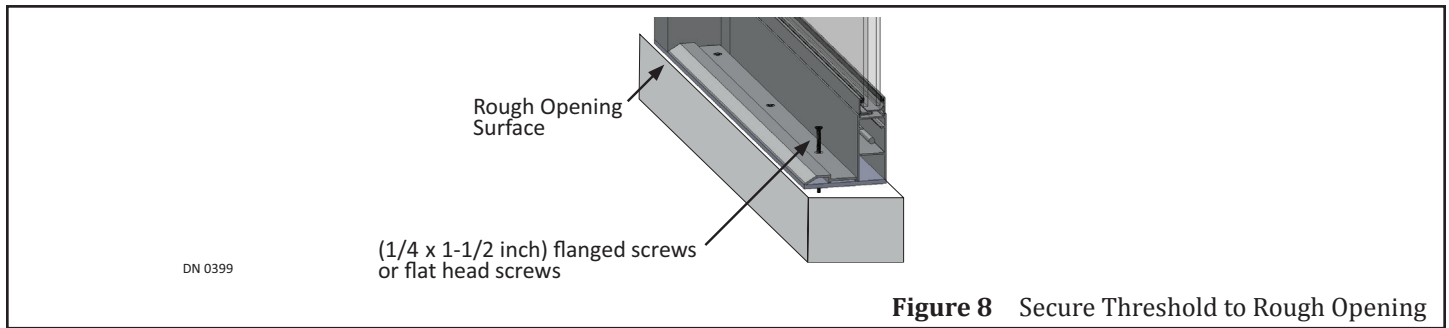

**Figure 8** Secure Threshold to Rough Opening

## CHAPTER 8: INSTALL THE “AUTOMATIC” WINDOW

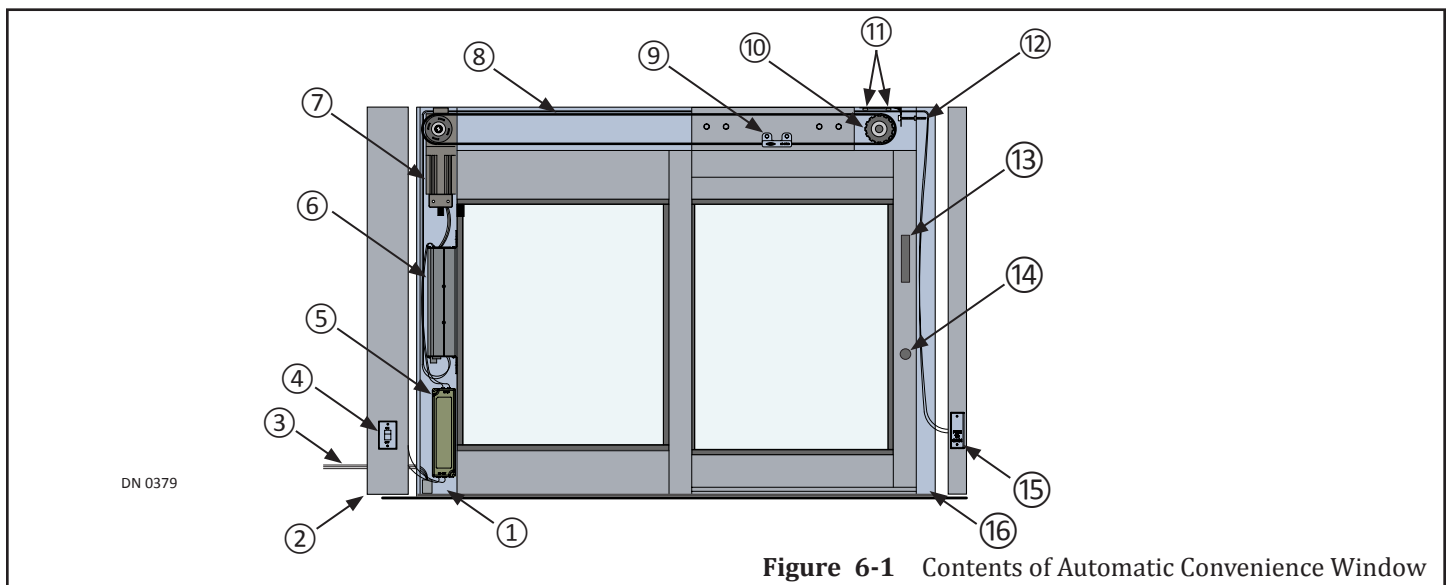
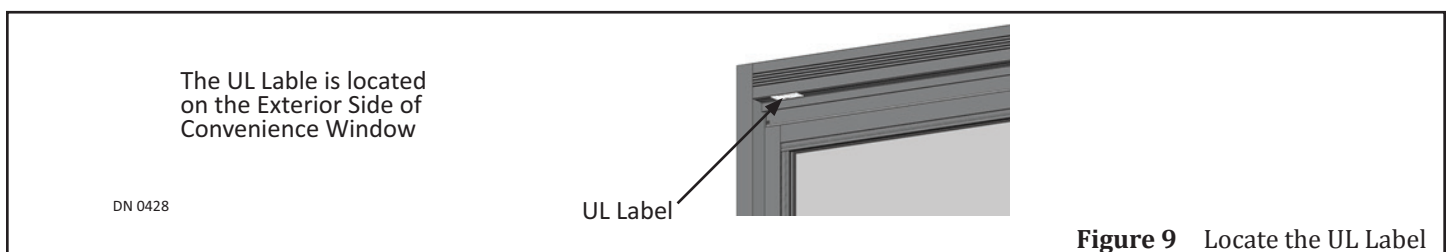

**Figure 6-1** Contents of Automatic Convenience Window

- |                                  |  |
|----------------------------------|--|
| 1. Inside Drive Jamb             | 9. Belt Clip                             |
| 2. Drive Jamb Hinged Cover       | 10. Idler Pulley                         |
| 3. Incoming 120 VAC Power Supply | 11. Locking Nuts                         |
| 4. On/Off Switch                 | 12. Belt Adjustment Bolt                 |
| 5. Power Supply                  | 13. Manual Handle                        |
| 6. Microprocessor Control        | 14. Manual Lock                          |
| 7. Motor Operator Assembly       | 15. Rocker Switch                        |
| 8. Drive Belt                    | 16. Inside Strike Jamb (No Hinged Cover) |

### SECTION 8.1: Route 120 VAC Wiring into the Drive Jamb Tube

- Locate the UL Label on the exterior side of the Convenience Window, underneath the Header, in the clear opening.



**Figure 9** Locate the UL Label

2. Inspect the location and grade of all incoming 120 VAC power cables.
3. Go to the side of Drive Jamb and remove the Dome Plug.
4. Insert all incoming 120 VAC power cables into the predrilled 7/8 inch diameter hole.
  - a. It is recommended for the installer to house all incoming 120 VAC wires within an Electrical Conduit.
  - b. The electrician and the installer must provide adequate wiring to connect all 120 VAC low voltage wires to the existing wires inside the Drive Jamb.
  - c. Do Not connect the incoming wires at this time.

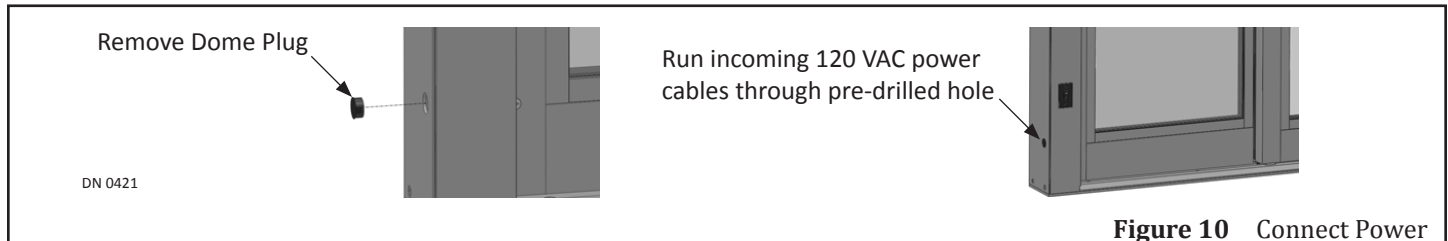

## SECTION 8.2: Shim and Plumb the Window

1. Lift to position the Window into opening so Threshold is inside the building.
2. Plumb the Threshold to ensure the opening allows a 1/4 inch clearance. Shim as required.

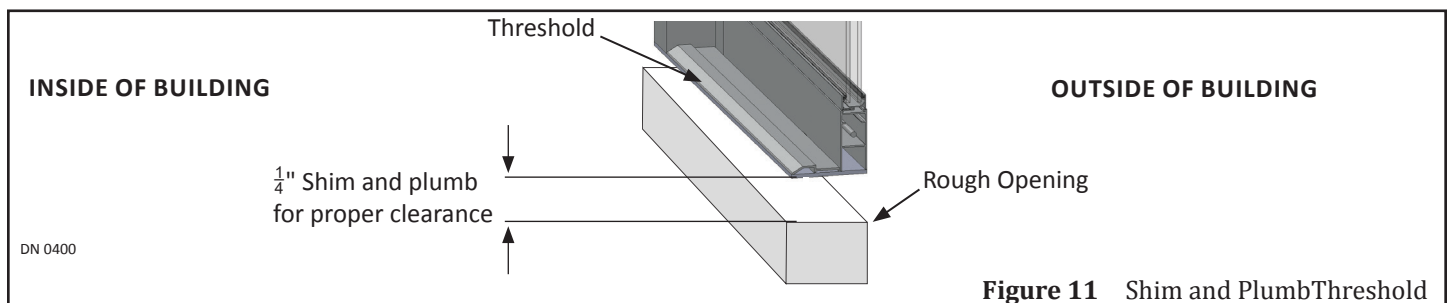

3. Plumb the top and both planes of Window to ensure opening allows 1/4 inch clearance. Shim as required.
4. Ensure that:
  - a. The entire Window fits squarely into the opening.
  - b. Both Window Panels are parallel to the exterior surface.
  - c. Jambes are plumb to the ground.

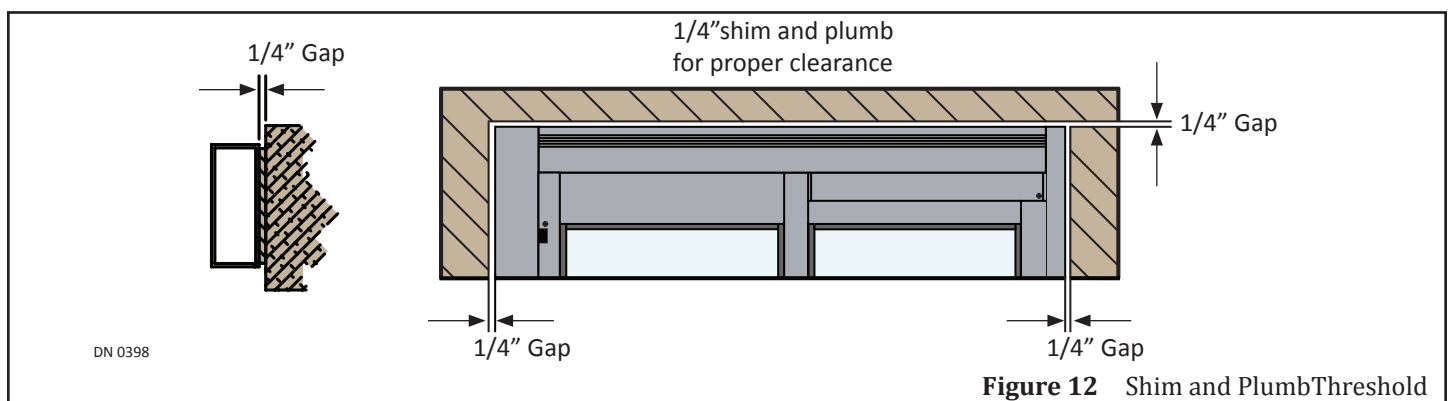

5. Go to the top of Strike Jamb.
6. Look down, into the Strike Jamb to locate (2) wires that are connected to the Push Platte.
7. Move the (2) wires so they will not be in the way while drilling holes and screwing bolts.
8. Keep the (2) wires together and tape them in place.



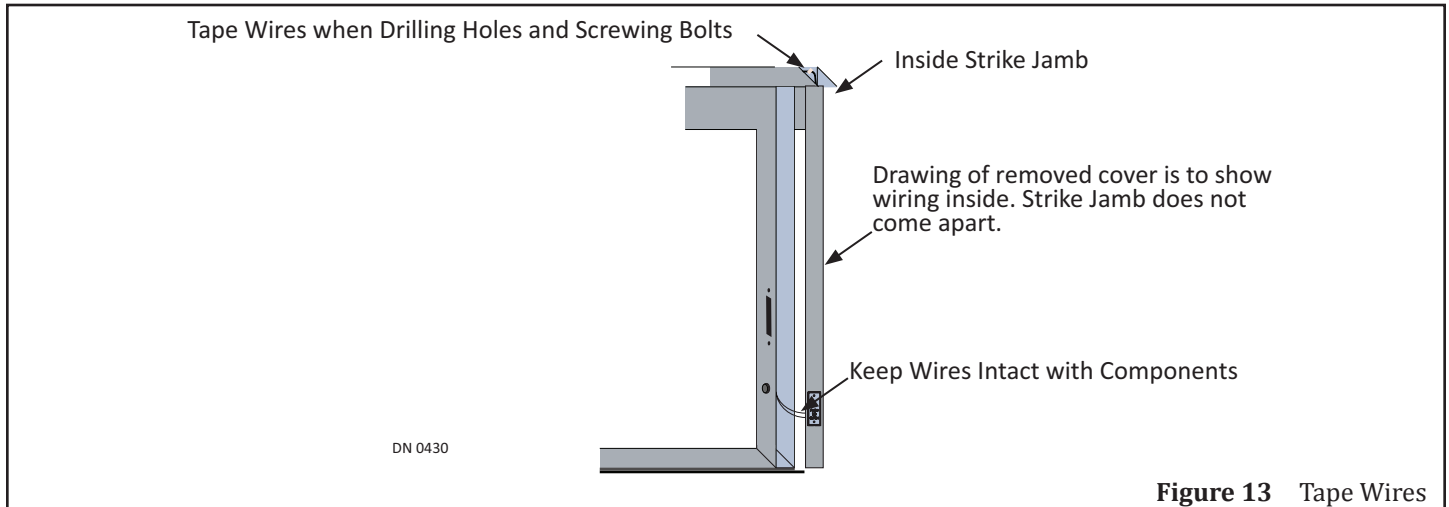

Figure 13 Tape Wires

9. Route (2) wires from inside the Strike Jamb through the Header. Ensure the (2) wires stay clear of being damaged and are concealed/taped inside the Upper Cavity of the Header.
10. Connect the (2) wires to the U-30 Microprocessor. Continue routing the (2) wires down into the Drive Jamb.

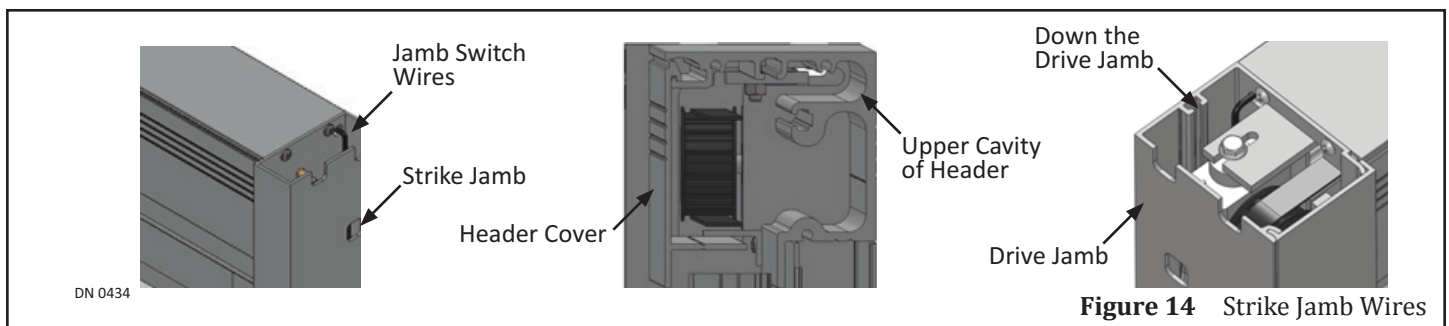

Figure 14 Strike Jamb Wires

### SECTION 8.3: Secure Jamb Tubes and Header to Opening

1. From inside the building, go to the Drive Jamb.
2. Remove the Hinged Cover Plate by opening it from the right side, and then lifting it out of the channel.

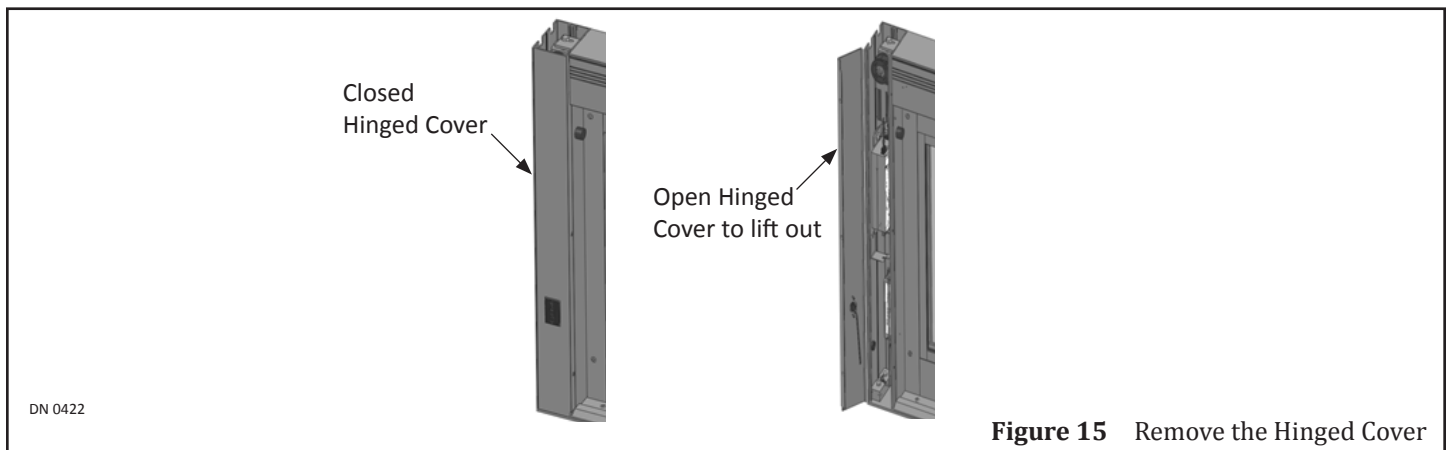

Figure 15 Remove the Hinged Cover

3. Mark and drill a minimum of (2) evenly spaced, 1/4 inch screw holes.
  - a. When moving wires, ensure to keep wires intact with components. Temporarily secure loose wires with Tape.
  - b. Do Not drill into any major components or cut wiring inside.

**Notice:** While Drilling, it is the responsibility of the Installer not to damage any Drive components or Wires.

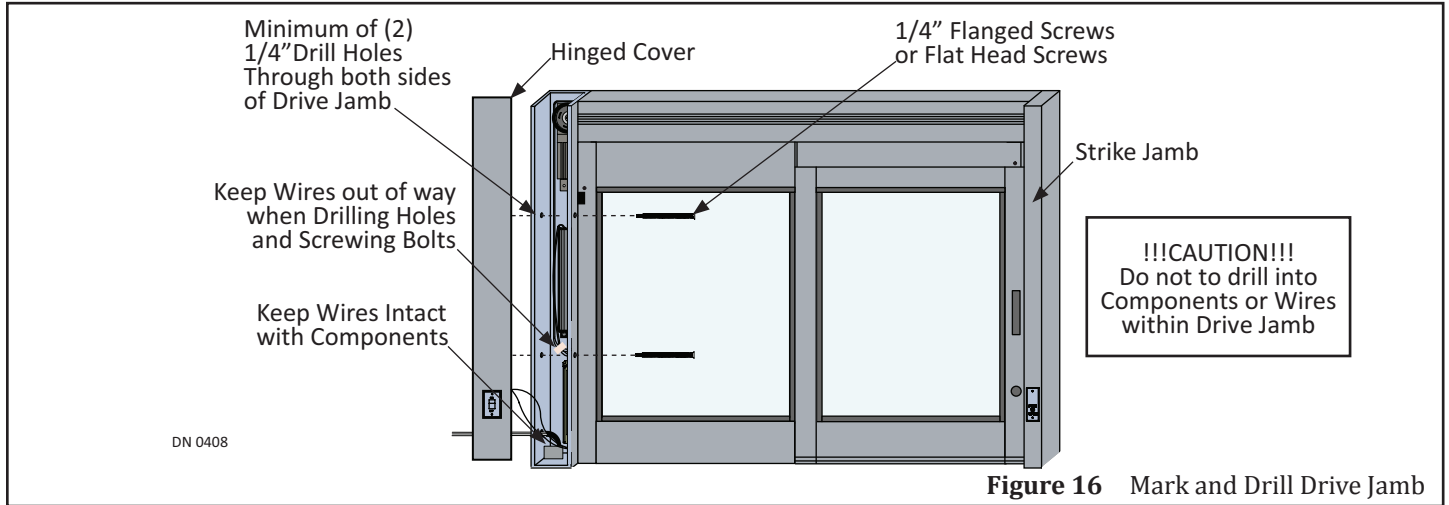

Figure 16 Mark and Drill Drive Jamb

- 4. Secure the Drive Jamb with 1/4 inch diameter fasteners.

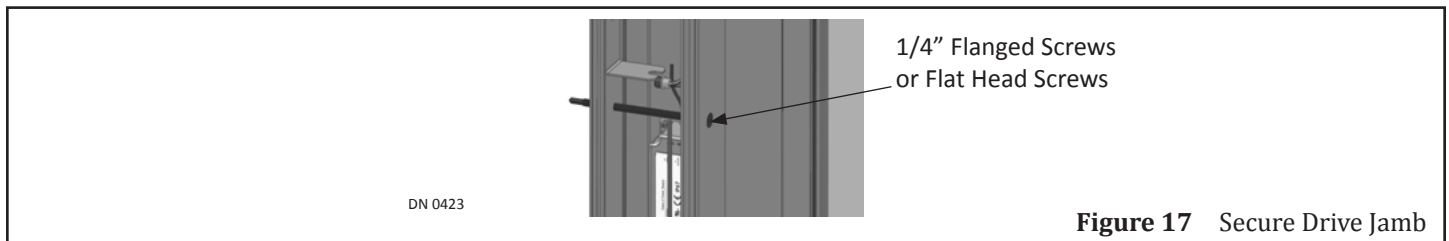

Figure 17 Secure Drive Jamb

- 5. Replace the Hinged Cover.
- 6. Go to the Strike Jamb. Locate the Lock Cutout.
- 7. Mark and drill (1) 1/4 inch diameter hole inside the Lock Cutout.
  - a. Do Not drill into any major components or cut wiring inside.
  - b. When moving wires, ensure to keep wires intact with components.
- 8. Mark and drill a minimum of (1) or more 1/4 inch diameter hole(s) evenly spaced on face of Strike Jamb.

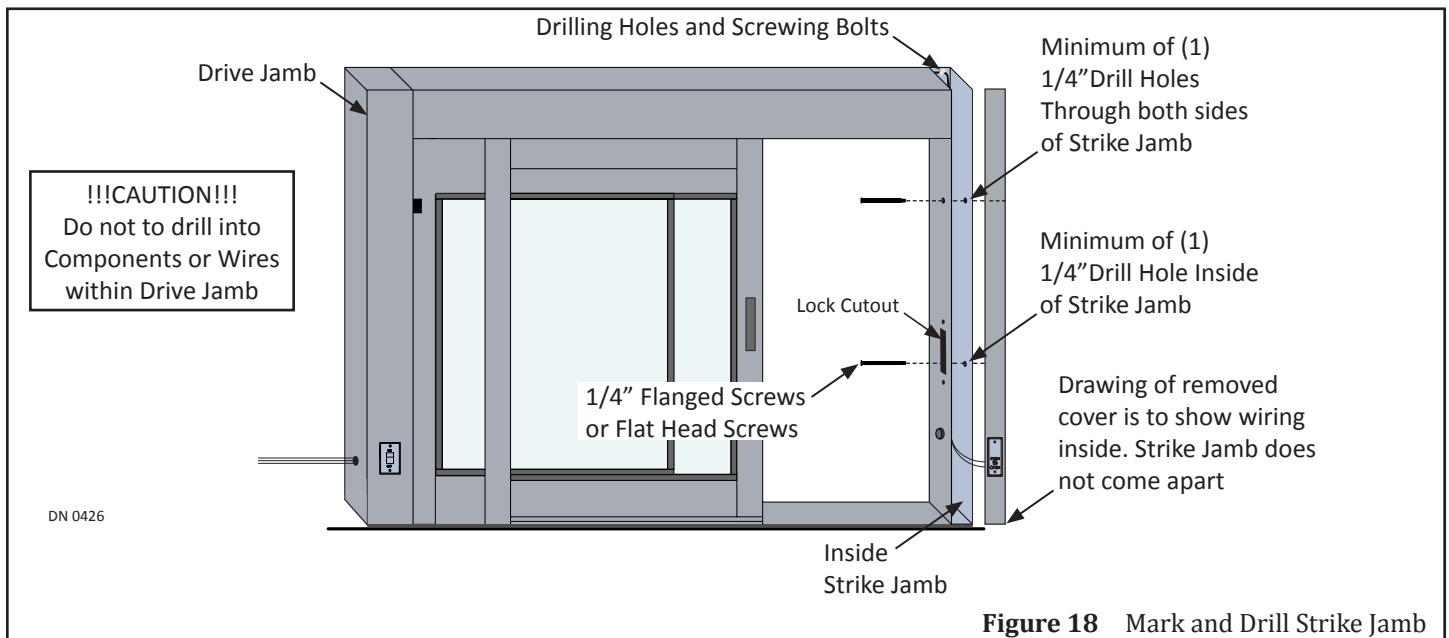
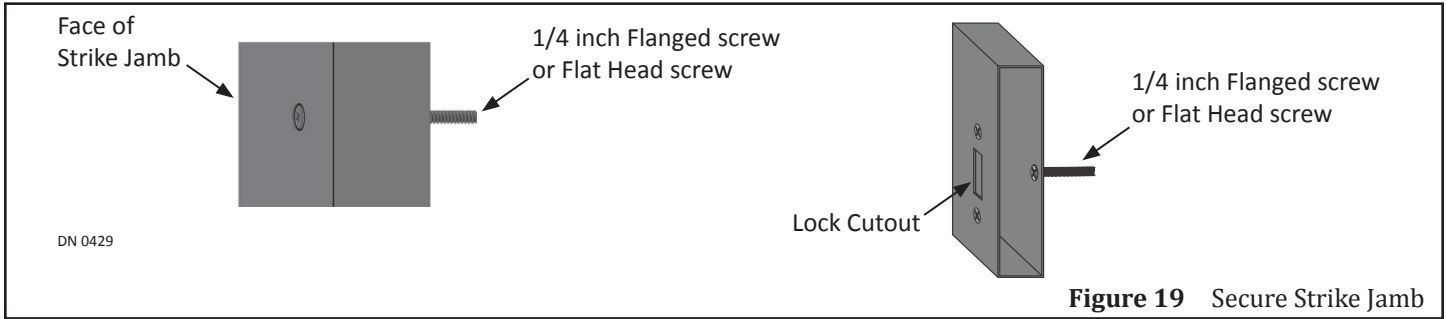
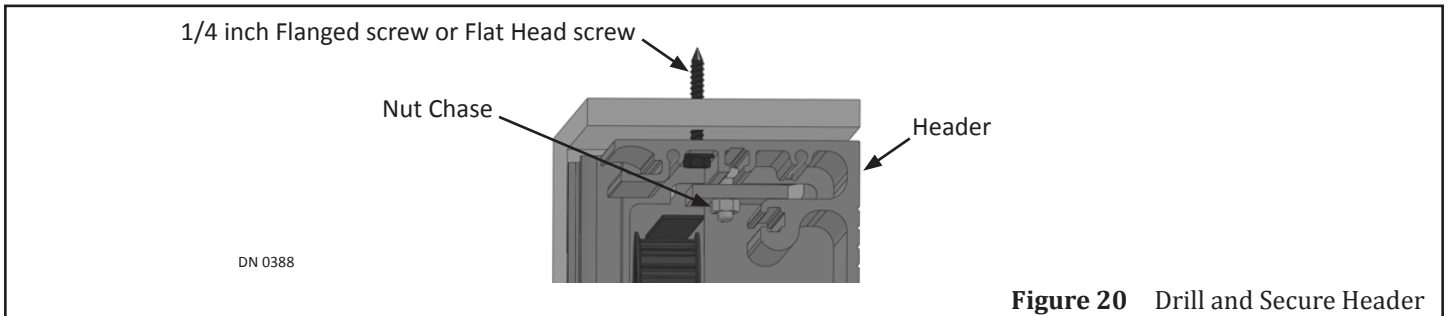

Figure 18 Mark and Drill Strike Jamb

- 9. Secure the Strike Jamb tube to the Opening with 1/4 inch diameter fasteners.



10. Go to the Header. Mark and drill 1/4 inch diameter holes in front of the nut chase located inside the Header.
11. Secure the Header with 1/4 inch fasteners.



12. Go to the Threshold.
13. Remove all (4) Bolts that were used to keep the Threshold Components together.
  - a. If only removing (2) Bolts, it is recommended to remove the (2) middle Bolts, or the (2) end Bolts.

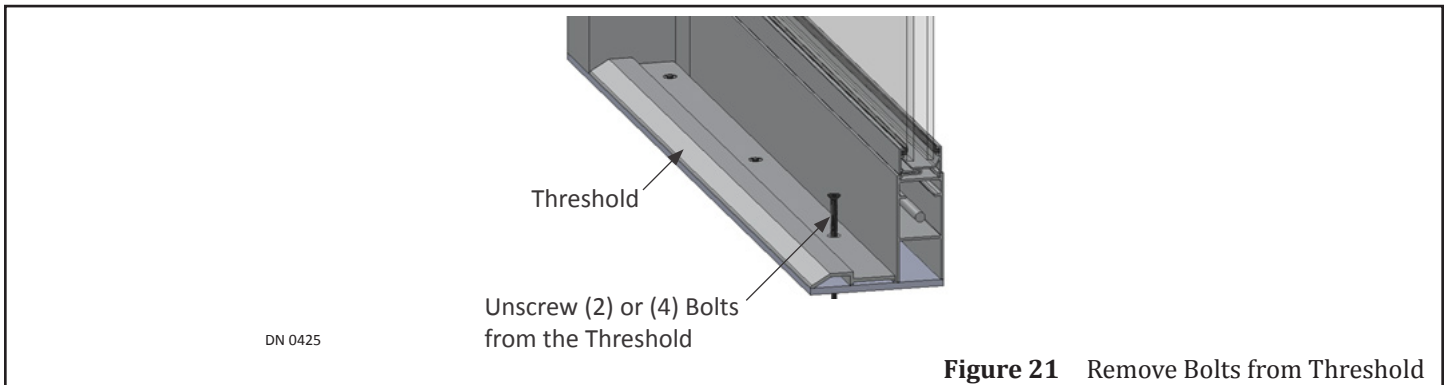

14. Drill 1/4 inch diameter holes through existing screw holes approximately 1-1/2 inch down flat surface.

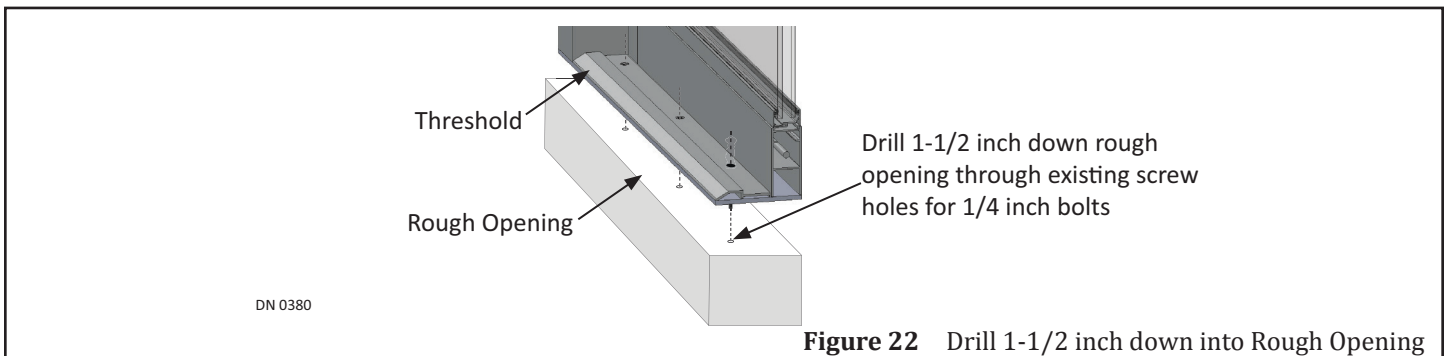

15. Secure Threshold to the opening with (1/4 x 1-1/2 inch) Flange screws or Flat Head screws).

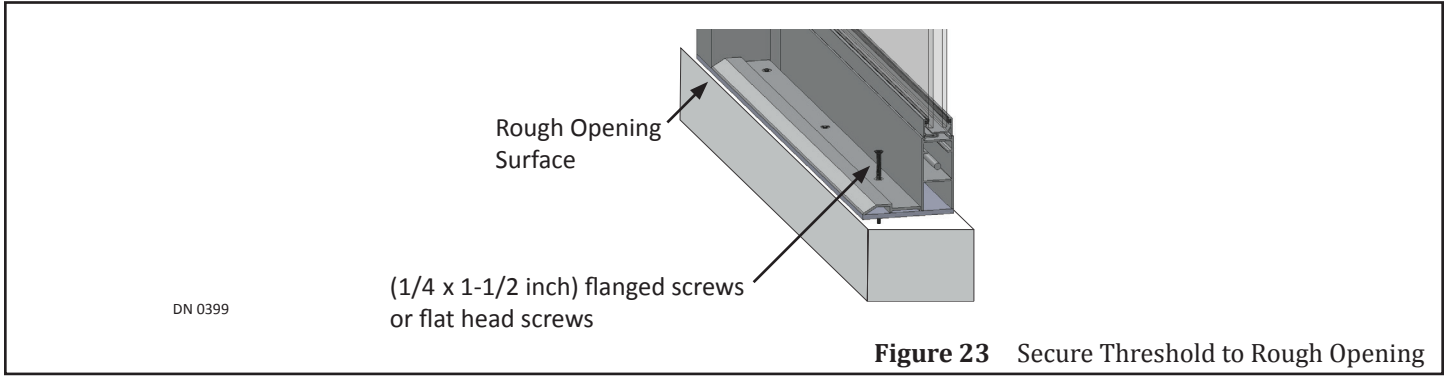

### CHAPTER 9: 120 VAC GENERAL WIRING

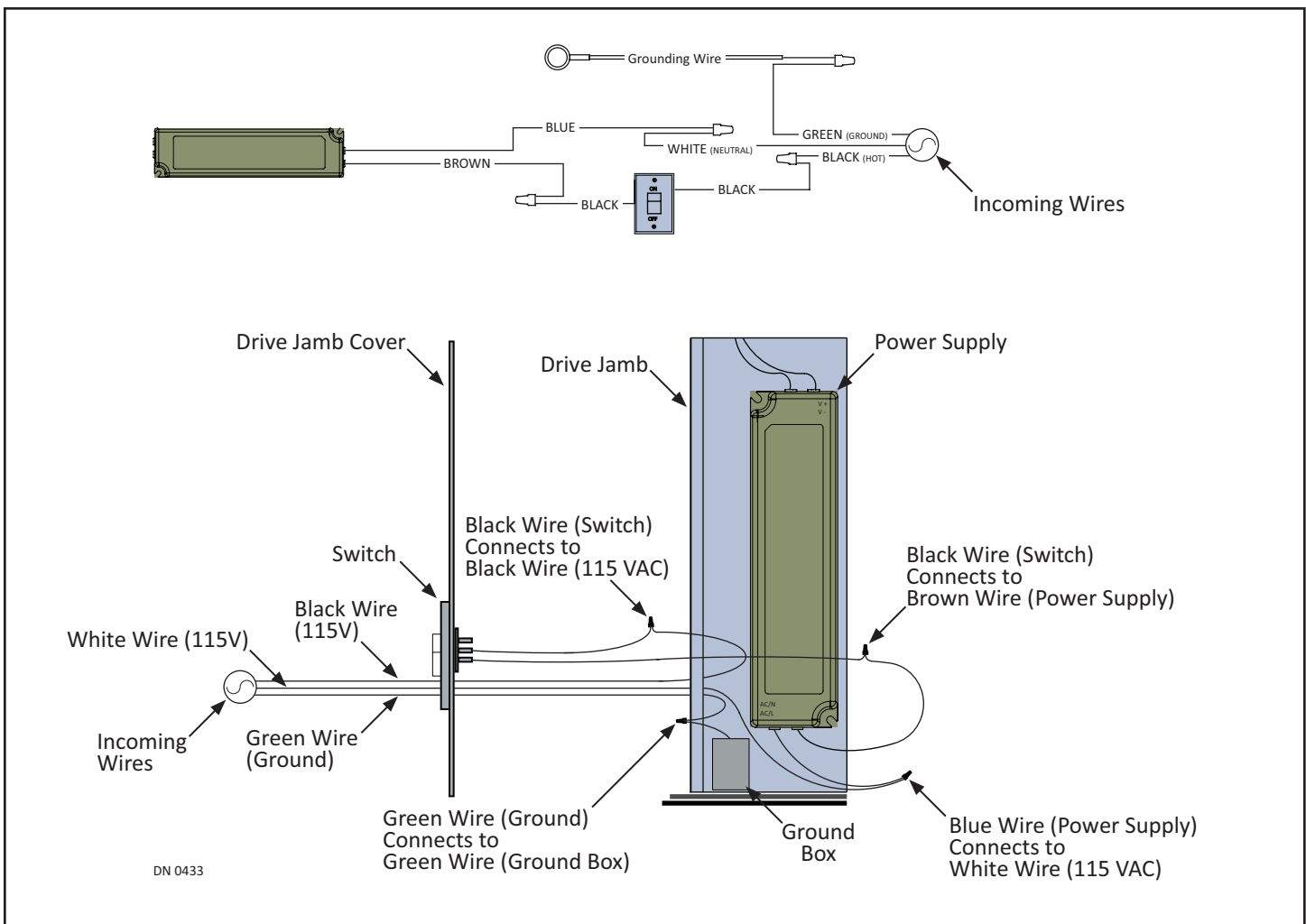



## CHAPTER 11: WEATHERING

1. Ensure the entire Window unit is properly secured to the Rough Opening.
2. Fully insulate the Window inside and outside.

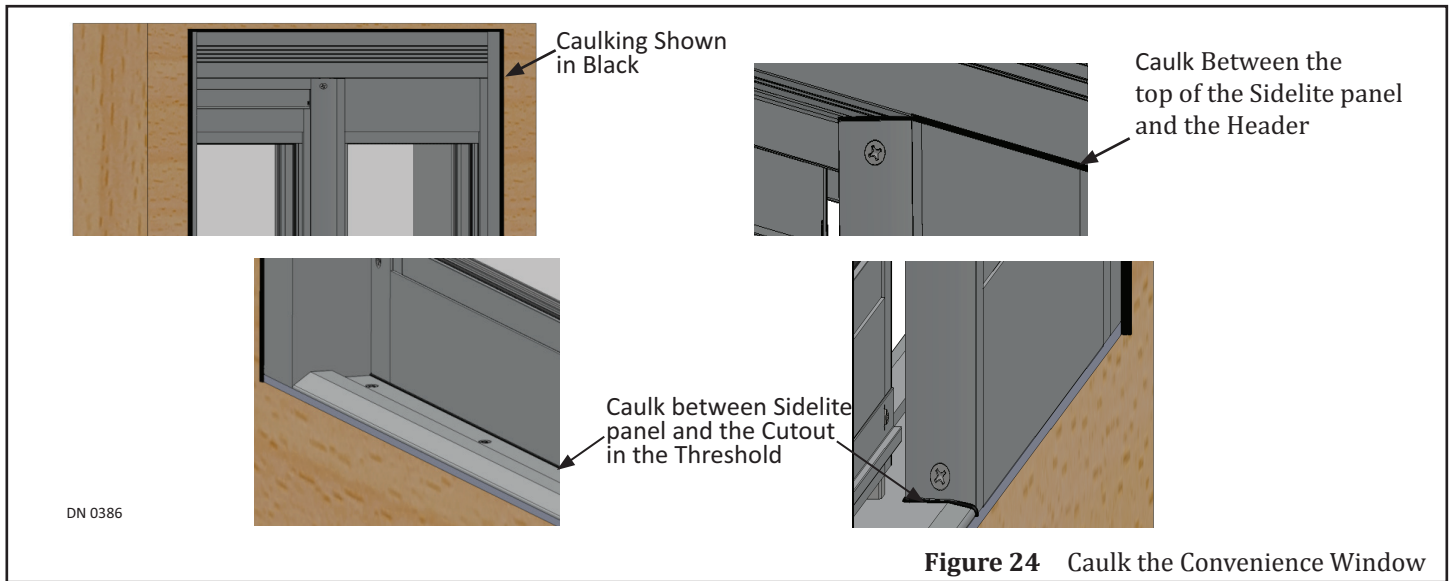

**Figure 24** Caulk the Convenience Window

## CHAPTER 12: COMMON SERVICE PARTS

