



Model GT1175 Telescopic Slide Doors Installation Manual

\*\*with U30 Control\*\*

P/N C-00207 Rev 3-19-18

Nabco Entrances Inc. S82 W18717 Gemini Drive Muskego, Wisconsin 53150
Phone: (877) 622-2694 Fax: (888) 679-3319 www.nabcoentrances.com
NABCO hours of Operation: Monday to Friday 8:00 a.m.- 4:30 p.m. (Central Time)

Associated Manuals Part Numbers: U30 Microprocessor Control Setup and Programming Manual P/N C-00203
Model GT1175 Electrical Installation Manual \*\*with U30 Microprocessor Control P/N C-00198
Automatic Sliding Door Owners Manual (P/N C-00109) for Decal Installation
NABCO Price Book P/N 16-9244-30 (for Sensors, Switches, and Accessories)

WARNING

- Turn OFF all power to the Automatic Door if a Safety System is not working.
• Instruct the Owner to keep all power turned OFF until corrective action can be achieved by a NABCO trained technician. Failure to follow these practices may result in serious consequences.
• NEVER leave a Door operating without all Safety detection systems operational.

Table of Contents

CHAPTER 1: WARNING LABELS 4
CHAPTER 2: GENERAL SAFETY RECOMMENDATIONS 4
CHAPTER 3: SCOPE 5
SECTION 3.1: To the Installer 5
SECTION 3.2: Objective 5
CHAPTER 4: GETTING STARTED 5
SECTION 4.1: Modules 5
SECTION 4.2: Sensors 5
SECTION 4.3: Header Components 6
CHAPTER 5: INSPECT THE ROUGH OPENING 6
CHAPTER 6: ASSEMBLE THE DOOR FRAME (WITHOUT TRANSOM) 7
SECTION 6.1: Full Open Assembly 7
SECTION 6.2: Fixed Sidelite Assembly 8
CHAPTER 7: ASSEMBLE THE DOOR FRAME (WITH TRANSOM) 10
SECTION 7.1: Assemble the Transom to Header 10
SECTION 7.2: Secure the Header to Jamb Tubes 11
CHAPTER 8: SECURE THE DOOR FRAME TO BUILDING 12
SECTION 8.1: Anchor Placements 13
CHAPTER 9: WIRE THE ROCKER SWITCH 13

<b>CHAPTER 10: INSTALL THE THRESHOLD.</b>	<b>14</b>
SECTION 10.1: Install the Surface Threshold.	15
SECTION 10.2: Install the Recessed Threshold	15
<b>CHAPTER 11: INSTALL THE FULL OPEN; SIDELITE.</b>	<b>15</b>
SECTION 11.1: Secure the Bottom Pivot to the Jamb Tube	15
SECTION 11.2: Partially Install the Limit Arm	16
SECTION 11.3: Install the Full Open Sidelite onto the Upper Pivot and Bottom Pivot	16
SECTION 11.4: Complete the Installation of the Limit Arm	17
SECTION 11.5: Adjust the Ball Detents	17
<b>CHAPTER 12: INSTALL THE FULL OPEN; TRAIL DOOR</b>	<b>18</b>
<b>CHAPTER 13: INSTALL THE FULL OPEN; LEAD DOOR</b>	<b>19</b>
<b>CHAPTER 14: INSTALL THE FIXED; SIDELITE</b>	<b>21</b>
<b>CHAPTER 15: INSTALL THE FIXED SIDELITE; TRAIL DOOR.</b>	<b>23</b>
<b>CHAPTER 16: INSTALL THE FIXED SIDELITE; LEAD DOOR</b>	<b>25</b>
<b>CHAPTER 17: PERMANENTLY INSTALL THE THRESHOLD.</b>	<b>27</b>
SECTION 17.1: Threshold Maintenance	27
<b>CHAPTER 18: INSTALL WEATHERING</b>	<b>27</b>
SECTION 18.1: Full Open Units.	27
SECTION 18.2: Fixed Sidelite Units.	28
SECTION 18.3: Caulk the Door Frame to Rough Opening	28
<b>CHAPTER 19: INSTALL THE GLASS STOPS.</b>	<b>28</b>
SECTION 19.1: Transom	28
SECTION 19.2: Header	29
<b>CHAPTER 20: GLAZING (HEAVY/WIDE DOORS).</b>	<b>30</b>
<b>CHAPTER 21: ADJUSTMENTS.</b>	<b>30</b>
SECTION 21.1: Adjust the Hanger Rollers	30
SECTION 21.2: Adjust the Interlocks	31
SECTION 21.3: Adjust the Ball Plunger	31
SECTION 21.4: Adjust Preload	32
SECTION 21.5: Correct Preload Misalignment	32
SECTION 21.6: Adjust the Breakout Magnet.	33
SECTION 21.7: Adjust the Nose Caster	33
SECTION 21.8: Belt Adjustment	34

**SERVICE PARTS: NON HANDED KIT P/N A-00408 . . . . . 36**

**SERVICE PARTS: LH KIT P/N A-00619; RH KIT P/N A-00618 . . . . . 37**

**SERVICE PARTS: HEADER . . . . . 38**

**SERVICE PARTS: LEFT HAND FIXED SIDELITE . . . . . 41**

**SERVICE PARTS: RIGHT HAND FIXED SIDELITE . . . . . 42**

**SERVICE PARTS: LEFT HAND TRAIL DOOR FOR FIXED SIDELITE. . . . . 44**

**SERVICE PARTS: RIGHT HAND TRAIL DOOR FOR FIXED SIDELITE . . . . . 45**

**SERVICE PARTS: LEFT HAND LEAD DOOR FOR FIXED SIDELITE . . . . . 47**

**SERVICE PARTS: RIGHT HAND LEAD DOOR FOR FIXED SIDELITE. . . . . 48**

**SERVICE PARTS: LEFT HAND FULL OPEN SIDELITE. . . . . 51**

**SERVICE PARTS: RIGHT HAND FULL OPEN SIDELITE . . . . . 52**

**SERVICE PARTS: LEFT HAND FULL OPEN TRAIL DOOR . . . . . 55**

**SERVICE PARTS: RIGHT HAND FULL OPEN TRAIL DOOR . . . . . 56**

**SERVICE PARTS: LEFT HAND FULL OPEN LEAD DOOR . . . . . 59**

**SERVICE PARTS: RIGHT HAND FULL OPEN LEAD DOOR . . . . . 60**

**SERVICE PARTS: TRANSOM CLIP, GLASS STOPS, AND VINYL . . . . . 63**

## CHAPTER 1: WARNING LABELS

Warning labels are universal and used to alert an individual of potential harm to one's self or to others. The following warning labels are listed in a hierarchy order that defines the most potential danger first, and the least potential danger last. Please refer to this page in the event that a warning label is displayed within this manual and further definition needs to be explained.

**DANGER**

Indicates potentially dangerous situations. Danger is used when there is a hazardous situation where there is a *high* probability of severe injury or death. It should not be considered for property damage unless personal injury risk is present.

**WARNING**

Indicates a hazardous situation which has *some* probability of severe injury. It should not be considered for property damage unless personal injury risk is present.

**CAUTION**

Indicates a hazardous situation which *may result in a minor injury*. Caution should not be used when there is a possibility of serious injury. Caution should not be considered for property damage accidents unless a personal injury risk is present.

**Attention:** A situation where material could be damaged or the function impaired.

**Notice:** Indicates a statement of company policy as the message relates to the personal safety or protection of property. Notice should not be used when there is a hazardous situation or personal risk.

*Note:* Indicates important information that provides further instruction.

## CHAPTER 2: GENERAL SAFETY RECOMMENDATIONS

**WARNING**

Do not install, operate or service this product unless you have read and understand the General Safety Recommendations, Warning Labels, contained in this manual. Failure to do so may result in bodily injury, or property damage.

**WARNING**

Read, study and understand the installation and operating instructions contained in, or referenced in this manual before operating. If you do not understand the instruction, ask a qualified technician. Failure to do so may result in bodily injury, or property damage and will nullify all warranties.

**DANGER**

Disconnect all power to the junction box prior to making any electrical connections. Failure to do so may result in serious personal or fatal injury. When uncertain whether power supply is disconnected, always verify using a voltmeter.

**DANGER**

Do not place finger or uninsulated tools inside the electrical controller. Touching wires or other parts inside the enclosure may cause electrical shock, serious injury or death.

**CAUTION**

The Ground wire from the Magnum IV Control 120 VAC Harness, and the Incoming 120 VAC Ground wire must be connected to the Ground screw located within the Swing door Header.

**CAUTION**

If the door appears broken or does not seem to work correctly, it should be immediately removed from service until repairs can be carried out or a qualified service technician is contacted for corrective action.

**Notice:** This manual, the owner's manual and all other associated manuals must be given to and retained by the purchasing facility or end user.

**Notice:** Wiring must meet all local, state, federal or other governing agency codes.

**Notice:** All electrical troubleshooting or service must be performed by qualified electrical technicians and must comply with all applicable governing agency codes.

## CHAPTER 3: SCOPE

### SECTION 3.1: To the Installer

The purpose of this manual is to familiarize the installer and purchaser with the proper installation and operation of this system. It is essential that this equipment be properly installed and operational before the door is used by the public. It is the installer's responsibility to inspect the operation of the entrance system to be sure it complies with any applicable standards. In the United States, ANSI Standard 156.10 covers the GT-1175 Slide Door System. Other local standards or codes may apply. Use them in addition to the ANSI standard. The GT-1175 is listed with the Underwriters Laboratory and is identified as such on the label.

Instruct the building owners and operator on the essentials of the operation of the door and this device. The owner should follow these instructions to determine whether the door is operating properly and should immediately call for service if there is any malfunction. All installation changes and adjustments must be made by qualified, NABCO trained technicians.

### SECTION 3.2: Objective

The GT-1175 Standard Slide Door system is designed to be installed within a Rough Opening of a Building. The door function is controlled by the U30 Microprocessor Control. This control offers many features to accommodate most installation options. This manual offers step by step instructions.

#### CAUTION

**A pedestrian Door that does not have its glass sections installed at the Factory shall specify that the glazing material employed is to comply with the requirement in UL 325 par.29.5.1:**

**“The glazing material in both fixed and sliding panels of all sliding doors and in all unframed swinging doors shall comply with the requirements in the Performance Specifications and Methods of Test for Safety Glazing Material Used in Buildings, ANSI Z97.1. Glazing material for other pedestrian doors shall also comply with ANSI Z97.1, except that single strength or heavier glass may be used for those portions of doors involving a glazed area of less than 1ft<sup>2</sup> (0.9 m<sup>2</sup>) and having no dimension greater than 18 in (457 mm)”.**

## CHAPTER 4: GETTING STARTED

The U30 Microprocessor Control is utilized on all GT-1175 Slide Door systems to control numerous operating characteristics that include (but not limited to): speed, recycling sensitivity and reduced opening width.

The U30 Microprocessor Control is also utilized to output power to accessories and auxiliary equipment. However, there are times when the U30 Microprocessor Control is not utilized to output power because some accessories or auxiliary equipment are shipped with it's own dedicated power supply.

### SECTION 4.1: Modules

Module	Part Number	Function	Power Source	Current Consumption
Optex Beam	A-00709	Beam & Control	12 to 24 AC or DC	160mA
CP/RX Radio Control Receiver	24-11467	RF Signal Transmission	12 to 24 AC or DC	50mA

(ea.unit) at 12VDC

### SECTION 4.2: Sensors

Sensor	Part Number	Function	Power Source	Current Consumption
Acusensor M	V-00741	Infrared	12-24 Volts AC or DC	150mA
BEO IXIO	V-00057	Infrared + Microwave	12 to 24 VAC 12 to 35 VDC +/-10%	100mA
Optex I-ONEX T	V-00746	Infrared	12 to 24 VAC or 12 to 30 VDC	130mA
Acuzone T	V-00745	Infrared + Microwave	12 to 24 VAC +/-10% (50/60 Hz) 12 to 30 VDC +/-10%	6mA

(ea.unit) at 12VDC  
30VDC

**SECTION 4.3: Header Components**

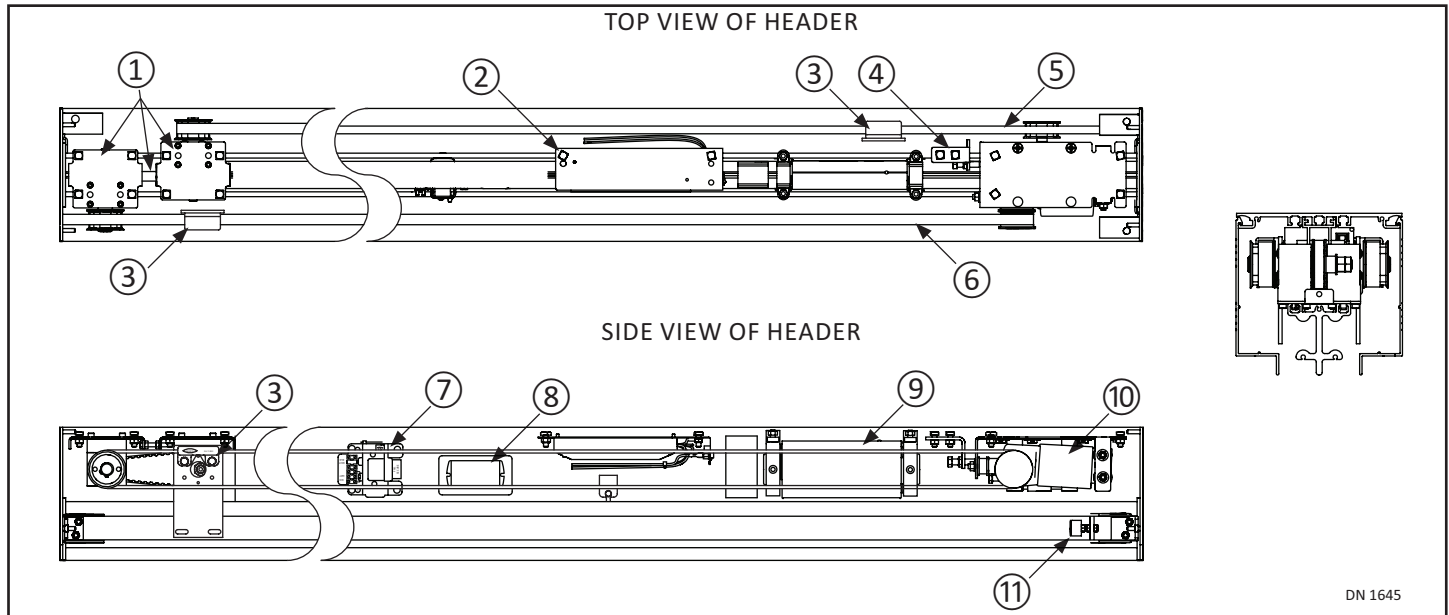

1	2:1 Speed Reducer Assembly	7	Electric Strike Assembly
2	Power Supply	8	Optex Control Box
3	Belt Clip Assembly	9	U30 Microprocessor Control
4	Belt Tension Bracket Assembly	10	Motor Operator Assembly
5	Trail Door Drive Belt	11	Door Stop Assembly
6	Lead Door Drive Belt		

**CHAPTER 5: INSPECT THE ROUGH OPENING**

*Note: Make allowances for tile or other existing materials that may change the floor height.*

1. Ensure the Rough Opening is the correct size.
  - ▶ The width of the Rough Opening should equal: Package Width + 1/4 inch on each side
  - ▶ The height of the Rough Opening should equal: Package height + 1/4 inch

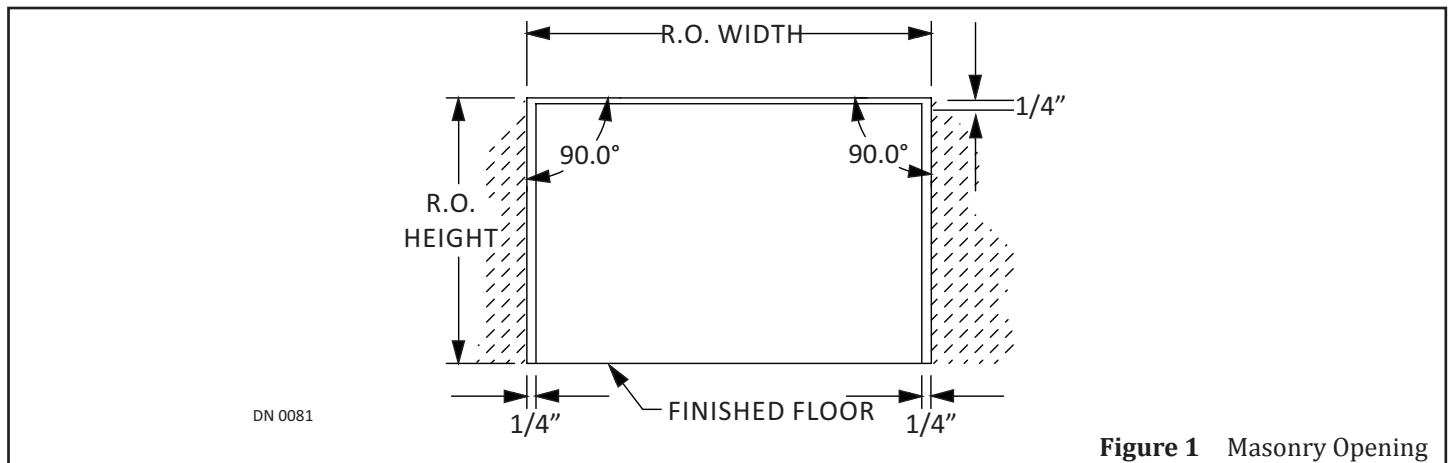

**Figure 1** Masonry Opening

*Note: Make allowances for tile or other existing materials that may change the floor height.*

2. Ensure the floor is level across the entire opening.
  - a. If used, check recessed threshold across the door opening.

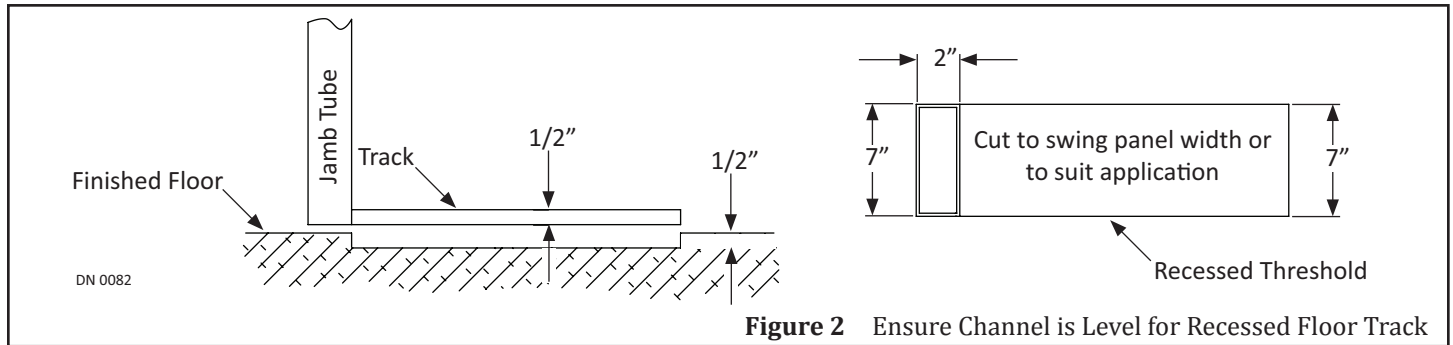

## CHAPTER 6: ASSEMBLE THE DOOR FRAME (WITHOUT TRANSOM)

*FOR DOOR FRAMES WITH A TRANSOM SKIP TO CHAPTER 7*

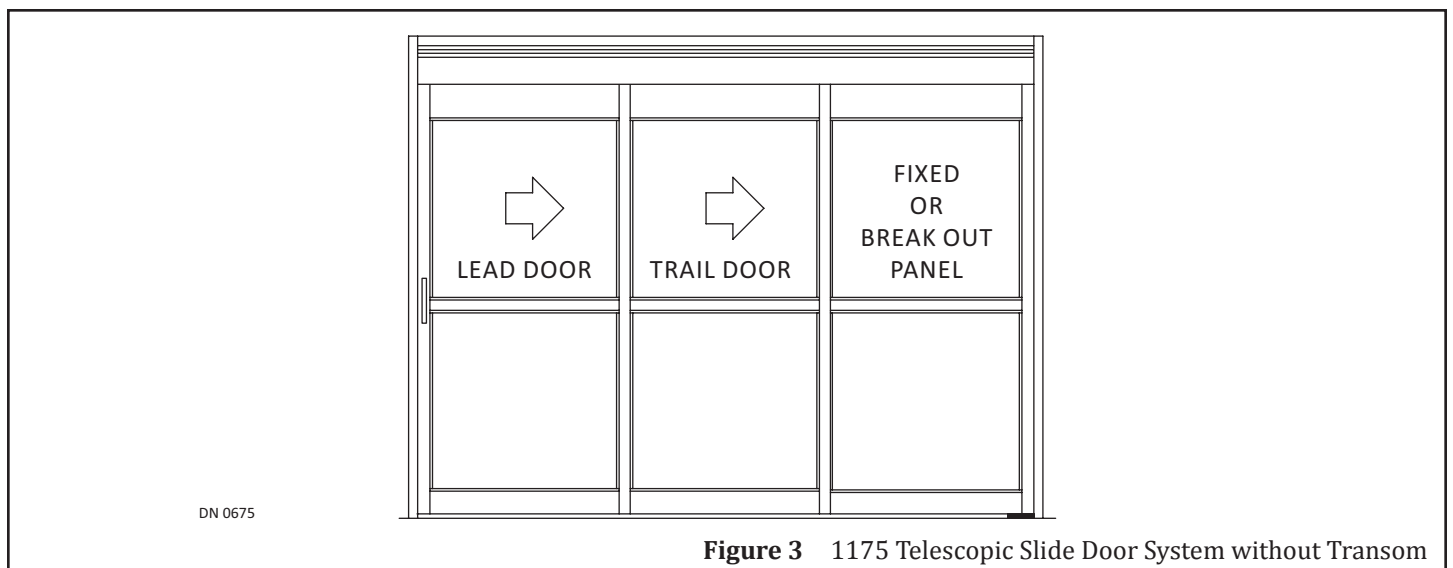

### SECTION 6.1: Full Open Assembly

*FOR FIXED SIDELITE ASSEMBLY SKIP TO SECTION 6.2*

1. The Telescopic Slide door system has (2) removable covers, one on each side of the Header. Place the Header on a flat surface with the notched cover on the top. Protect Header from scratches.
  - a. Notch in Cover allows door clearance when Sidelite is broken out.

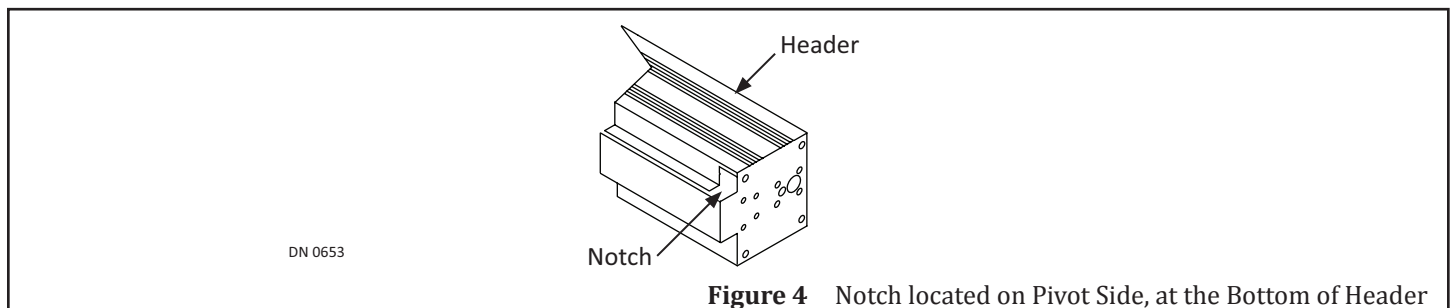

2. Locate (1) Notch at the bottom of the Pivot Jamb Tube (used for the Bottom Pivot).
3. Lay the Pivot Jamb Tube on the floor, so the Notch will be inside the Door Frame and "up" from the floor.
4. Ensure the Pivot Jamb Tube is positioned on the same side of the Header Cover with the Notch.
5. Lay the Strike Jamb Tube on the floor so the predrilled screw holes are properly aligned with the Pivot Jamb Tube.

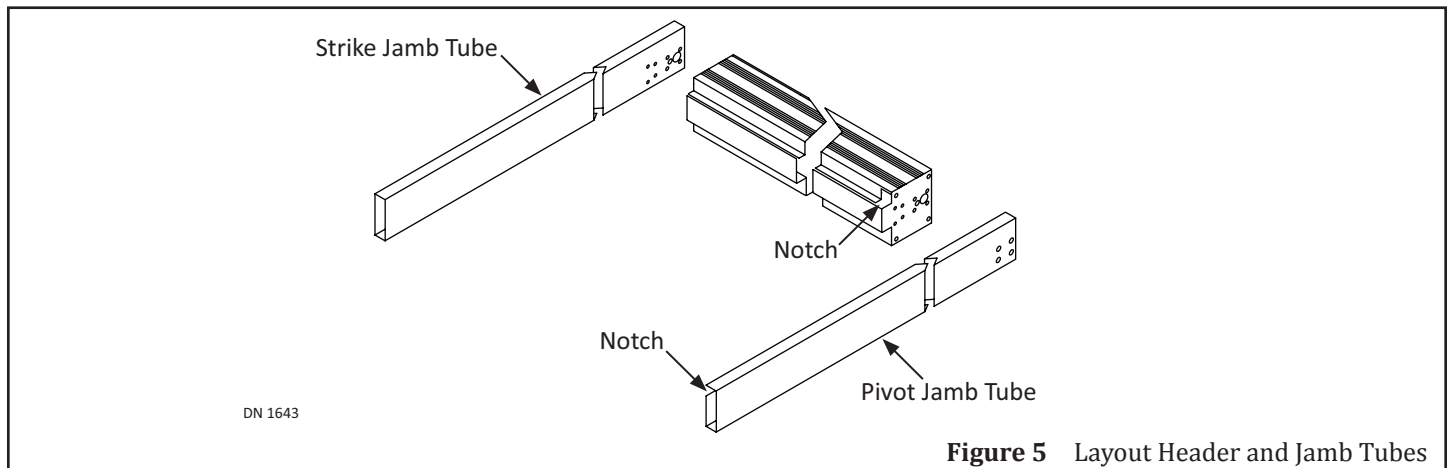

**Figure 5** Layout Header and Jamb Tubes

6. Orientate the Frame so the bottom of Header is facing towards the **Exterior** side of the Door Opening.

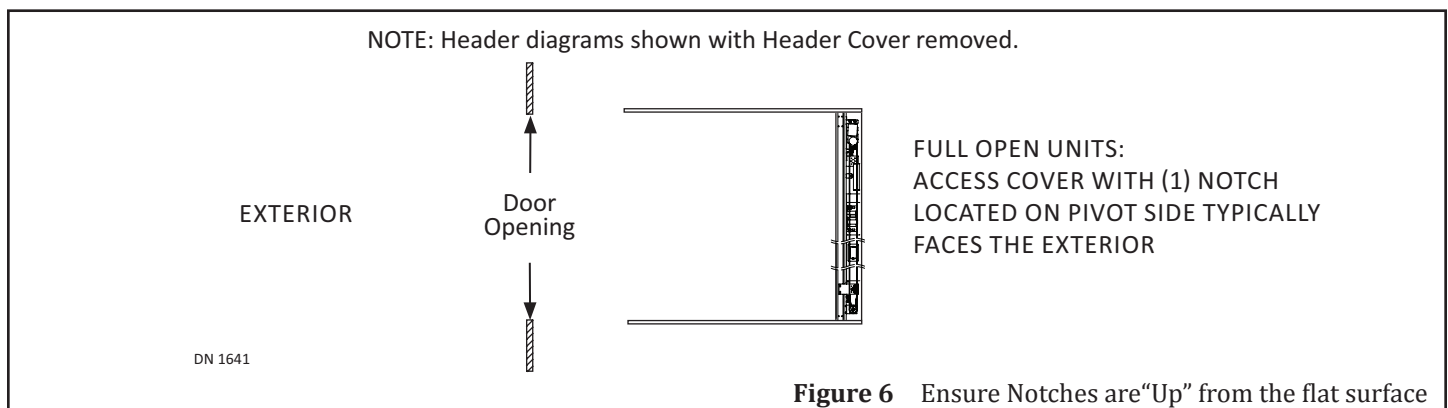

**Figure 6** Ensure Notches are "Up" from the flat surface

## SECTION 6.2: Fixed Sidelite Assembly

1. The Telescopic Slide door system has (2) removable covers, one on each side of the Header. Place the Header on a flat surface with the slotted cover on the top. Protect Header from scratches.
  - a. Without the slot, the Header Cover would be permanently installed behind the Fixed Sidelite Panel.

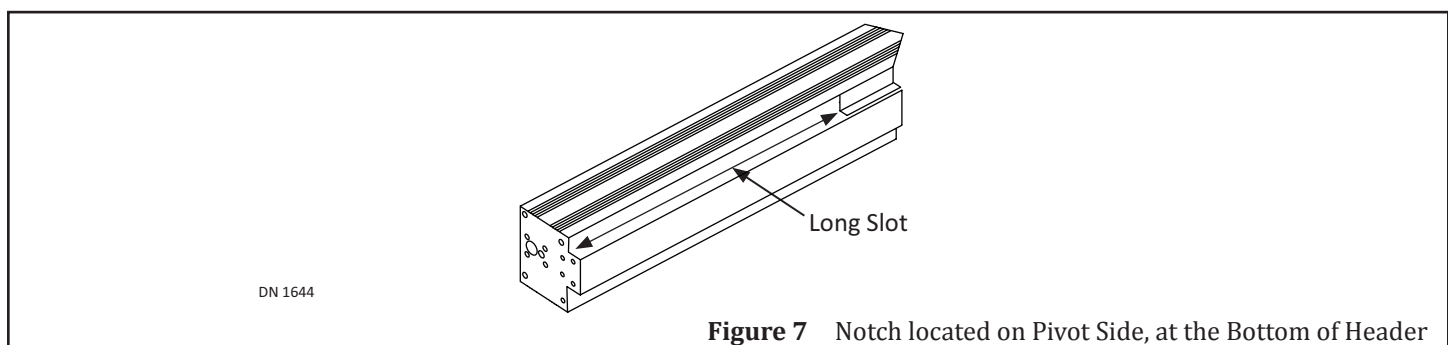

**Figure 7** Notch located on Pivot Side, at the Bottom of Header

2. Locate (1) Notch at the bottom of the Pivot Jamb Tube (used to house Guide Rollers so the Slide Door can fully Open).
  - a. (4) 1/4-20 x 1/2" predrilled screw holes can also be located on the same side of Pivot Jamb Tube.
3. Lay the Pivot Jamb Tube on the floor, so the Notch will be inside the Door Frame and "up" from the floor.
4. Ensure the Pivot Jamb Tube is positioned on the same side of the Header Cover with the Notch.
5. Lay the Strike Jamb Tube on the floor so the predrilled screw holes are properly aligned with the Pivot Jamb Tube.



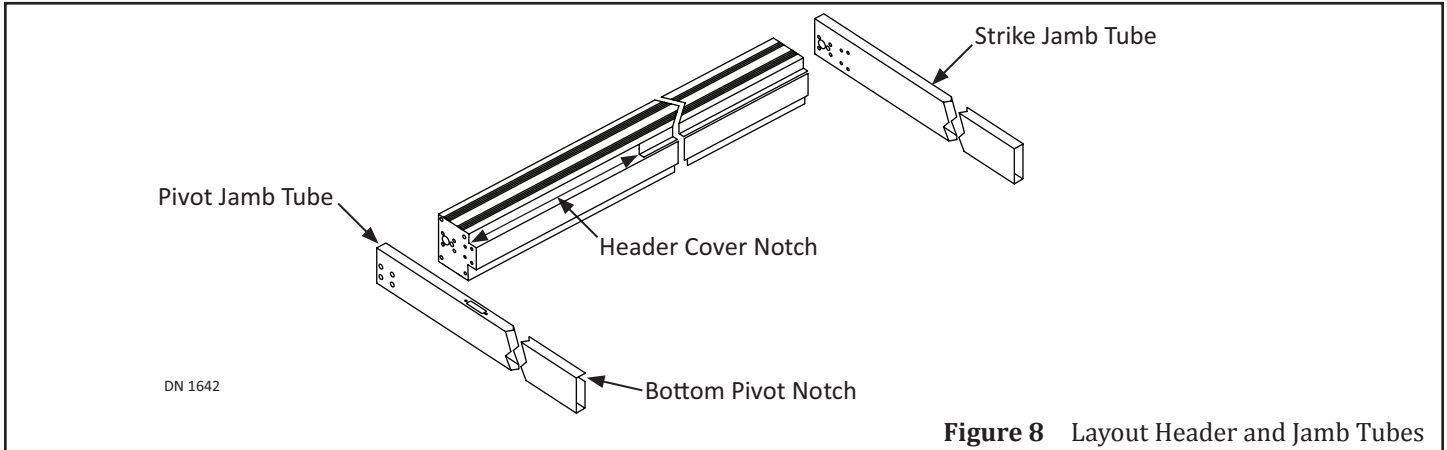

6. Orientate the Frame so the bottom of Header is facing towards the Interior side of the Door Opening.

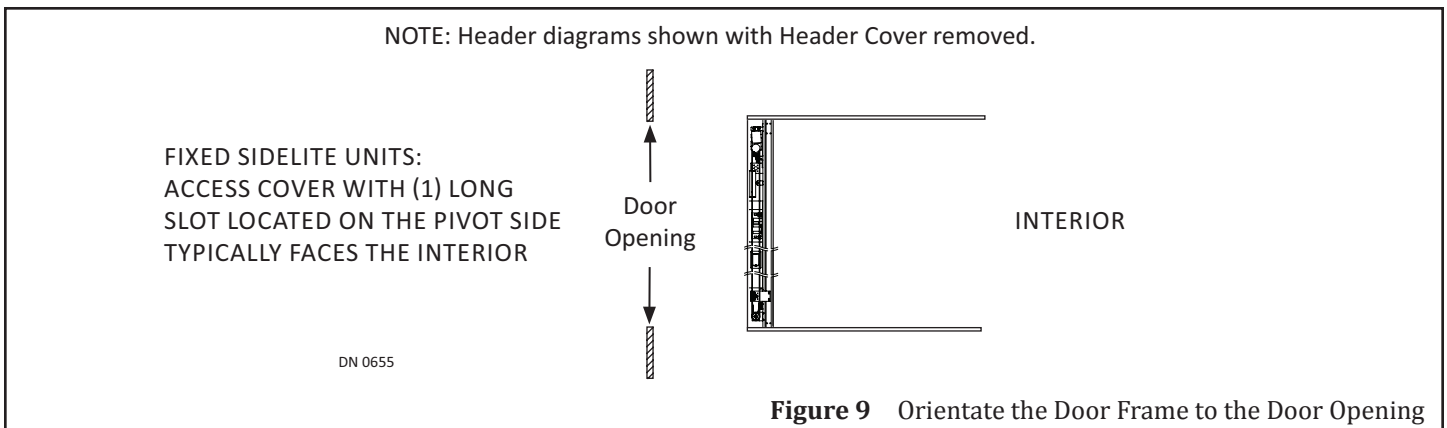

7. Secure the Header to each Jamb Tube with (8) 1/4-20 x 1 inch Whizlock screws provided by NABCO.
  - a. (4) Screws on the inside, (4) Screws on the outside.
  - b. If assembled correctly, the Jamb Tubes will approximately be 1-5/8 inches from the floor.

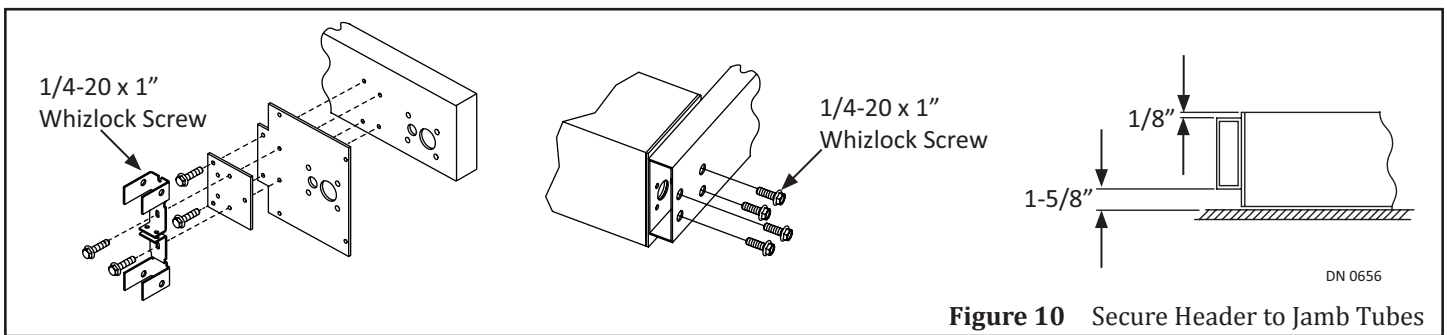

## CHAPTER 7: ASSEMBLE THE DOOR FRAME (WITH TRANSOM)

*Note: For a Frame/Transom assembly that is over 11 feet (132 inches) tall, please call Customer Service at 1-888-679-3319 to special order a reinforced Transom with Tie Rods.*

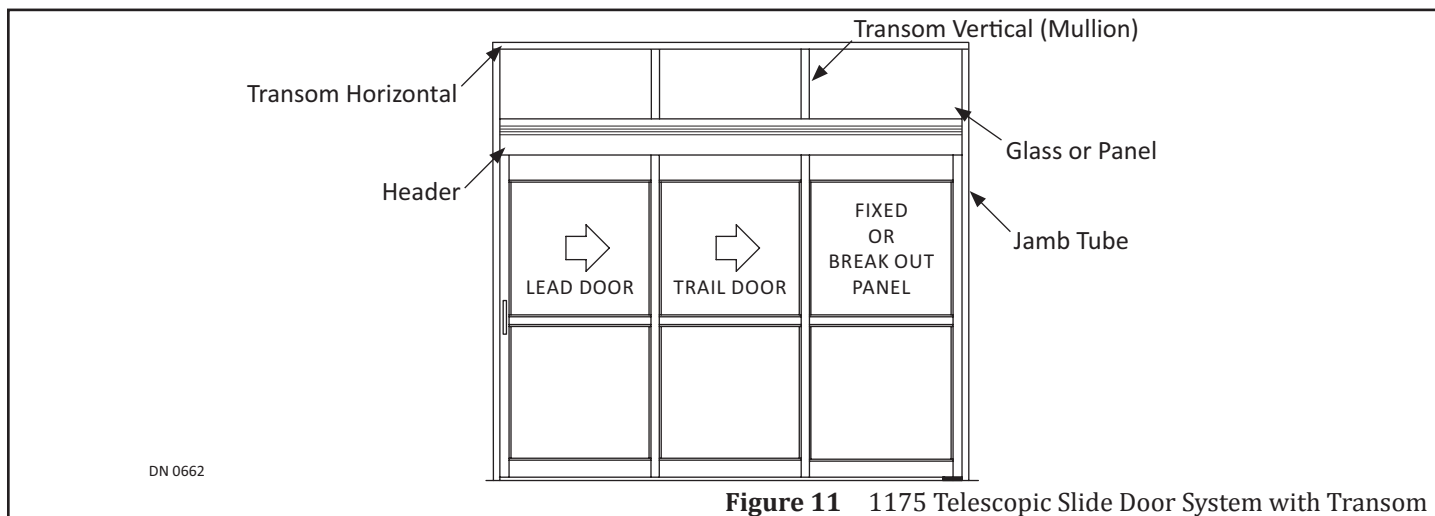

**Figure 11** 1175 Telescopic Slide Door System with Transom

### SECTION 7.1: Assemble the Transom to Header

1. The Telescopic Slide door system has (2) removable covers, one on each side of the Header. Place the Header on a flat surface with the notch or slotted cover on the top. Protect Header from scratches.

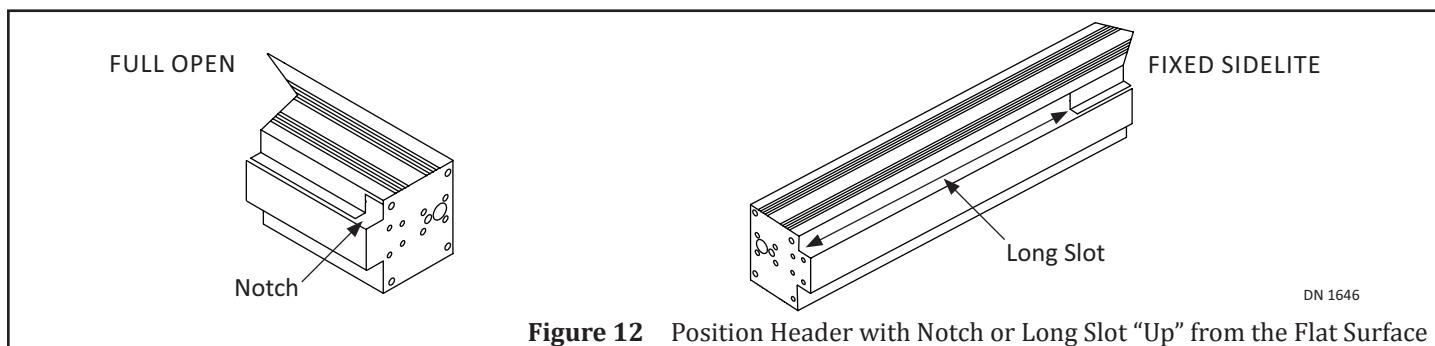

**Figure 12** Position Header with Notch or Long Slot "Up" from the Flat Surface

2. Remove the Header Cover.
3. Locate the pre-drilled 5/8 inch screw holes on the top of Header, and the bottom of the Transom Horizontal.
4. Secure Transom Clips (provided by NABCO) to the Header with #8 x 5/8 inch Self Tapping screws.
  - a. Reserve (4) Transom Clips and (4) #8 x 5/8 inch Self Tapping screws for Jamb Tubes.

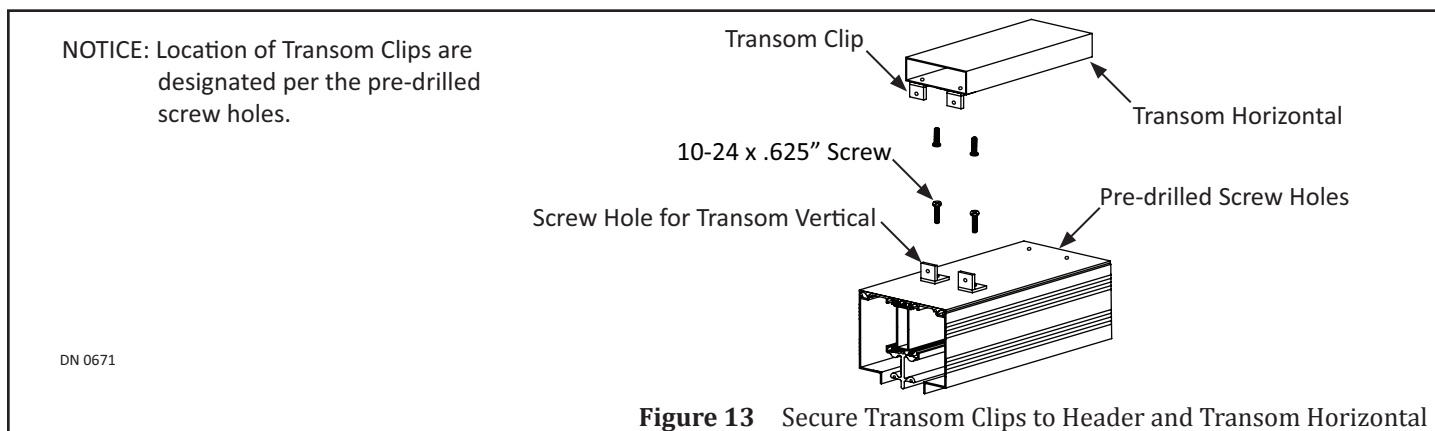

**Figure 13** Secure Transom Clips to Header and Transom Horizontal

5. Secure Transom Clips to each Transom Vertical with 1/4-20 x 1" Flat Head screws.

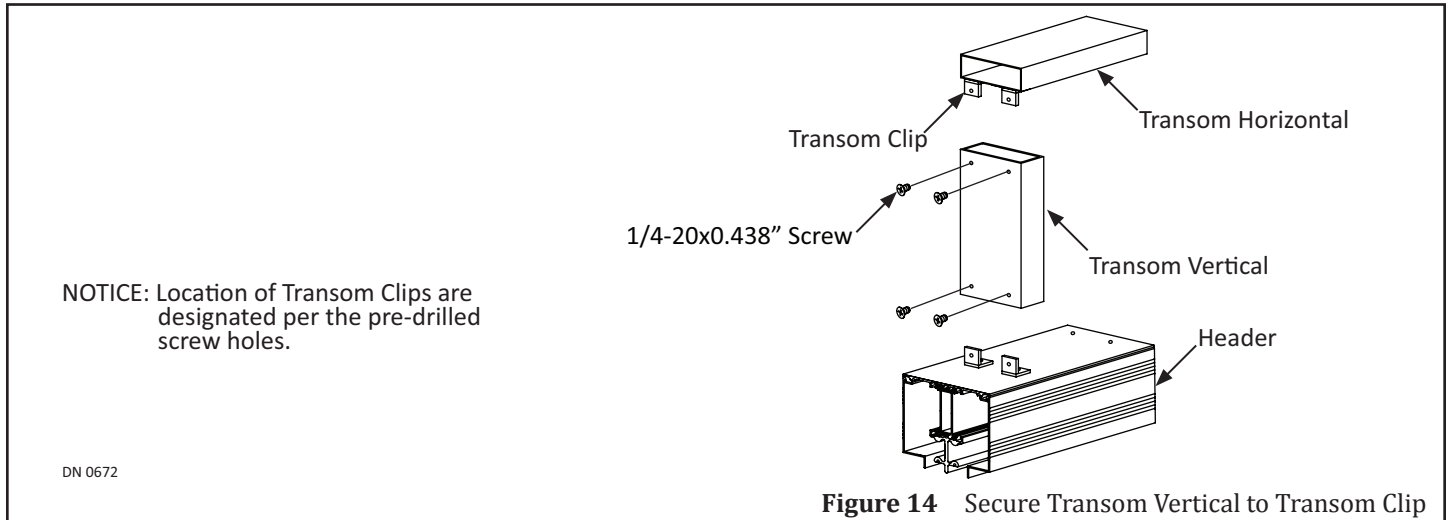

**SECTION 7.2: Secure the Header to Jamb Tubes**

1. Slide (2) Transom Clips located on top of each Jamb Tube, into the Transom Horizontal.
2. Secure each Jamb Tube to either side of the Horizontal Transom with #8 x 1 inch Pan Head screws.

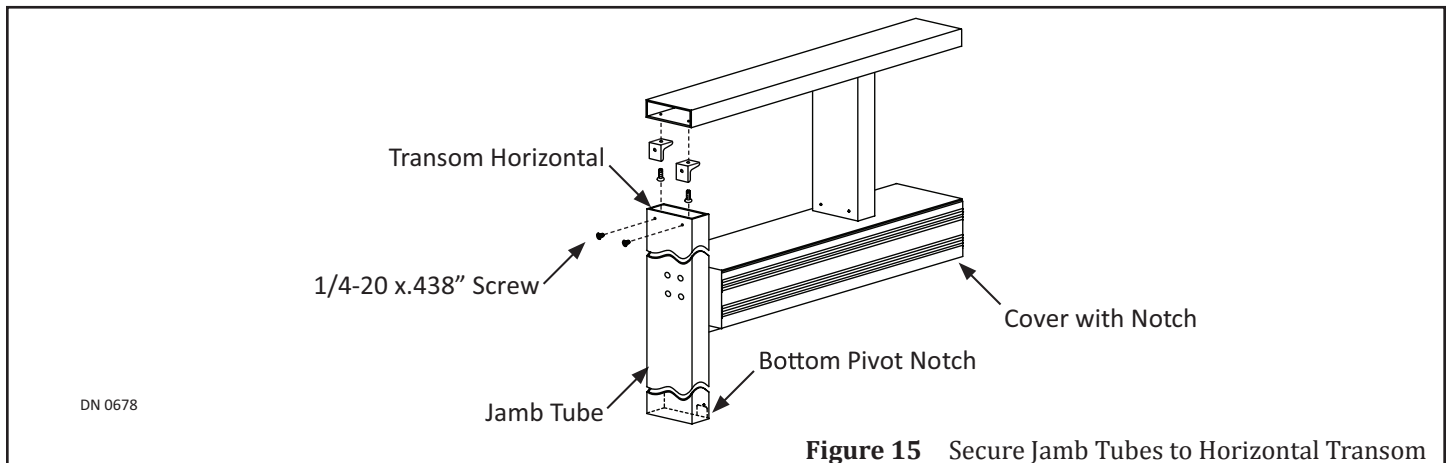

3. Secure the Header to each Jamb tube with (8) 1/4-20 x 1 inch Whizlock Screws by inserting them through the access holes and then into pre-installed rivnuts.
  - a. (4) Screws on the inside, (4) Screws on the outside.

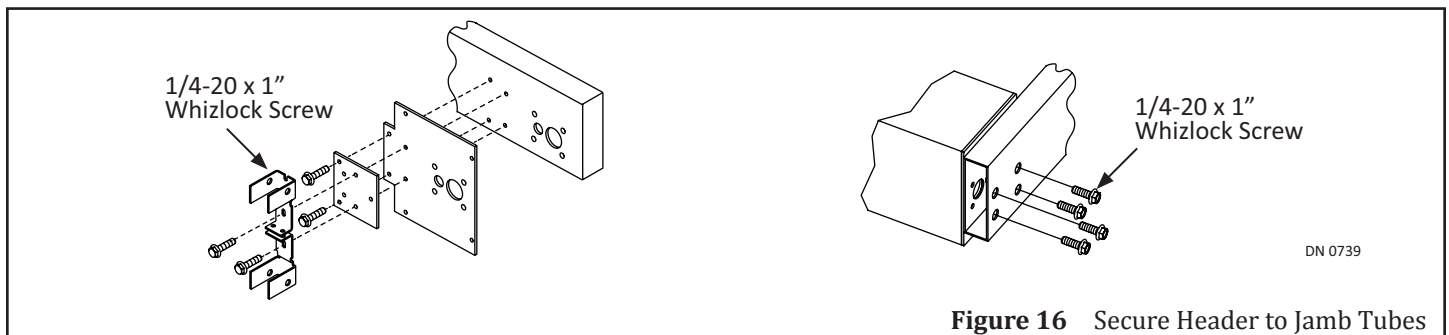

4. Lay the Pivot Jamb on the floor, so the Notch will be inside the Door Frame and "up" from the floor.
  - a. Ensure the Pivot Jamb Tube is positioned on the same side of the Header Cover with the Notch or Long Slot.
5. Lay the Strike Jamb Tube on the floor so the predrilled screw holes are properly aligned with the Pivot Jamb Tube.
  - a. If assembled correctly, the Jamb tubes will approximately be 1-5/8 inches from the floor.

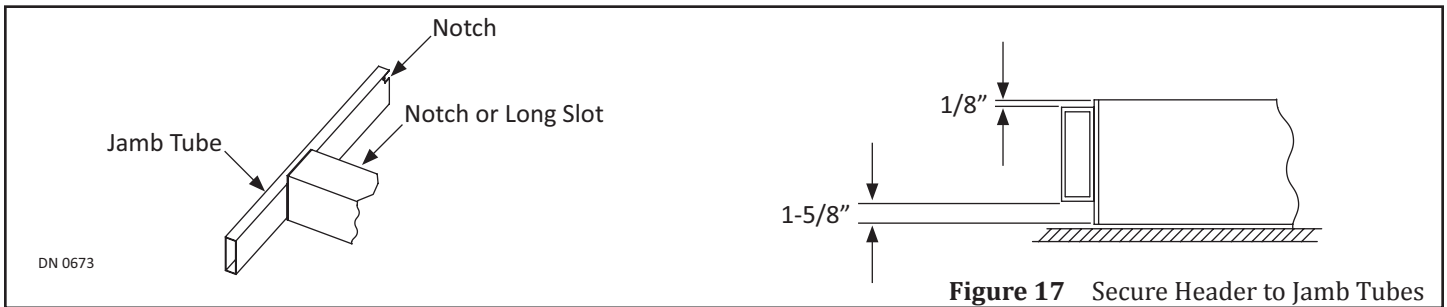

6. Orientate the Frame so the bottom of Header is facing towards the Interior side of the Door Opening.

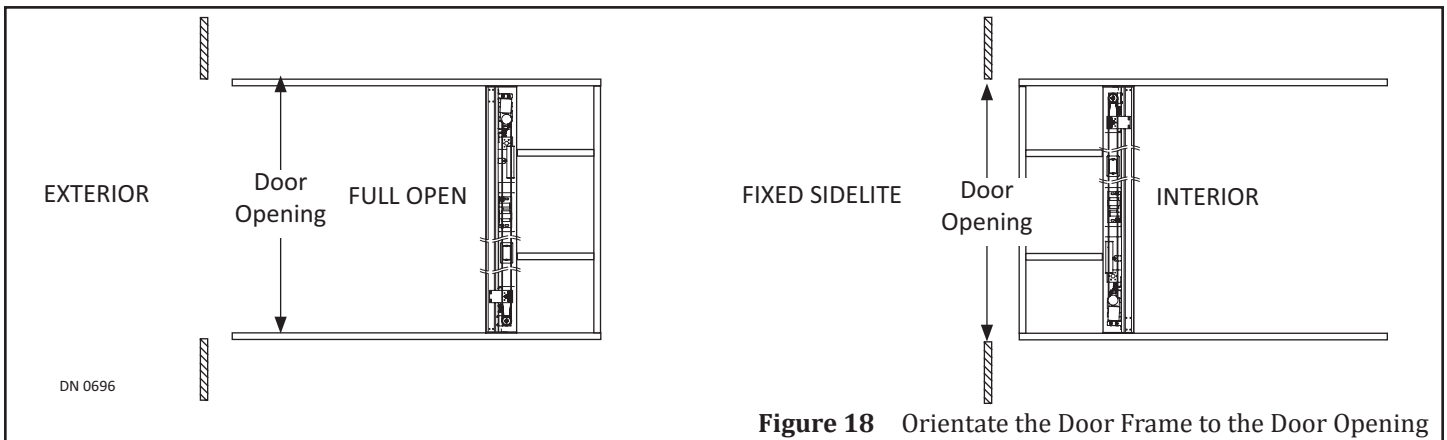

## CHAPTER 8: SECURE THE DOOR FRAME TO BUILDING

1. Protect Header from scratches. Remove screws that are used to secure the Cover to the Header located underneath.
2. Remove the Cover by lifting it up from Header, and then pulling it out.
3. Remove Parts box and/or Parts bags from inside Header. Set aside.

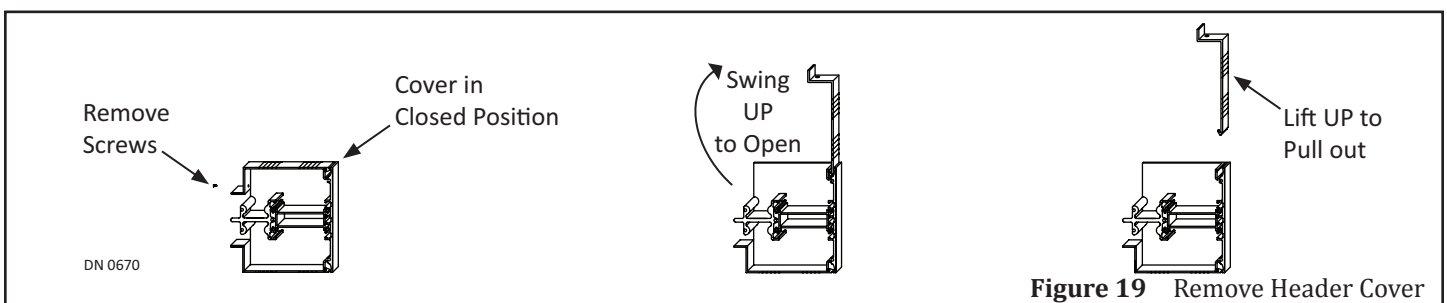

*Note: To prevent electrical interference, always route 120 VAC Power through the Header Endcap, that is located opposite the Controller and Motor/Operator.*

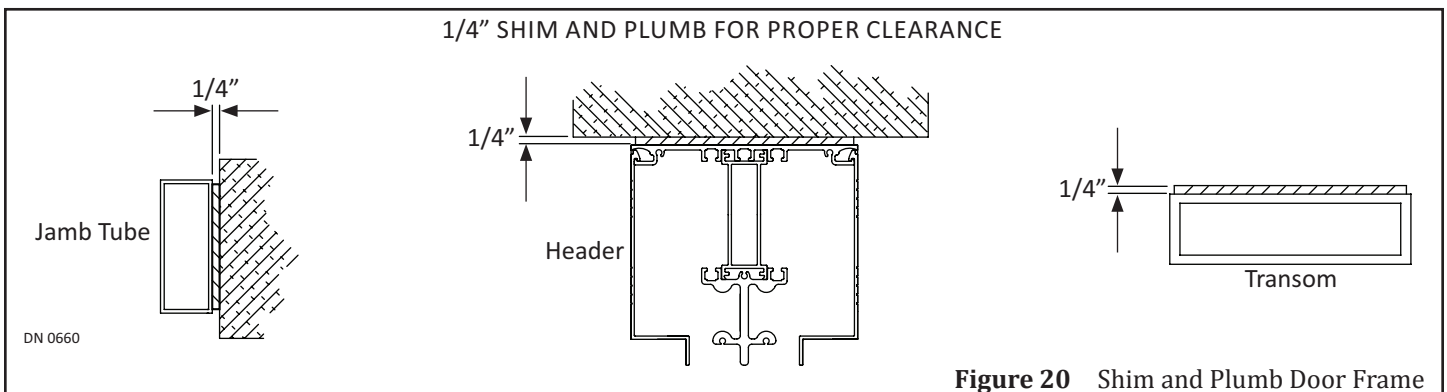

1. Lift to position the assembled Frame into the rough opening.
2. Shim and Plumb Jamb Tubes in both planes to ensure the rough opening allows a 1/4 inch clearance.
3. Shim and plumb the Header or the Transom Horizontal at the top to ensure the rough opening allows a 1/4 inch clearance.

### SECTION 8.1: Anchor Placements

- ▶ Anchors are not provided by NABCO.
- ▶ Anchors must be appropriate for the type of structure being fastened to.
- ▶ Do not overtighten anchors to prevent deforming Jamb tubes.
- ▶ Ensure each visible anchor is flush to the Jamb tube.
- ▶ Ensure anchor heads do not come in contact with edges of glass to prevent breakage.

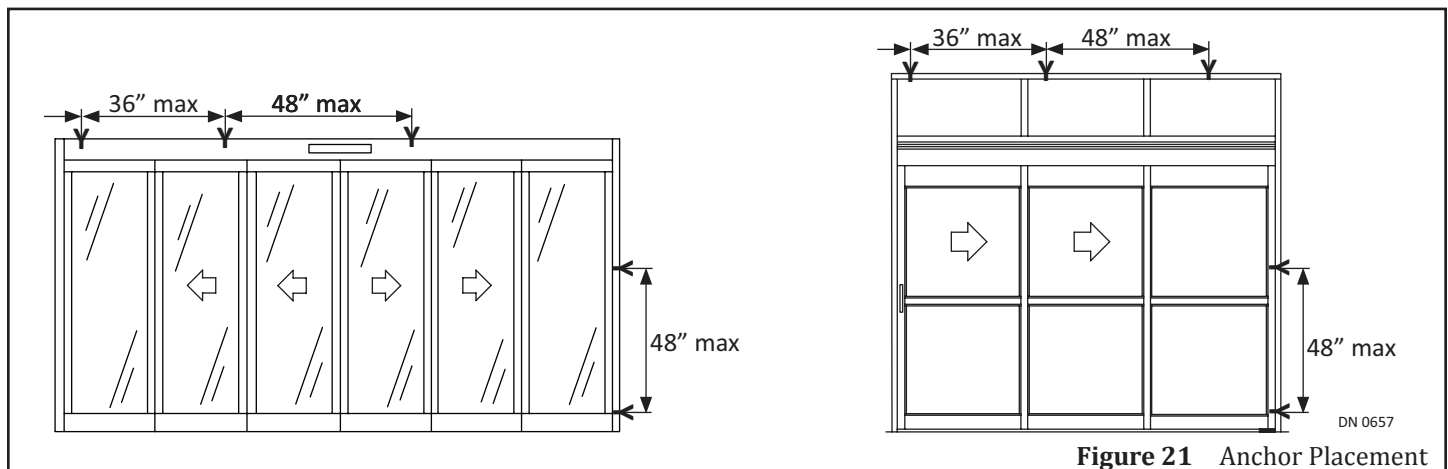

**Figure 21** Anchor Placement

#### 8.1.1 Jamb Tubes

Use 1/4 inch diameter anchors with a minimum of 3 per Jamb tube, maximum is 48 inches on center. Drill 1/4 inch diameter holes in the face of Jamb and then countersink each hole.

#### 8.1.2 Header

To prevent Header sag, use 1/4 inch diameter anchors or 3/8 inch threaded rods, with a maximum 48 inches on center. First anchor maximum is 36 inches from each end of the Header. Drill 1/4 inch diameter holes inside the top of Header.

#### 8.1.3 Transom

Use 1/4 inch diameter anchors with a minimum of 3 per Transom tube, maximum is 48 inches on center. Anchoring is required within 8 inches of all vertical mullions. Drill 1/4 inch diameter holes in the face of Jamb and then countersink each hole.

## CHAPTER 9: WIRE THE ROCKER SWITCH

1. Remove the Rocker Switch and (2) screws from the Jamb Tube.

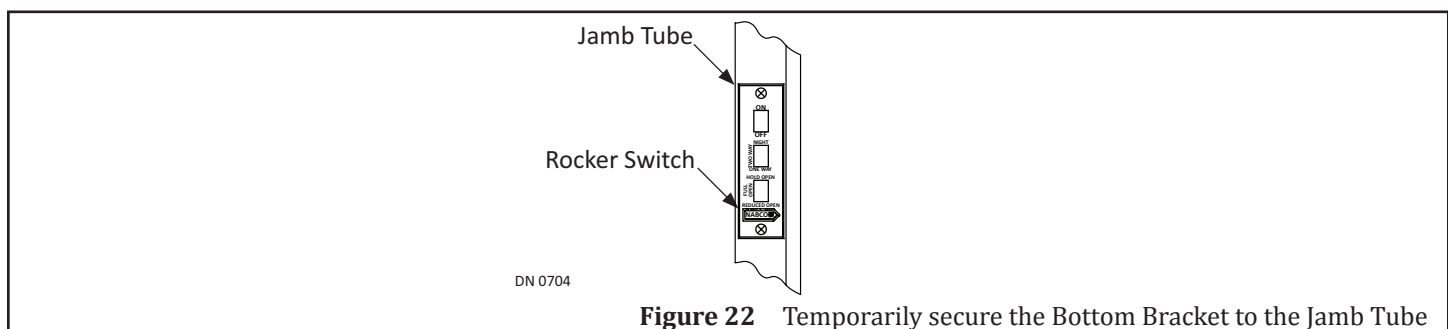

**Figure 22** Temporarily secure the Bottom Bracket to the Jamb Tube

2. There is approximately (2) feet of Cable Wiring connected to the Main Harness inside the Header. Withdraw the Cable Wiring through a hole at the bottom Lip of Header. Continue to route the Cable Wiring through the top of Jamb Tube, then down to where the Rocker Switch was removed.

3. Pull the Cable Wiring through the cut out. Connect the Cable Wiring to the Rocker Switch Harness.
4. Secure the Rocker Switch to the Jamb Tube with (2) screws.

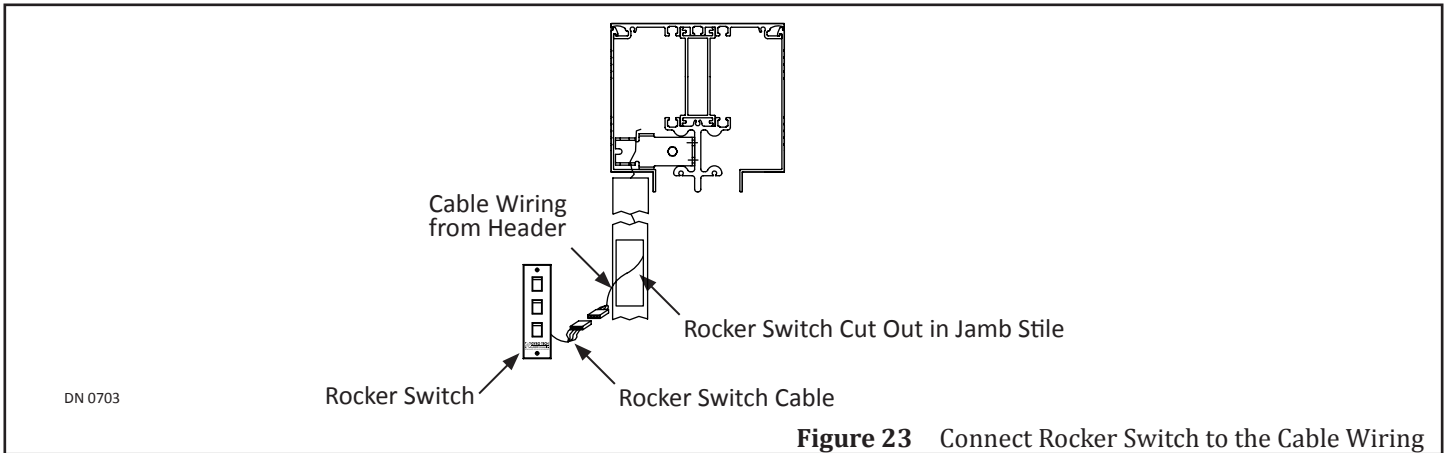

**Figure 23** Connect Rocker Switch to the Cable Wiring

## CHAPTER 10: INSTALL THE THRESHOLD

*Note: Do Not permanently secure the Threshold until the Slide Door has been installed. Doing so may cause misalignment.*

*Note: Extending the Threshold across the entire door opening is optional. To order additional track, please contact customer service at (877) 622-2694.*

Standard Thresholds vary in width and can be installed two different ways:

- ▶ Surface: Installed on the surface of the floor with ramps attached to both sides.
- ▶ Recessed: Installed inside a channel that is 1/2 inch deep x 7 inches wide across the full length of the track.

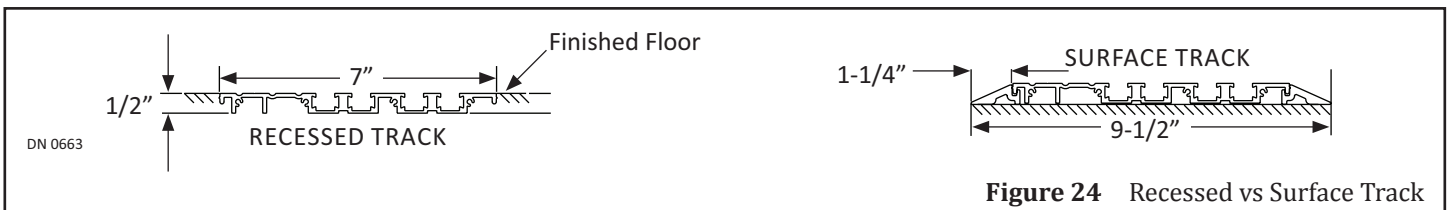

**Figure 24** Recessed vs Surface Track

**Attention:** Threshold must be laid down so the Bumper Channels are located on the side of Slide Door.

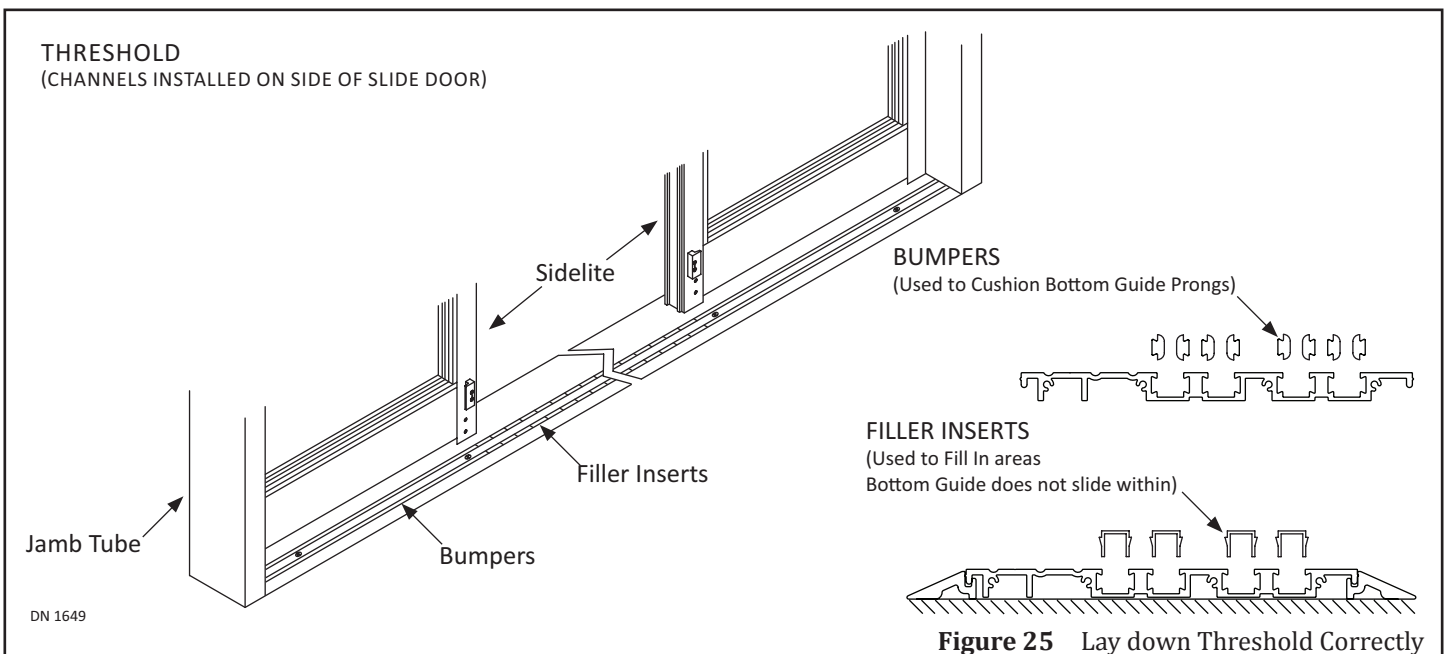

**Figure 25** Lay down Threshold Correctly

**SECTION 10.1: Install the Surface Threshold**

1. On the same side of Door Frame where the Sidelite will be installed, snap a chalk line on the floor from Jamb to Jamb.

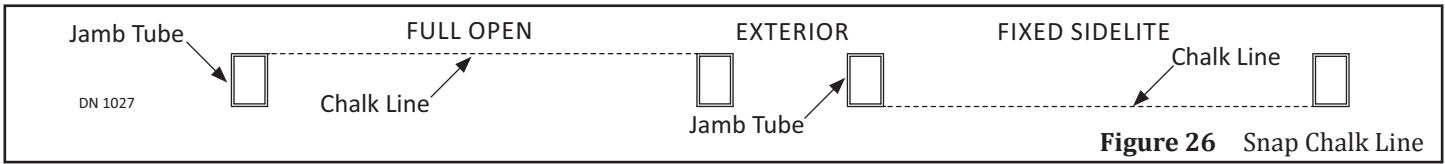

**Figure 26** Snap Chalk Line

**Attention: Do Not center Threshold to Header. Doing so will cause misalignment.**

2. Lay down the Threshold so the Bumper Channels are on same side of Slide Doors.
3. Ensure the Threshold is centered to Jamb Tubes, and full length is flush with the chalk line.
4. Do not permanently install the Surface Threshold until the Slide Doors are completely installed.

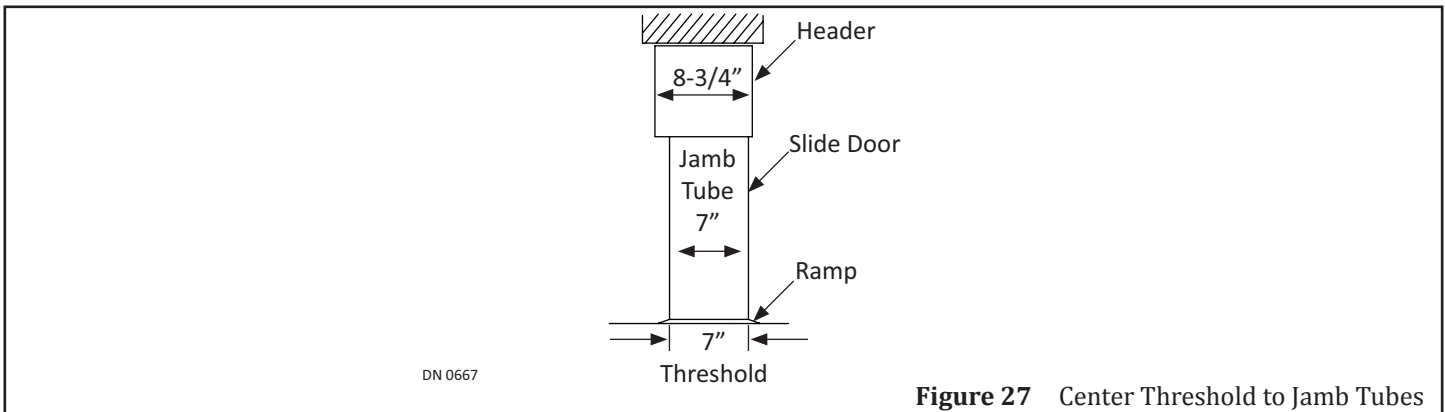

**Figure 27** Center Threshold to Jamb Tubes

**SECTION 10.2: Install the Recessed Threshold**

1. On the same side of Door Frame where the Sidelite will be installed, snap a chalk line on the floor from Jamb to Jamb.
2. Create a channel that is 1/2 inch deep x 7 inches wide x full length of Threshold.
3. Lay down the Threshold so the Bumper Channels are on same side of Slide Doors.
4. Ensure the Threshold is centered to Jamb Tubes, and full length is flush with the chalk line.
5. Do not permanently install the Recessed Threshold until the Slide Doors are completely installed.

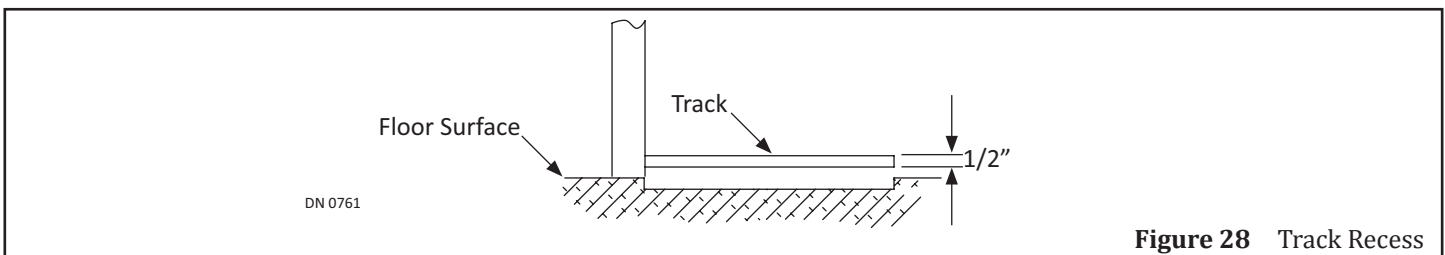

**Figure 28** Track Recess

**CHAPTER 11: INSTALL THE FULL OPEN; SIDELITE**

*FOR FIXED SIDELITE UNITS SKIP TO CHAPTER 14*

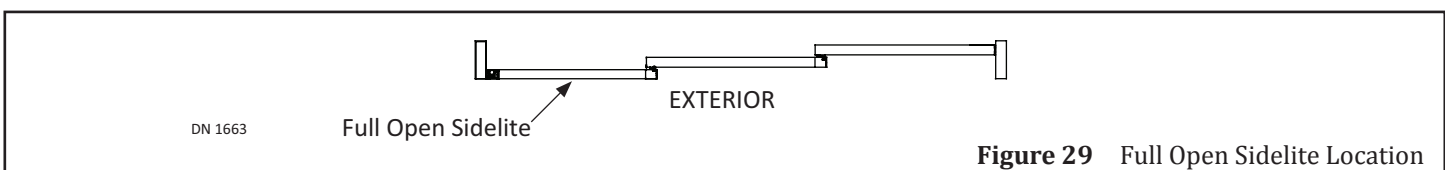
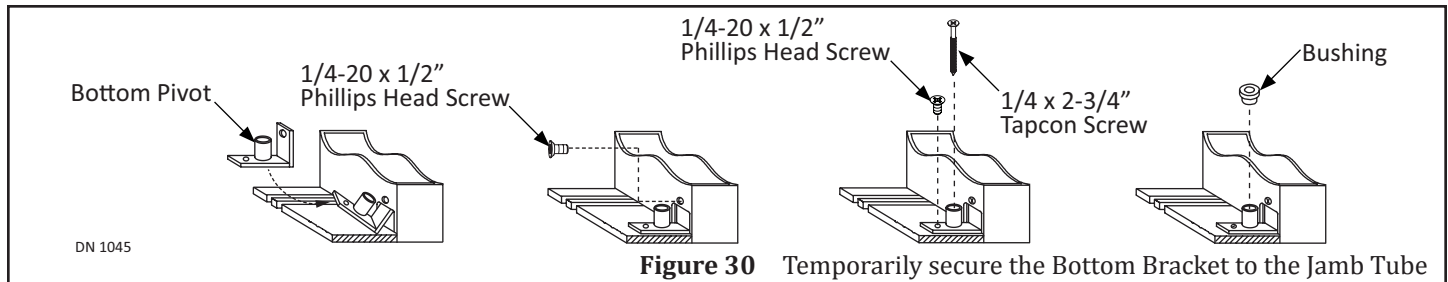

**Figure 29** Full Open Sidelite Location

**SECTION 11.1: Secure the Bottom Pivot to the Jamb Tube**

1. Secure the Bottom Pivot to the Pivot Jamb Tube with (1) 1/4-20 x 1/2 inch Phillips Head screw.

2. Go to the screw hole located in front of the Barrel.
3. Secure the Floor Pivot to the Threshold with (1) 1/4-20 x 1/2 inch Phillips Head Screw.
4. Insert (1) 1/4 x 2-3/4 inch Phillips Head Screw inside the Barrel. Tighten.
5. Cap the Barrel with (1) Bushing.



### SECTION 11.2: Partially Install the Limit Arm

1. Replace the Header Cover.
2. Slide (1) .255 ID x .900 OD x .125 THK Nylon Washer onto (1) 1/4-20 x 1 inch Phillips Head Screw.
3. Obtain the Limit Arm. Go underneath the end. Slide the Screw assembly up into the Screw Hole.
4. Go to the pre-drilled screw hole located at the bottom Lip of Header Cover (on the Pivot Side of Sidelite).
5. Tighten the Screw just enough to keep the Limit Arm assembly from falling out of the hole.
  - a. Limit Arm installation is completed after the Full Open Sidelite is fully installed.

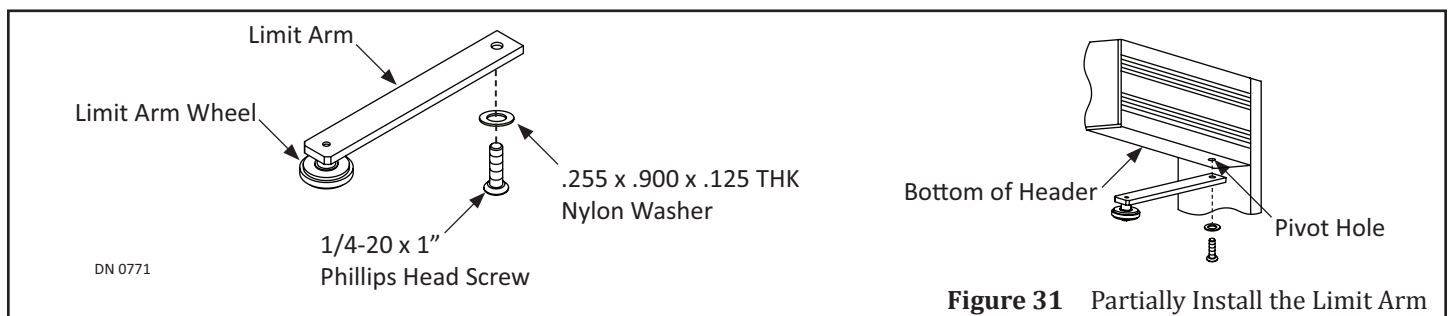

### SECTION 11.3: Install the Full Open Sidelite onto the Upper Pivot and Bottom Pivot

1. Insert the Bottom Pivot (located inside the Pivot Stile), into the Bottom Pivot Barrel.

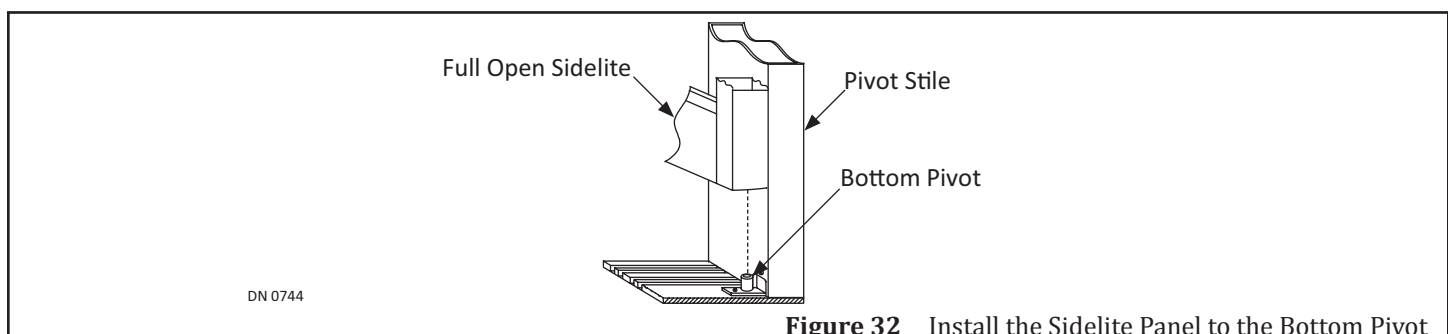

2. Go to the Top Pivot located inside the Pivot Stile. Press down on the Spring Pin to push the Top Pivot down.
3. Align the Top Pivot with the Pivot Hole located at the bottom of Header.
4. Release the Spring Pin to allow the Top Pivot to snap up into the hole. Ensure the Top Pivot fully engages the hole.
  - a. If necessary, use a flathead screwdriver to lift up on the Spring pin until the Pivot Pin is fully seated within the hole.
  - b. Ensure not to pinch Cable Wiring.



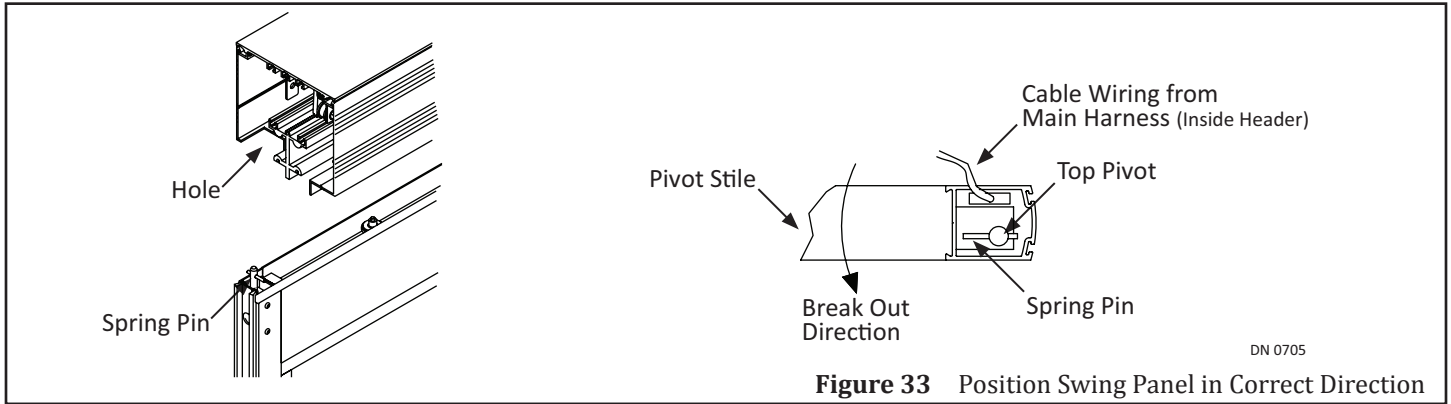

**Figure 33** Position Swing Panel in Correct Direction

**SECTION 11.4: Complete the Installation of the Limit Arm**

1. Swing open the Swing Sidelite 90 degrees. Rest the Limit Arm inside the Top Rail.
2. Fully Open the Sidelite Panel. Fully tighten the 1/4-20 x 1 inch Screw.

**SECTION 11.5: Adjust the Ball Detents**

*Note: Breakout resistance for Ball Detents must meet ANSI Standard A156.10 or Local Codes.*

1. Go to the top of Strike Stile. With a 15/16" Open End wrench, loosen the Nut to raise or lower the Ball Detent so it has light contact with the Bottom Lip of Header Cover.
2. Open and close the Sidelite several times to score the surface. Mark where the Score intersects the center groove.
3. Drill a screw hole through the Bottom Lip of Header Cover with a 1/4 inch drill bit. Countersink the screw hole 3/8 inch x 82°.

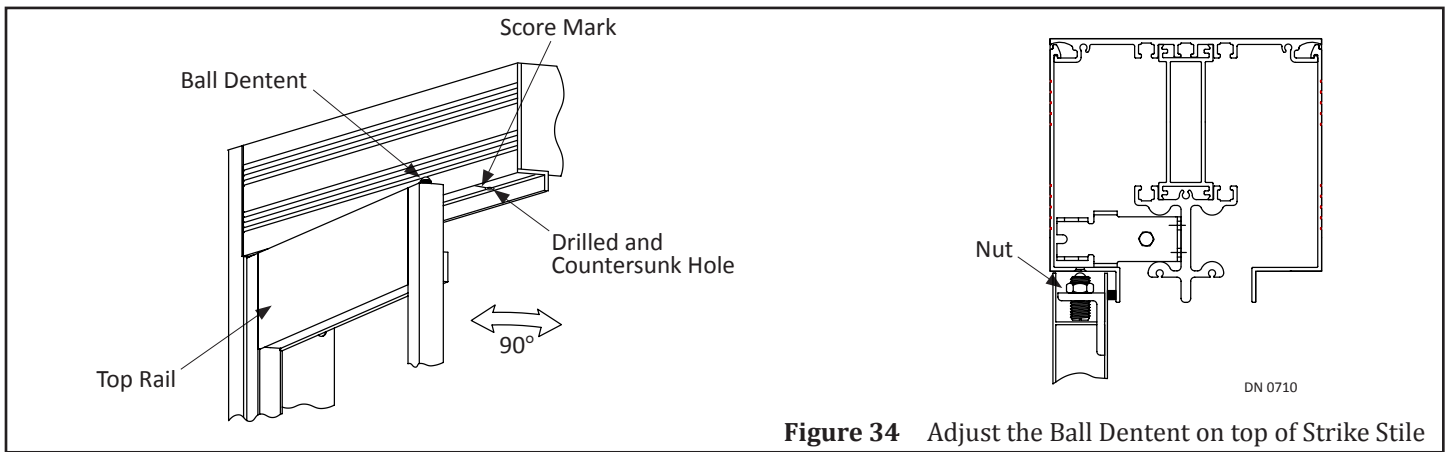

**Figure 34** Adjust the Ball Dentent on top of Strike Stile

4. Go to the bottom of Strike Stile. With a 15/16" Open End wrench, loosen the Nut to raise or lower the Ball Detent so it has light contact with the Threshold.
5. Open and close the Swing Door several times to score the surface. Mark where the Score intersects the center groove.
6. With a 1/4 inch diameter drill bit, drill a hole through the Threshold (Just deep enough for the Ball Detent to fit within).
7. Countersink the screw hole to be 1/4 inch x 82°.

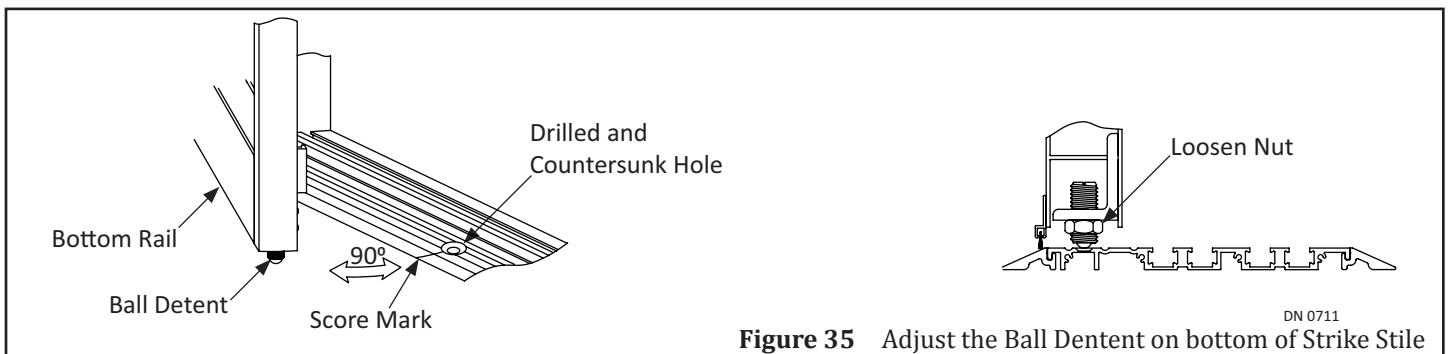

**Figure 35** Adjust the Ball Dentent on bottom of Strike Stile

8. Close, and then Break Open the Swing door to test fit for both Ball Detents.
  - a. To adjust the fit, increase the size of the hole and countersink.
  - b. Do Not over-drill the hole. If hole is overdrilled the Threshold will need to be replaced.
  - c. For additional travel, remove the Ball Detent Bracket to lower or raise the Ball Detent.
9. Please refer to "CHAPTER 21: Adjustments" to adjust the Sidelite.

## CHAPTER 12: INSTALL THE FULL OPEN; TRAIL DOOR

**CAUTION** Do not test Breakout until all adjustments are made and doors are secured.

*Note: The Trail Door must always be installed on opposite side of the DS-150 Drive Pulley.*

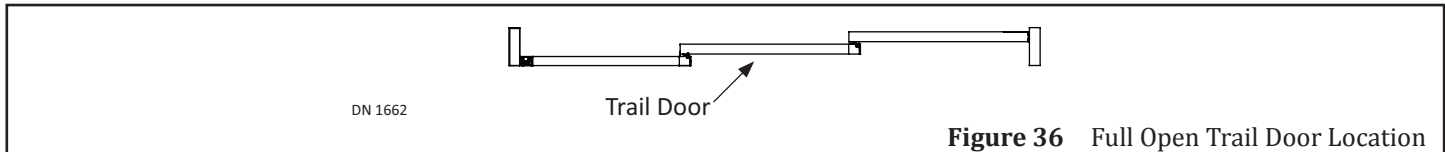

**Figure 36** Full Open Trail Door Location

1. Swing open the Sidelite Panel 90°.
2. Go to the Header Cover on the **EXTERIOR** side of Building. Open and remove the Cover.
  - a. When the Cover is opened, the Limit Arm will lift out of the Top Rail of the Sidelite Panel.
  - b. Allow the Limit Arm to move with the Cover.
3. Close the Sidelite Panel.
4. Cover the Sidelite Panel with cardboard on the side that will face the Trail door.
5. Go to the Carrier on top of the Trail Door.
6. Loosen (1) 5/16-18 Whiz Lock Nut on each Roller by inserting (1) 5/32" Allen wrench into the exposed end of a Roller Axle. Hold the 5/32 inch Allen wrench in place to keep the Roller Axle stationary. At the same time, loosen (1) 5/16-18 Whiz Lock nut with a 1/2 inch Open End Wrench.

**CAUTION** Do not rotate the Roller Axle counter-clockwise. Doing so will unthread the Axle from the Roller Assembly.

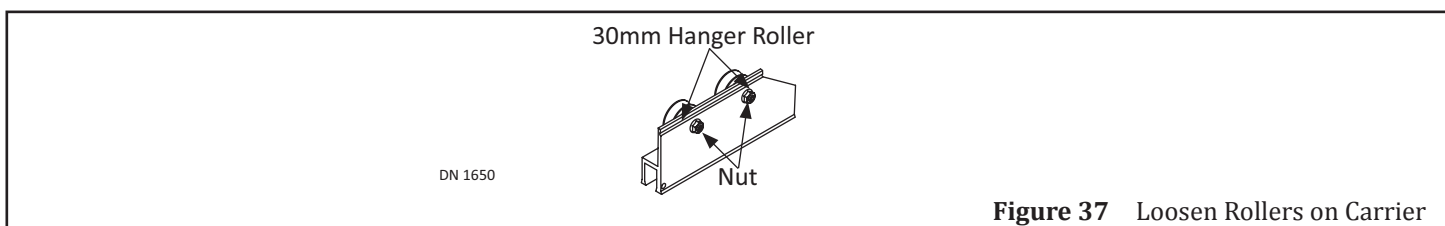

**Figure 37** Loosen Rollers on Carrier

7. To make it easier for rollers to "catch onto the track", slightly tilt and lift the Trail Door into the Header, and onto the Track.

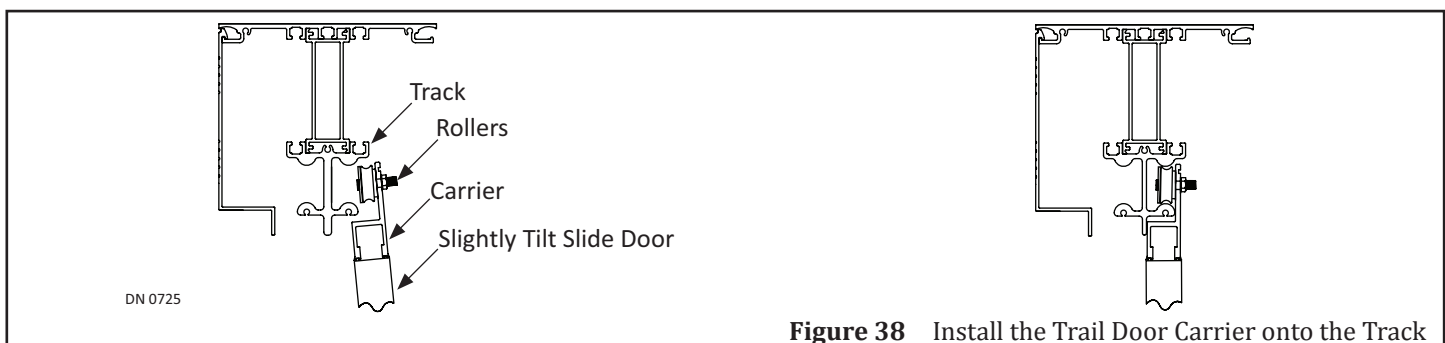

**Figure 38** Install the Trail Door Carrier onto the Track

8. Secure the Belt Clip to the Carrier with (2) 1/4-20 x 1 inch Whizlock screws.

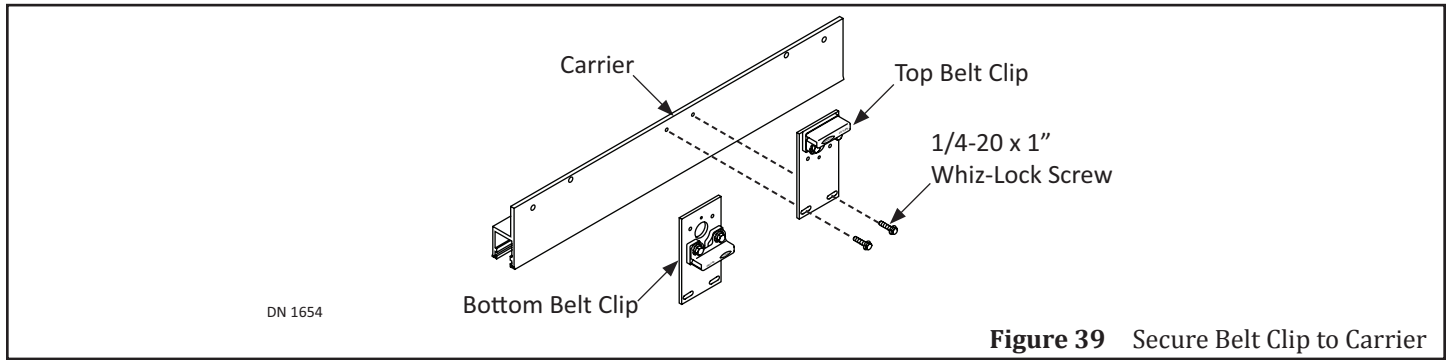

**Figure 39** Secure Belt Clip to Carrier

9. Lift up the Prongs located on the pre-installed Bottom Guide. Align and drop the Prongs into the Threshold accordingly.

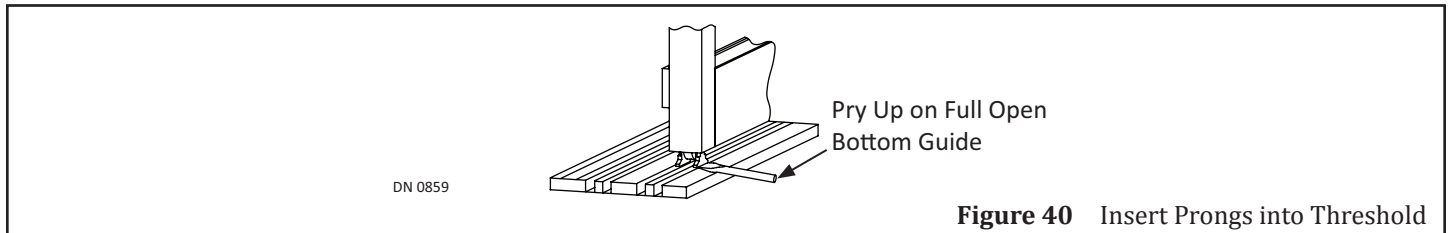

**Figure 40** Insert Prongs into Threshold

10. Adjust the Belt Clip so the Fully Open position for the Trail Door stops 1 inch away from the Pivot Jamb.

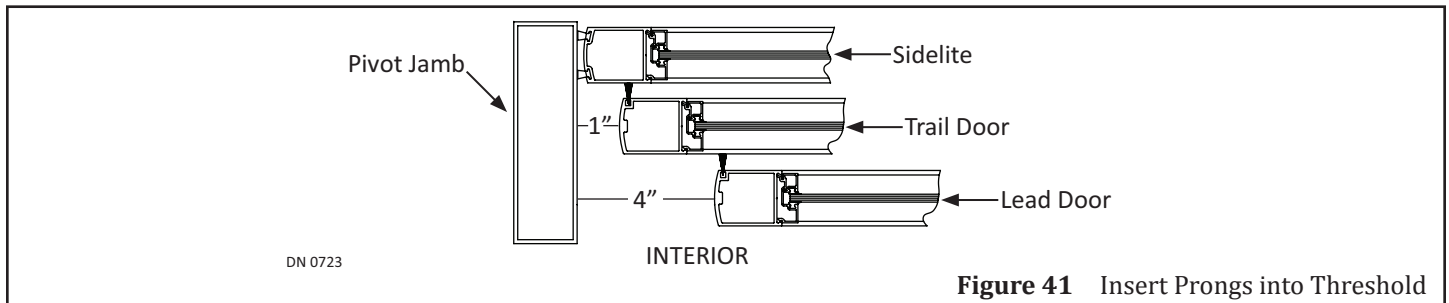

**Figure 41** Insert Prongs into Threshold

11. Please refer to "CHAPTER 21: Adjustments" to adjust the Trail Door.

### CHAPTER 13: INSTALL THE FULL OPEN; LEAD DOOR

**CAUTION**

Do not test Breakout until all adjustments are made and doors are secured.

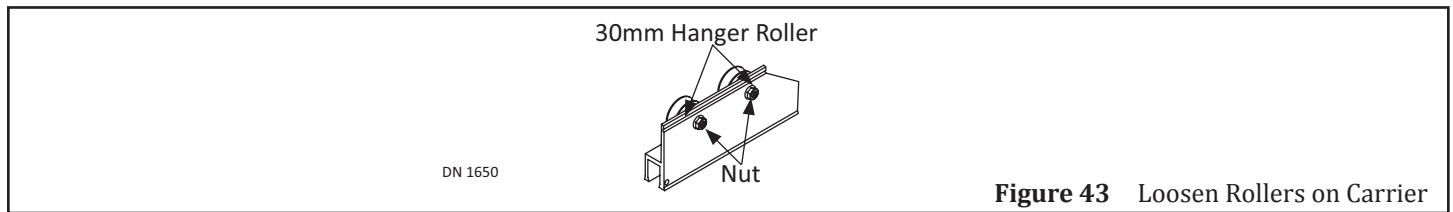

**Figure 42** Full Open Lead Door Location

1. Cover the Trail door with cardboard on the side that will face the Lead door.
2. Go to the Carrier on top of the Lead Door.
3. Loosen (1) 5/16-18 Whiz Lock Nut on each Roller by inserting (1) 5/32" Allen wrench into the exposed end of a Roller Axle. Hold the 5/32 inch Allen wrench in place to keep the Roller Axle stationary. At the same time, loosen (1) 5/16-18 Whiz Lock nut with a 1/2 inch Open End Wrench.

**CAUTION**

Do not rotate the Roller Axle counter-clockwise. Doing so will unthread the Axle from the Roller Assembly.



**Figure 43** Loosen Rollers on Carrier

4. Go to the Header Cover on the **INTERIOR** side of Building. Open and remove the Cover.
5. To make it easier for rollers to “catch onto the track”, slightly tilt and lift the Lead Door into the Header, and onto the Track.

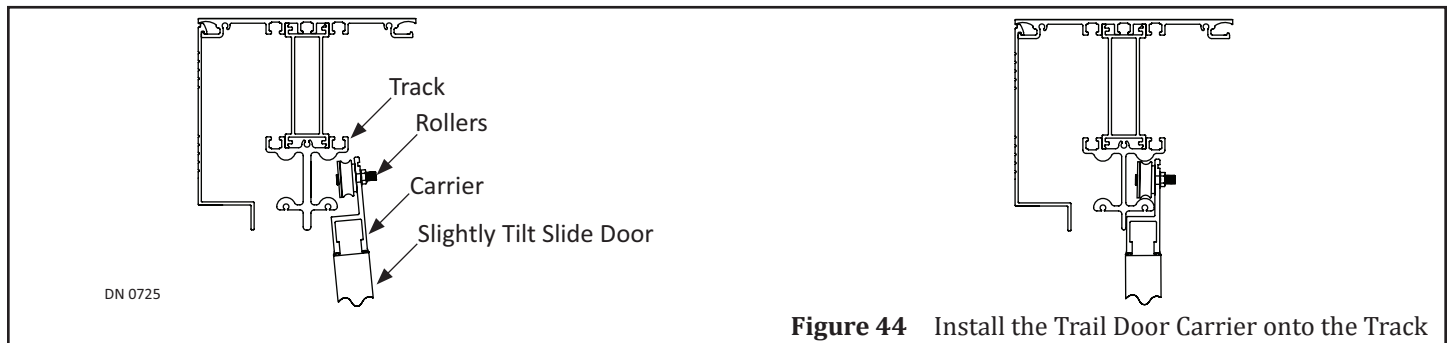

**Figure 44** Install the Trail Door Carrier onto the Track

6. Secure the Belt Clip to the Carrier with (2) 1/4-20 x 1 inch Whizlock screws.

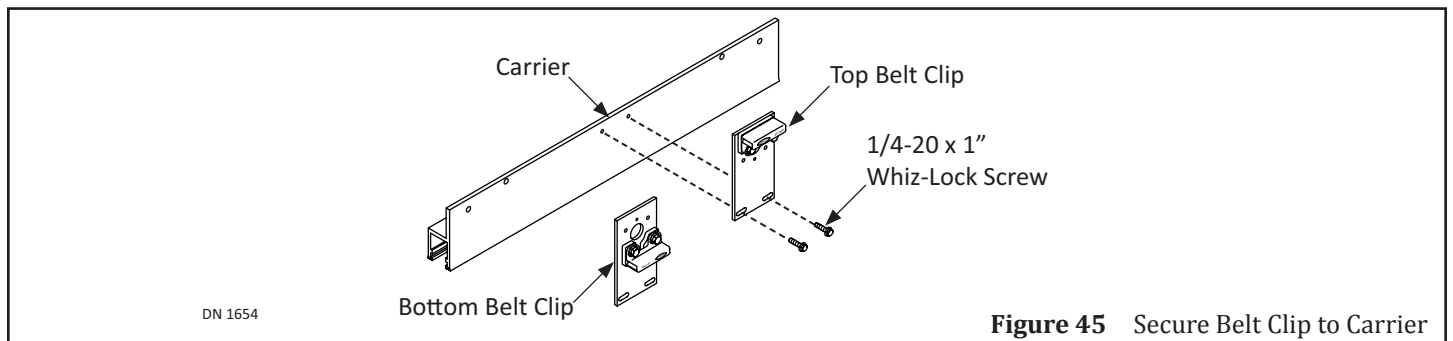

**Figure 45** Secure Belt Clip to Carrier

7. Lift up the Prongs located on the pre-installed Bottom Guide. Align and drop the Prongs into the Threshold accordingly.

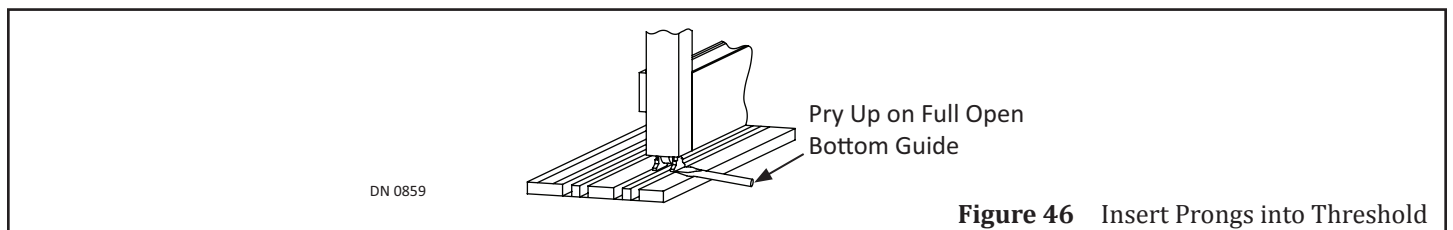

**Figure 46** Insert Prongs into Threshold

8. Adjust the Door Stop so the Fully Open position for the Lead Door stops 4 inches away from the Pivot Jamb.

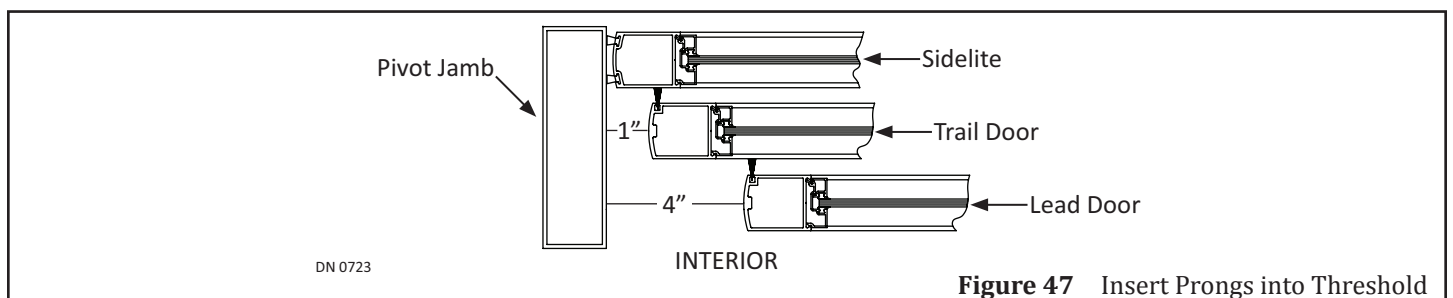
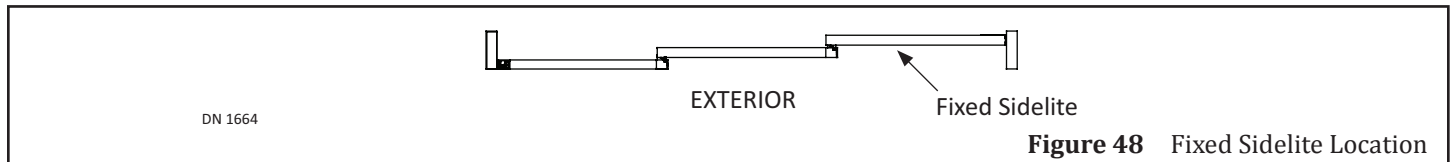

**Figure 47** Insert Prongs into Threshold

9. Please refer to “CHAPTER 21: Adjustments” to adjust the Lead Door.

## CHAPTER 14: INSTALL THE FIXED; SIDELITE

*FOR FULL OPEN SLIDE DOORS SKIP TO CHAPTER 17*



1. Go to the Pivot Jamb Tube. Locate (2) pre-installed Mounting Brackets.
2. Slide the Sidelite Panel onto the Mounting Brackets. The Mounting Bracket must go through the cutout clearance and be flush against the inside wall.
3. Temporarily secure the Sidelite Panel to the Mounting Brackets with 1/4-20 x 1/2 inch Socket Head Screws.

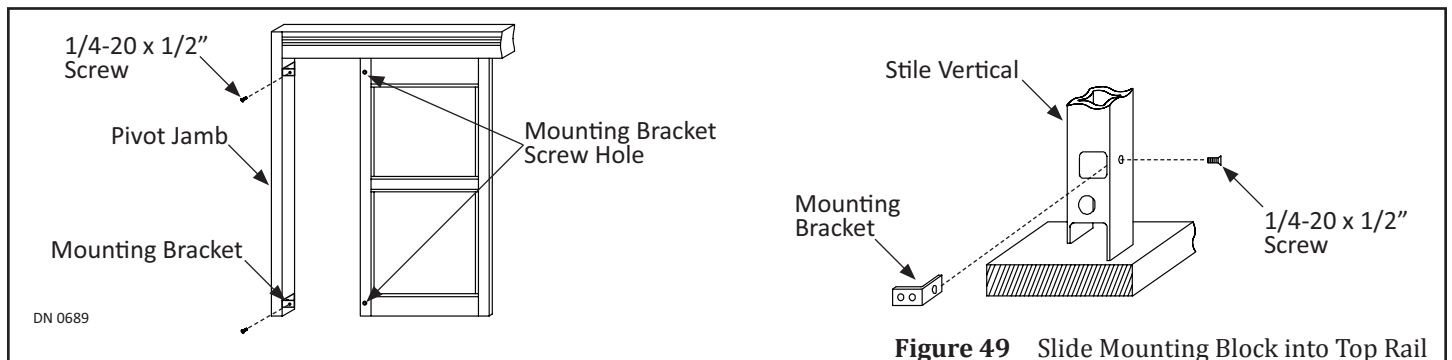

4. Snap a chalk line between Jamb tubes in front of Sidelite Panel.
  - a. If the Sidelite Panel runs parallel to the chalk line it is square.
  - b. If the Sidelite Panel is not parallel to the chalk line make necessary adjustments until it is.

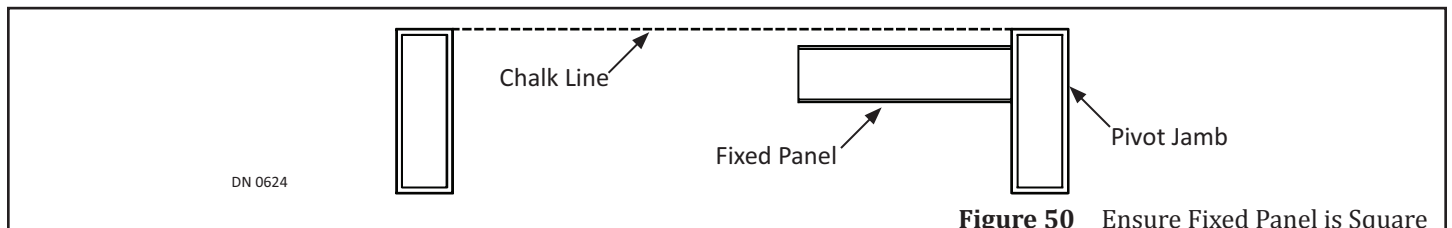

5. Go to the bottom of the Fixed Sidelite, Strike Stile. Remove the End Cap Cover and End Cap Bracket.

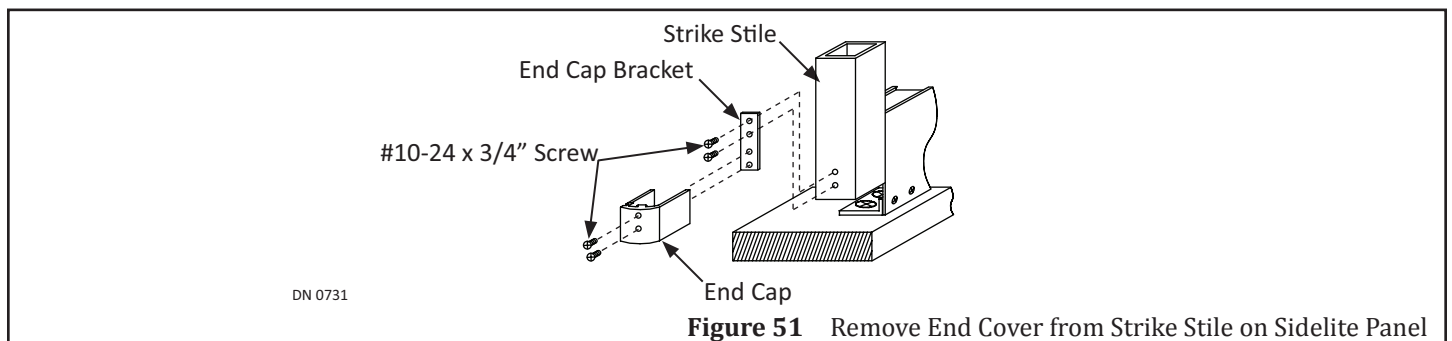

6. Slide the Floor Mounting Bracket underneath the Bottom Rail.
7. Temporarily secure the Mounting Bracket to the Sidelite Panel with (2) #10-24 Flat Head screws.
8. Trace the Mounting Bracket onto the flat surface while holding the Sidelite Panel parallel to the chalk line.
9. Remove the Sidelite from all Mounting Brackets.
10. Mark and drill (2) #14 x 1-1/2 inch screw holes into the floor at least 1-1/2 inch deep.

11. Insert (1) Anchor into each hole. Secure the Floor Mounting Bracket to the floor with (2) #14 x 1-1/2 inch Flat Head screws.
12. Permanently secure the Sidelite Panel to all (3) Mounting Brackets.

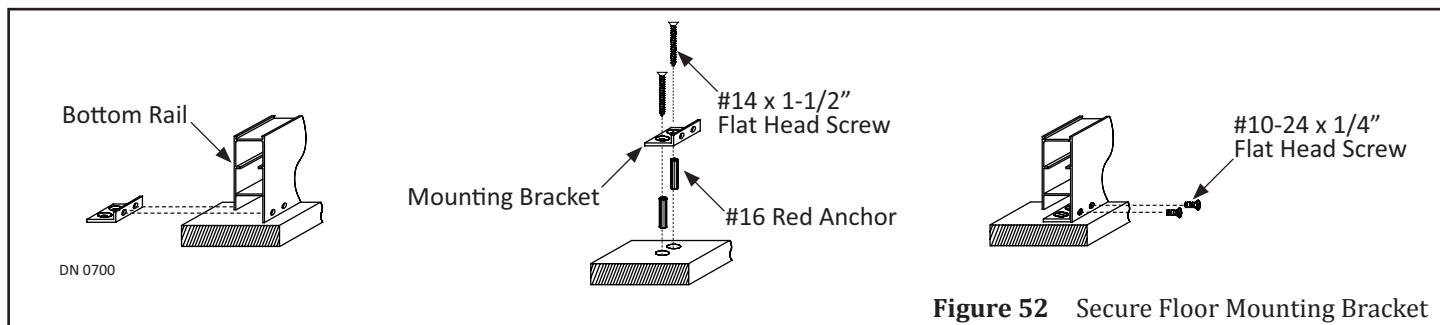

**Figure 52** Secure Floor Mounting Bracket

13. Secure the Top Mounting Bracket to the Strike Stile with (1) 1/4-20 x 1/2 inch Flat Head screw.
  - a. There will be a gap between the bottom face of the Mounting Bracket and the top end of the Strike Stile.
14. Temporarily replace and secure the Header Cover. The Cover will swing under the Mounting Bracket.

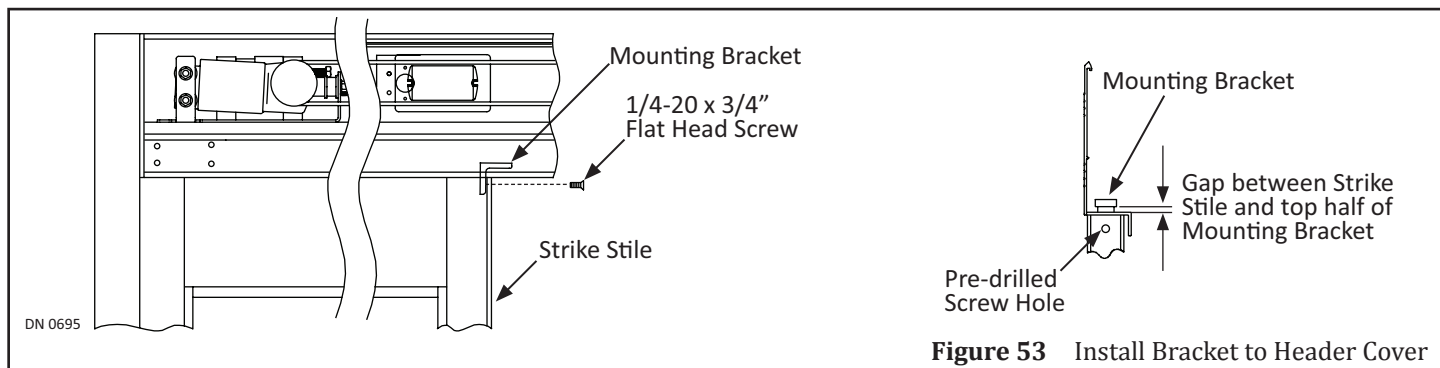

**Figure 53** Install Bracket to Header Cover

15. Insert (1) Drill Bit through the pre-drilled hole located underneath the bottom Lip of Cover; until the Drill Bit Butts up against the bottom face of the Mounting Bracket.
16. Drill (1) .150 screw hole into the Mounting Bracket.

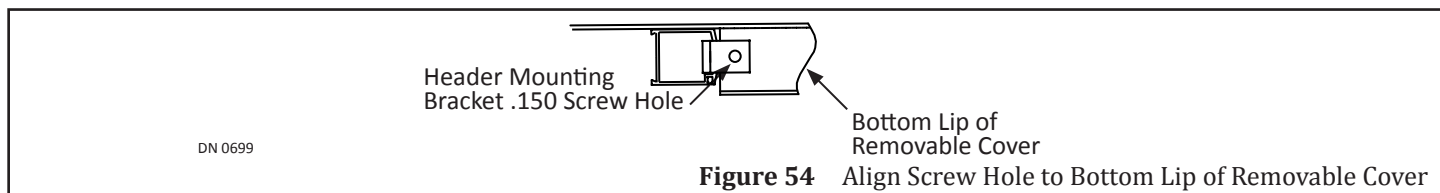

**Figure 54** Align Screw Hole to Bottom Lip of Removable Cover

17. Temporarily secure the Top Mounting Bracket to the bottom Lip of the Header Cover with (1) #8-32 x 5/8 inch Flat Head screw. The Header Cover will need to be removed before installation is complete.

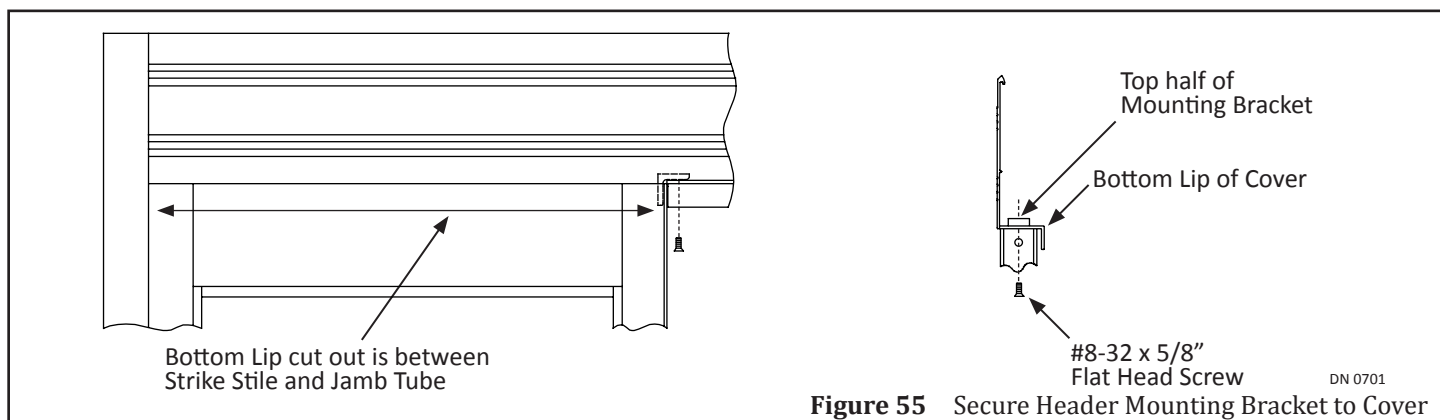

**Figure 55** Secure Header Mounting Bracket to Cover

## CHAPTER 15: INSTALL THE FIXED SIDELITE; TRAIL DOOR

**CAUTION**

Do not test Breakout until all adjustments are made and doors are secured.

Note: The Trail Door must always be installed on opposite side of the DS-150 Drive Pulley.

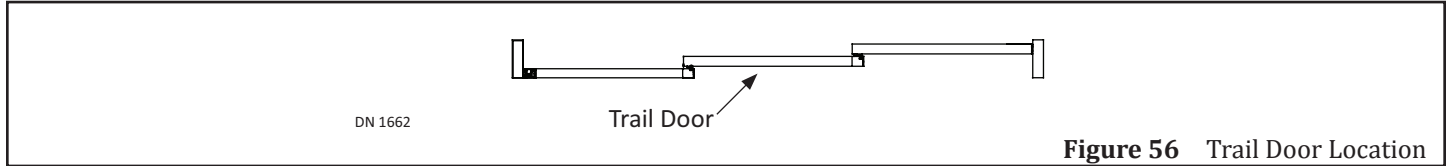

Figure 56 Trail Door Location

1. Open, and remove the Header Cover on the INTERIOR side of Building.

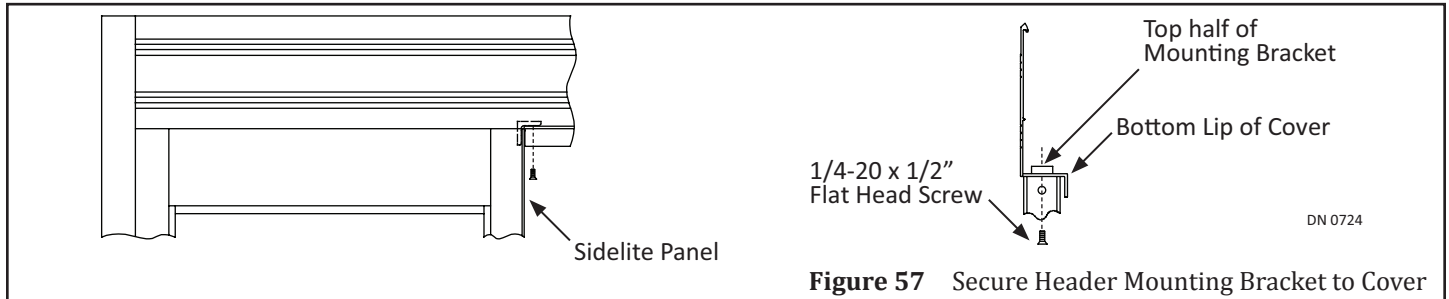

Figure 57 Secure Header Mounting Bracket to Cover

2. Cover the Fixed Sidelite with cardboard on the side that will face the Trail door.
3. Go to the Carrier on top of the Trail Door.
4. Loosen (1) 5/16-18 Whiz Lock Nut on each Roller by inserting (1) 5/32" Allen wrench into the exposed end of a Roller Axle. Hold the 5/32 inch Allen wrench in place to keep the Roller Axle stationary. At the same time, loosen (1) 5/16-18 Whiz Lock nut with a 1/2 inch Open End Wrench.

**CAUTION**

Do not rotate the Roller Axle counter-clockwise. Doing so will unthread the Axle from the Roller Assembly.

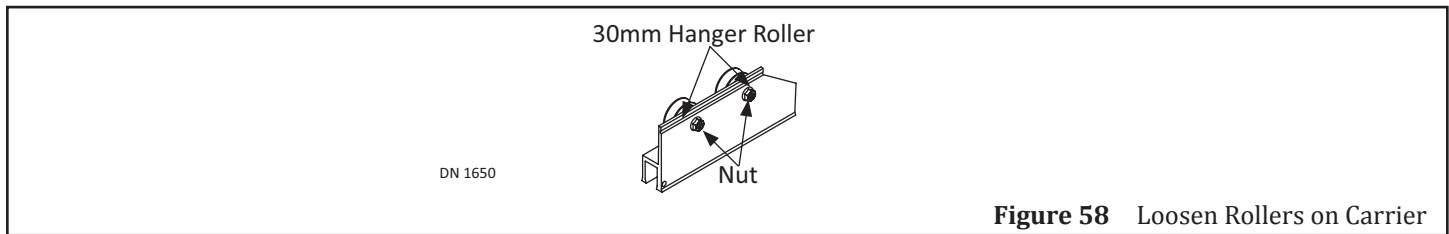

Figure 58 Loosen Rollers on Carrier

5. To make it easier for rollers to "catch onto the track", slightly tilt and lift the Trail Door into the Header, and onto the Track.

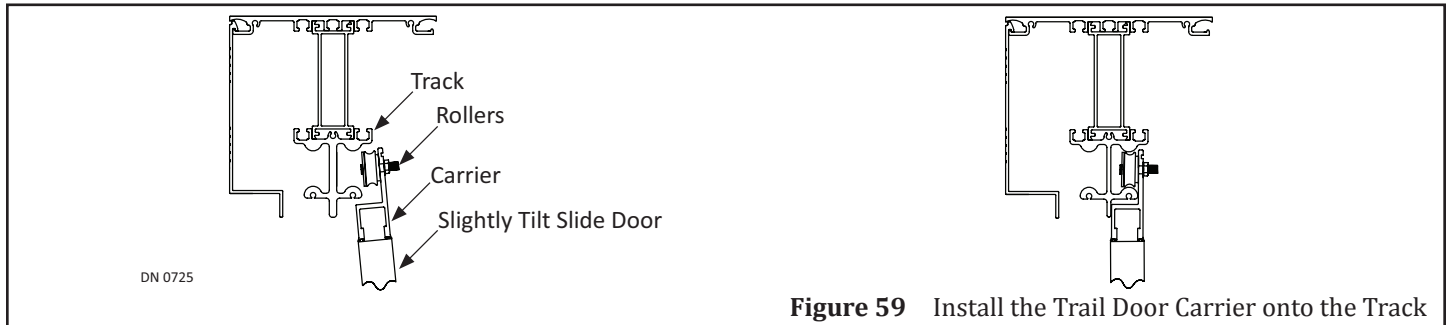
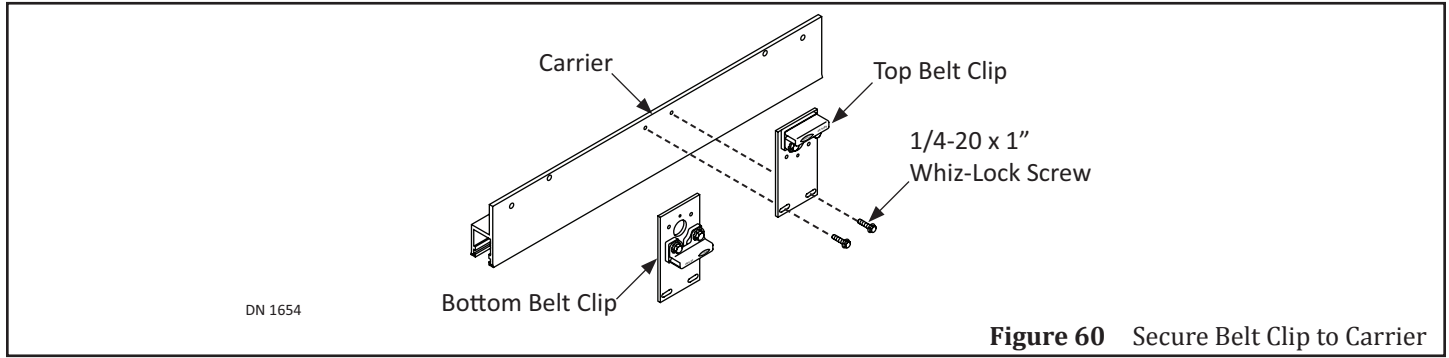
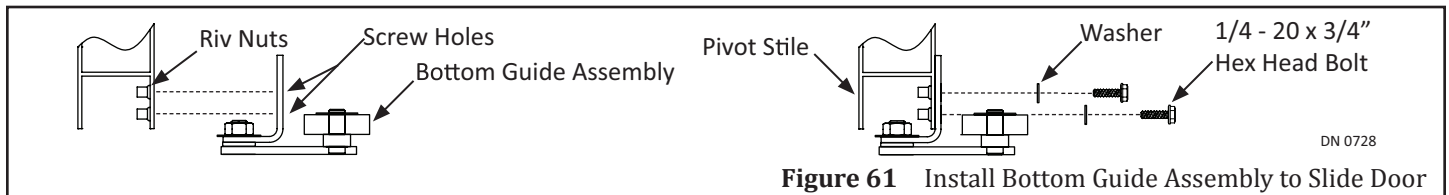

Figure 59 Install the Trail Door Carrier onto the Track

6. Secure the Belt Clip to the Carrier with (2) 1/4-20 x 1 inch Whizlock screws.



7. Obtain the Bottom Guide. For Bi-Part Slide doors a Left Hand and a Right Hand Bottom Guide will be provided.
8. Secure the Bracket part of the Bottom Guide to the **Pivot** Stile with (2) 1/4 inch Washers and (2) 1/4 - 20 x 1 inch Screws.



9. Slide the Bottom Guide Rollers inside the Fixed Sidelite, Bottom Rail until it is at least in, halfway over to the Pivot Stile.

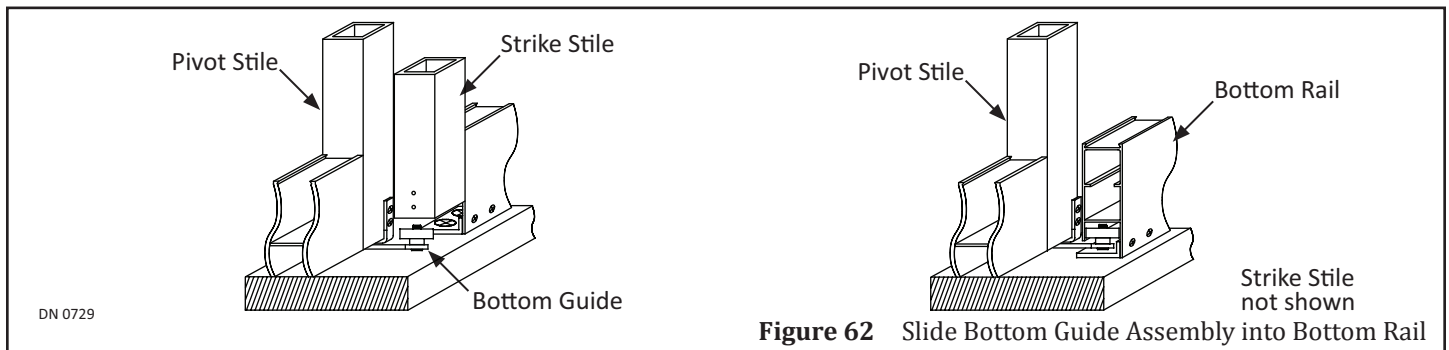

10. Replace and secure the End Cap Bracket to the **Strike** Stile with (4) #10-24 x 3/4 inch Flat Head screws.

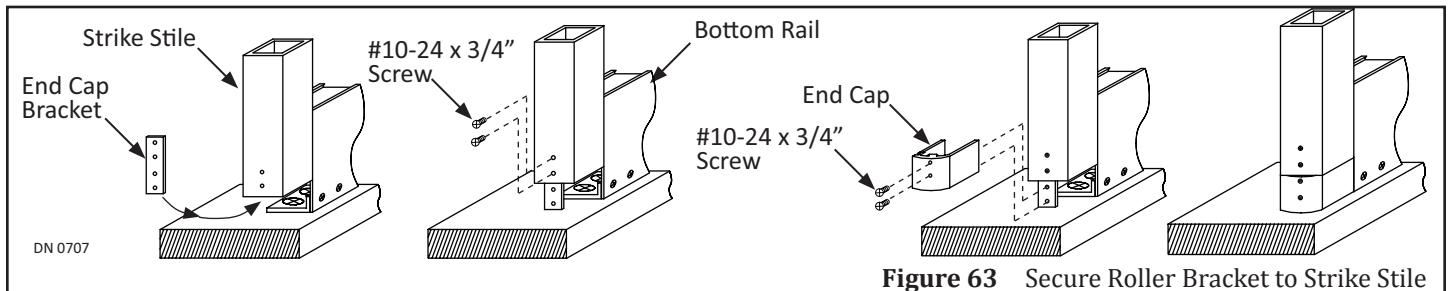

11. Adjust the Belt Clip so the Fully Open position for the Trail Door stops 1 inch away from the Pivot Jamb.

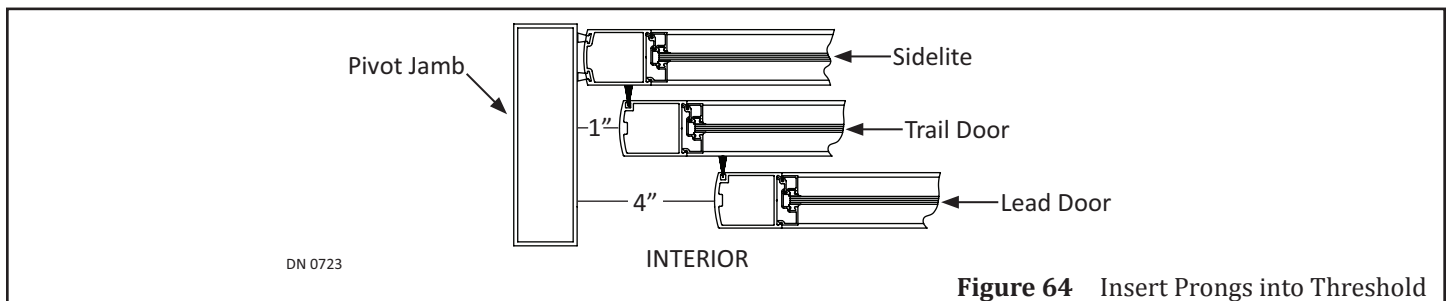



- 12. Please refer to "CHAPTER 21: Adjustments" to adjust the Trail Door.
- 13. Proceed to install the Lead Door.

### CHAPTER 16: INSTALL THE FIXED SIDELITE; LEAD DOOR

**CAUTION**

Do not test Breakout until all adjustments are made and doors are secured.

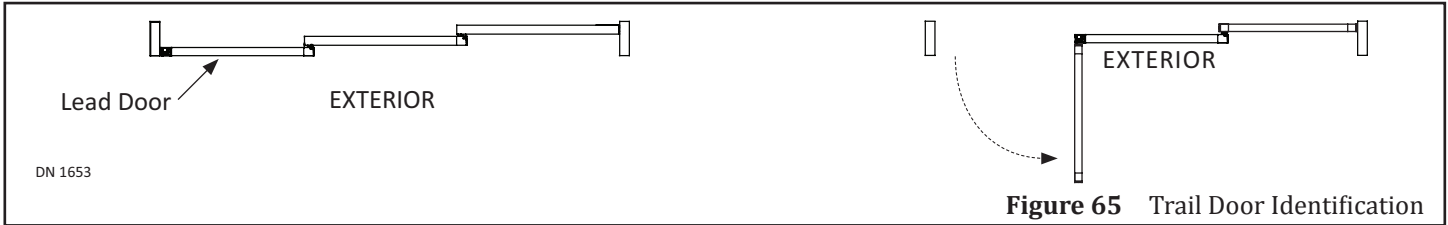

Figure 65 Trail Door Identification

- 1. Open, and remove the Header Cover on the EXTERIOR side of Building.
- 2. Cover the Trail door with cardboard on the side that will face the Lead door.
- 3. Go to the Carrier on top of the Lead Door.
- 4. Loosen (1) 5/16-18 Whiz Lock Nut on each Roller by inserting (1) 5/32" Allen wrench into the exposed end of a Roller Axle. Hold the 5/32 inch Allen wrench in place to keep the Roller Axle stationary. At the same time, loosen (1) 5/16-18 Whiz Lock nut with a 1/2 inch Open End Wrench.

**CAUTION**

Do not rotate the Roller Axle counter-clockwise. Doing so will unthread the Axle from the Roller Assembly.

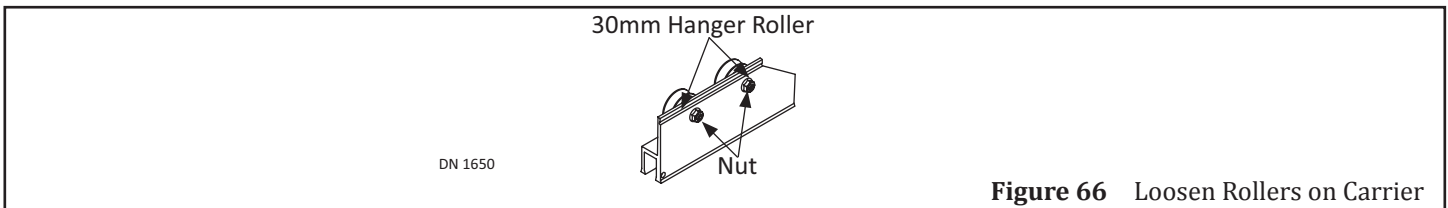

Figure 66 Loosen Rollers on Carrier

- 5. To make it easier for rollers to "catch onto the track", slightly tilt and lift the Trail Door into the Header, and onto the Track.

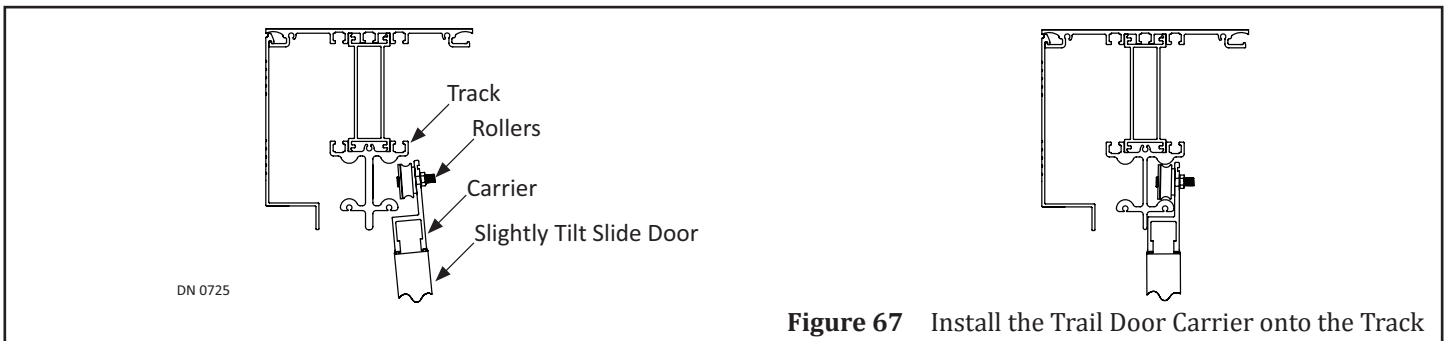

Figure 67 Install the Trail Door Carrier onto the Track

- 6. Secure the Belt Clip to the Carrier with (2) 1/4-20 x 1 inch Whizlock screws.

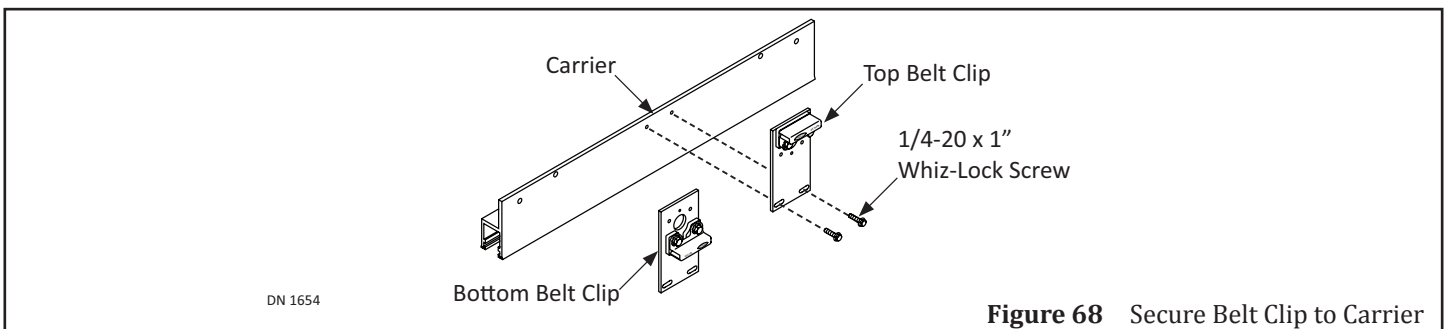
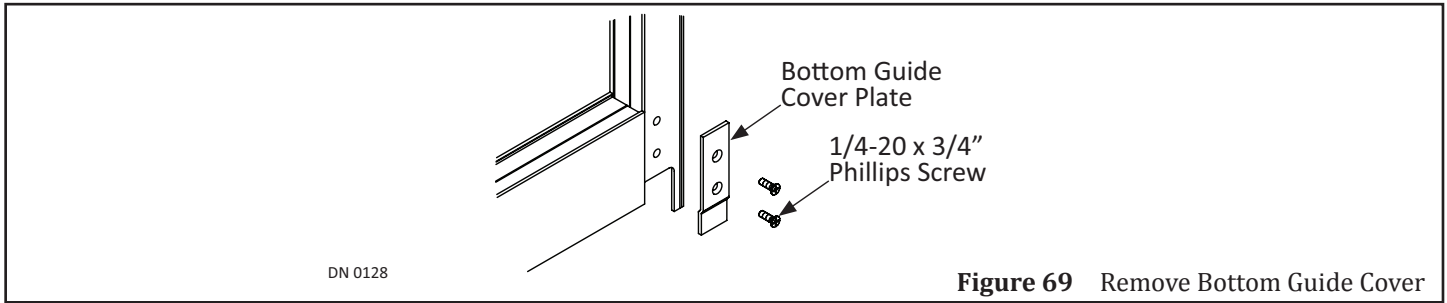

Figure 68 Secure Belt Clip to Carrier

7. Go to the bottom of Trail Door Strike Stile. Remove the Bottom Guide Cover Plate. Set aside.



**Figure 69** Remove Bottom Guide Cover

8. Obtain the Bottom Guide.
  - a. For Bi-Part Slide doors a Left Hand and a Right Hand Bottom Guide will be provided.
9. Install the Bottom Guide Assembly by sliding (2) rollers into the Bottom Rail of the Trail door so the Bracket sticks out from underneath (in direction of where the Lead door is to be installed).
10. Use the Bracket to slide the Bottom Guide Double Roller Assembly towards the Pivot Stile.

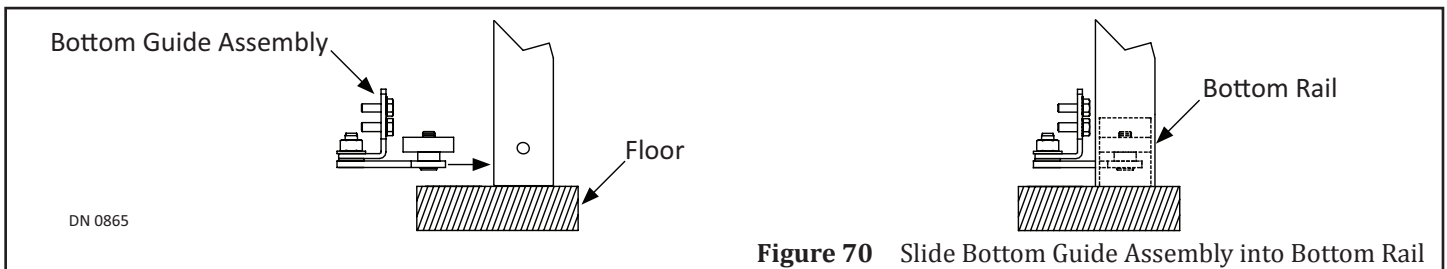

**Figure 70** Slide Bottom Guide Assembly into Bottom Rail

11. Secure the Bracket part of the Bottom Guide to the Pivot Stile of the lead Door with (2) 1/4 inch Washers and (2) 1/4 - 20 x 1 inch Screws.

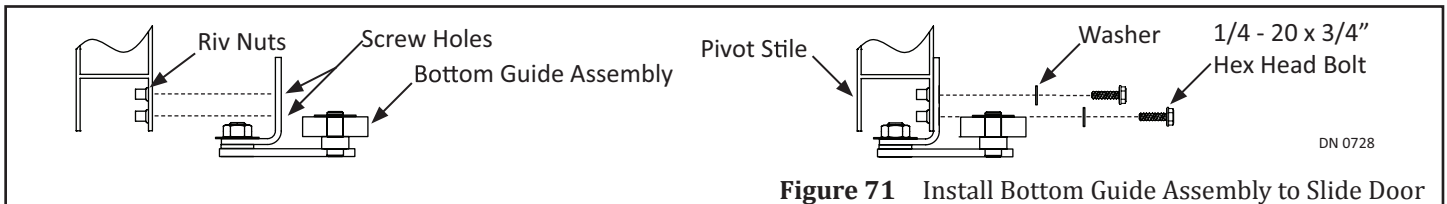

**Figure 71** Install Bottom Guide Assembly to Slide Door

12. Please refer to "CHAPTER 21: Adjustments" to adjust the Lead Door.
13. Adjust the Door Stop so the Fully Open position for the Lead Door stops 4 inches away from the Pivot Jamb.

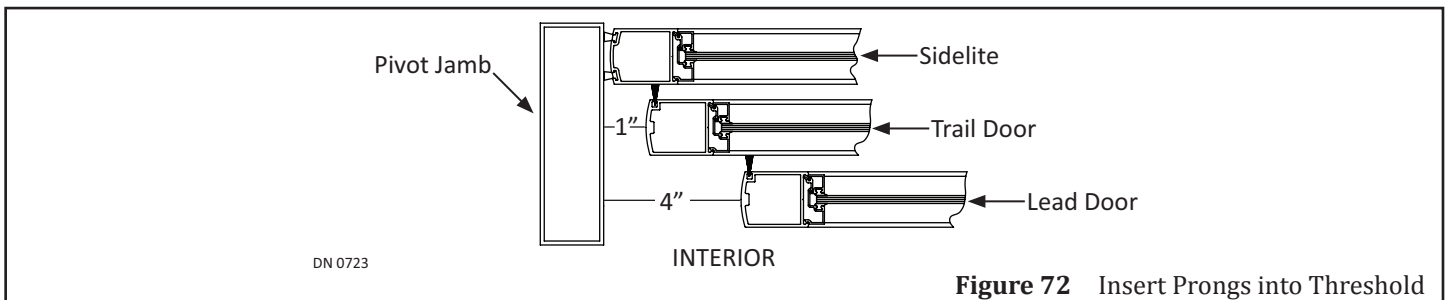
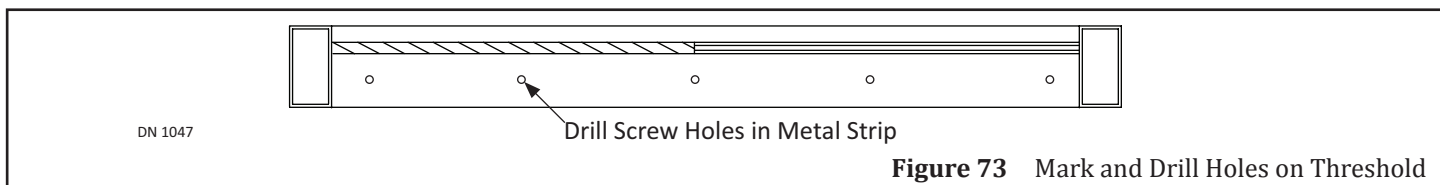

**Figure 72** Insert Prongs into Threshold

14. Replace and secure both Header Covers.

## CHAPTER 17: PERMANENTLY INSTALL THE THRESHOLD

1. Go to each end of Threshold. Mark and drill (1), 1/4 inch hole approximately 4" from each edge.
2. Mark and drill 1/4 inch holes to be evenly spaced.



3. With a 1/4 inch masonry drill bit, drill through the Threshold and into the floor no less than 1-1/2 inch deep.
4. Secure the Threshold with Fasteners not provided by NABCO.

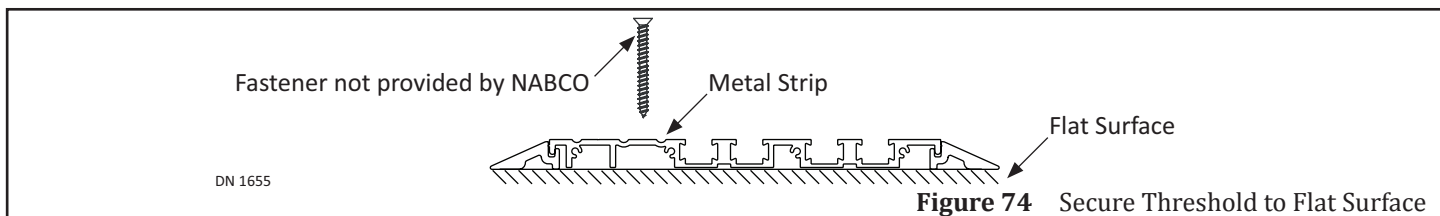

### SECTION 17.1: Threshold Maintenance

1. Check for wear of Bottom Guide Roller and Bumpers inserted within Threshold Channels.
2. Listen for squeaking/grinding noise.
3. Look for dirt/debris/excessive build-up. If dirt/debris/excessive build-up is found.
  1. Vacuum to remove loose material.
  2. Wipe off the Threshold.
  3. Use (1) slotted Screw Driver to remove dirt/debris and/or excessive build-up located within Threshold Channels.
4. Inspect weekly and daily during winter as snow and ice can build up.

## CHAPTER 18: INSTALL WEATHERING

### SECTION 18.1: Full Open Units

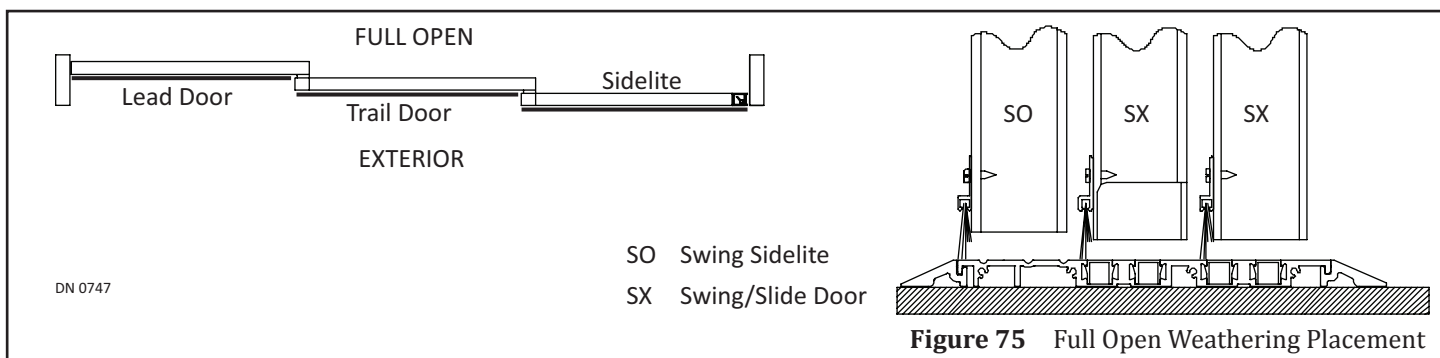

1. If necessary, slide the Weathering into each Brush Holder. Cut off any excess brush.
2. Go to the **EXTERIOR** side of building.
3. Break Open the Sidelite. Secure (1) Brush Holder with #6 x 1/2 inch self tapping screws to the Bottom Rail.
  - a. It is recommended to leave at least a 1/8 inch gap between the Brush Holder and Pivot Stile, while allowing 1/8 inch Weathering to extend past the Brush Holder so the gap is filled.
4. Break Open the Trail Door. Secure (1) Brush Holder with #6 x 1/2 inch self tapping screws to the Bottom Rail.
5. Break Open the Lead Door. Secure (1) Brush Holder with #6 x 1/2 inch self tapping screws to the Bottom Rail.

## SECTION 18.2: Fixed Sidelite Units

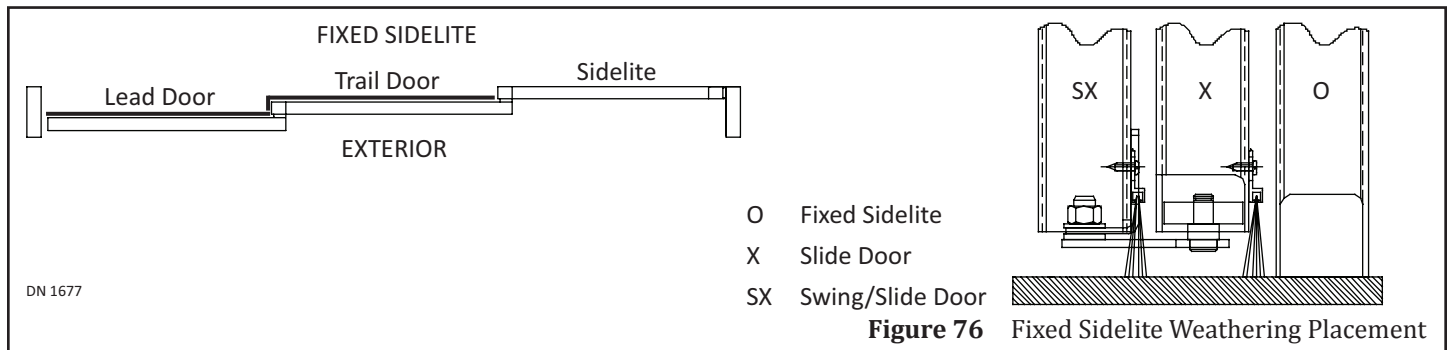

1. If necessary, slide the Weathering into each Brush Holder. Cut off any excess brush.
2. Go to the **INTERIOR** side of building.
3. Break Open the Lead Door. Secure (1) Straight Brush Holder with #6 x 1/2 inch self tapping screws to the Bottom Rail.
4. Break Open the Trail Door. Secure (1) Bent Brush Holder with #6 x 1/2 inch self tapping screws to the Bottom Rail.
  - a. The Bent End of Brush Holder wraps around the Strike Stile.

## SECTION 18.3: Caulk the Door Frame to Rough Opening

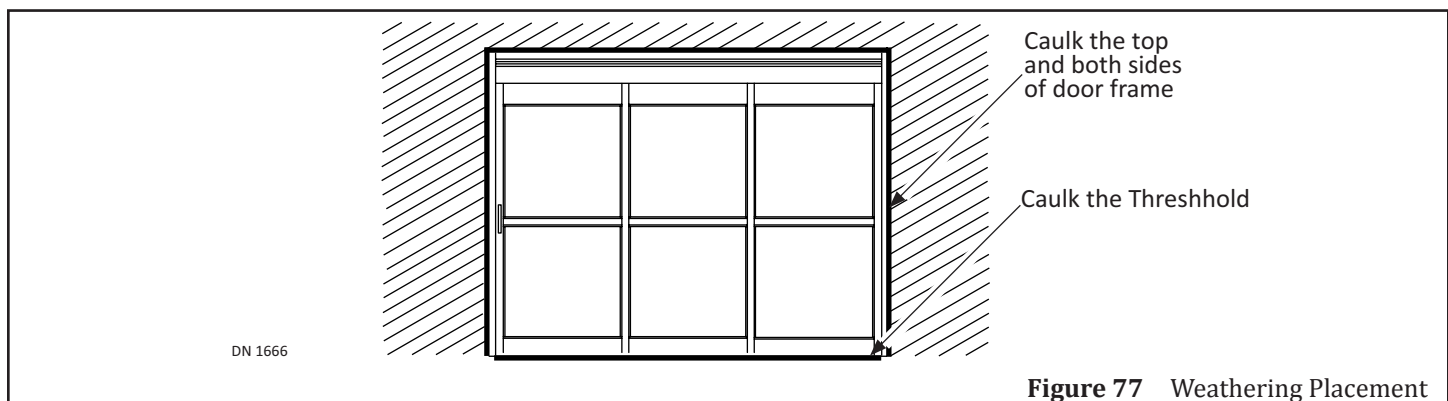

1. Ensure the entire Door Frame is properly secured to the Rough Opening.
2. Apply caulking bead between the Door Frame and Rough Opening on both the interior side, and exterior side.
3. Apply caulking bead to the Threshold at the bottom of Door Frame.

## CHAPTER 19: INSTALL THE GLASS STOPS

### WARNING

Glazer must be fully trained and qualified. Failure to do so may result in bodily injury, or property damage.

*Note: Ensure the installation area is free of debris and/or sharp objects. Failure to do so may damage the glass or contaminate the glazing process.*

### SECTION 19.1: Transom

*Note: Vinyl Bumpers vary depending upon thickness of glass. Please refer to XXXX*

1. Place each BACK PLATE of the Bracket to face the EXTERIOR side of Building.
2. Measure and mark alongside the Back Plate: across the length of the top of Header, and bottom of the Transom Horizontal.
  - a. Ensure the Back Plates line up with each other. Failure to do so, will cause the glass panel to be installed on a slant.
3. Secure each Bracket with #10-24 x .625 inch screws.

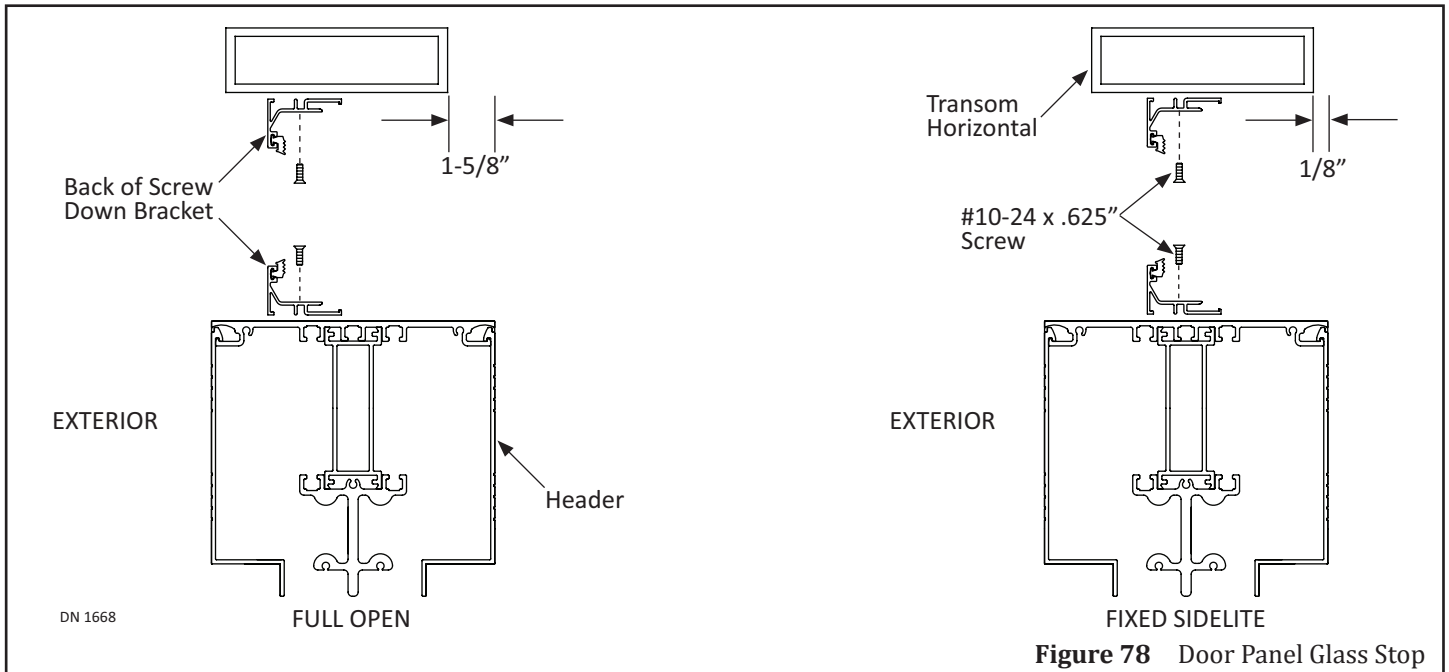

**Figure 78** Door Panel Glass Stop

4. Place Setting Blocks (not provided by NABCO) on top of the Bracket; so they will be directly underneath the Glass Panel.
  - a. Setting Blocks are used to cushion the top and bottom edges of the Glass Panel.
5. Place the Glass Panel on the Setting Blocks.
6. Secure the Glass Panel with the Glass Stop.

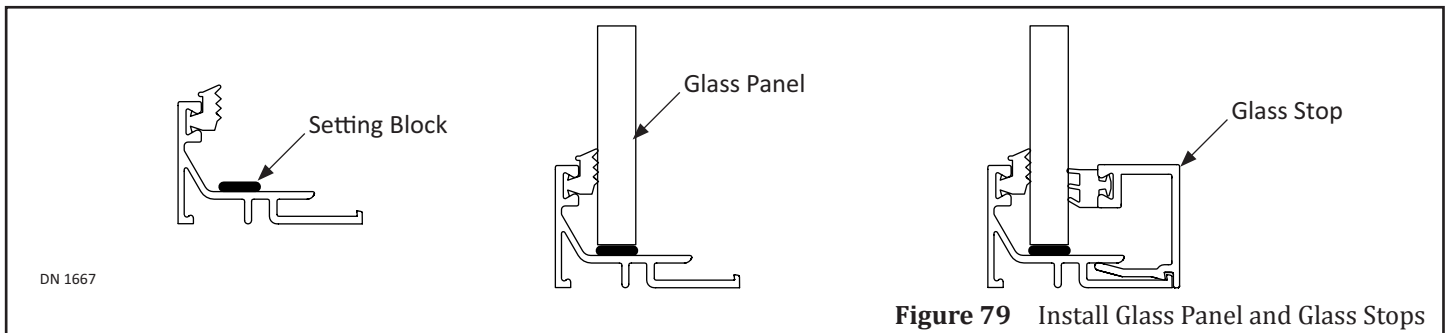

**Figure 79** Install Glass Panel and Glass Stops

**SECTION 19.2: Header**

1. Go to the side of Header that has the Removable Cover.
2. Position the Stainless Steel Hood on top of the Header so the (turned under) bottom lip is resting on the Header surface and the inside face is pressed up against the building. Ensure proper length and fit is correct.
3. Remove all protective paper to expose the Cladding tape.
4. Adhere the Stainless Steel Hood to the Header.

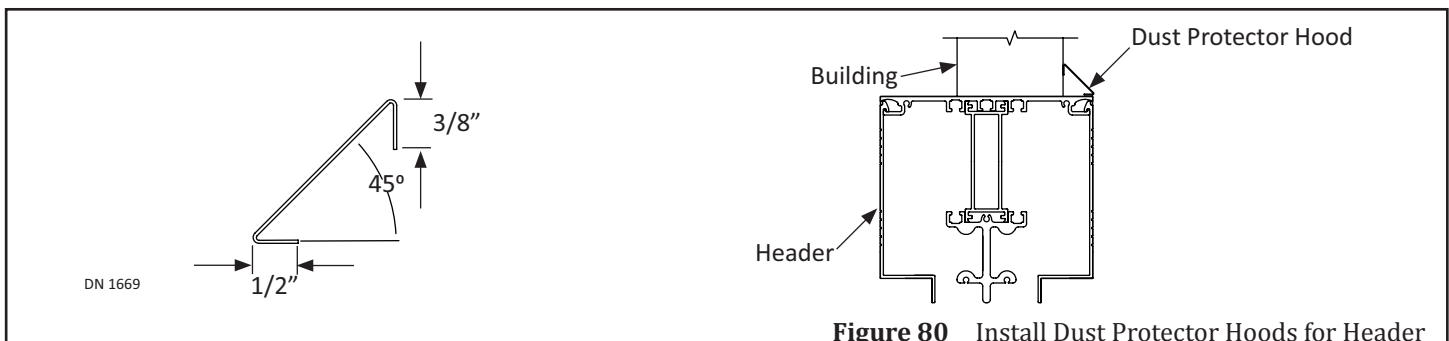

**Figure 80** Install Dust Protector Hoods for Header

## CHAPTER 20: GLAZING (HEAVY/WIDE DOORS)

In accordance with standard glazing practices, Nabco recommends Cross-Blocking for maintaining square with heavy glass or wide Door Panels (Fixed and Full Open). Cross-Blocking helps direct glass weight away from the strike edge of the door, to prevent sagging and possibly dragging on the floor or threshold.

If the Door Panel is not square and sags at the lead edge, increase the thickness of the Glazing Block (not provided by NABCO). Increasing the thickness of the Glazing Block, raises the Door Panel.

*Note: Only place Glazing Blocks in the designated marked spots.*

1. Go to the STRIKE side of door panel at the TOP.
  1. Measure (6) inches from the Bottom edge of Top Rail, towards the Pivot side of Door Panel. Mark that spot.
  2. Measure (6) inches from the Top Corner of the Strike Edge down to the bottom of the Door Panel. Mark that spot.
2. Go to the PIVOT side of door panel at the BOTTOM.
  1. Measure (6) inches from the Top edge of Bottom Rail, up to the top of Door Panel. Mark that spot.
  2. Measure (6) inches from the Center of Pivot, towards the Strike side of Door Panel. Mark that spot.
3. Place (1) Glazing Block (not provided by NABCO) between the Glass and Door Frame, at marked spots.
  - a. It may be necessary to use more than (1) Glazing Block.

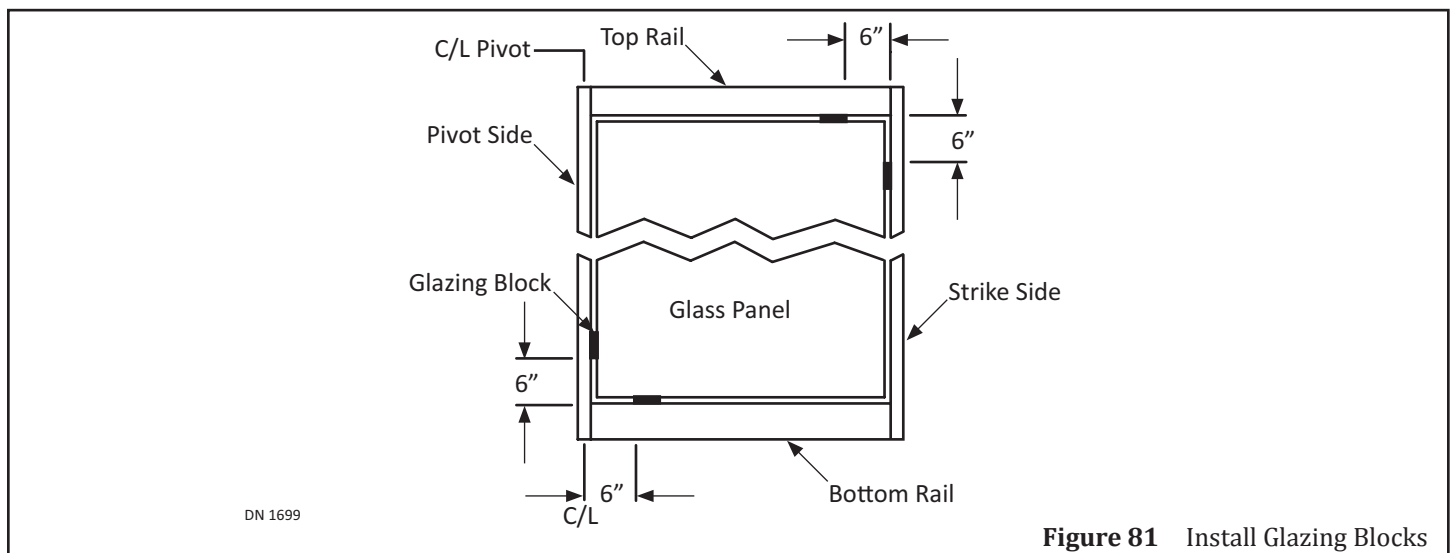

**Figure 81** Install Glazing Blocks

## CHAPTER 21: ADJUSTMENTS

### SECTION 21.1: Adjust the Hanger Rollers

1. Raise or lower the Slide door by turning the Axle clockwise with a 1/2" Open End Wrench.
  - a. The appropriate gap between the Bottom Rail and floor is between 11/16 inch to 15/16 inch; with the nominal gap being 7/8 inch.

#### CAUTION

**Do not rotate the Roller Axle counter-clockwise. Doing so will unthread the Axle from the Roller Assembly.**

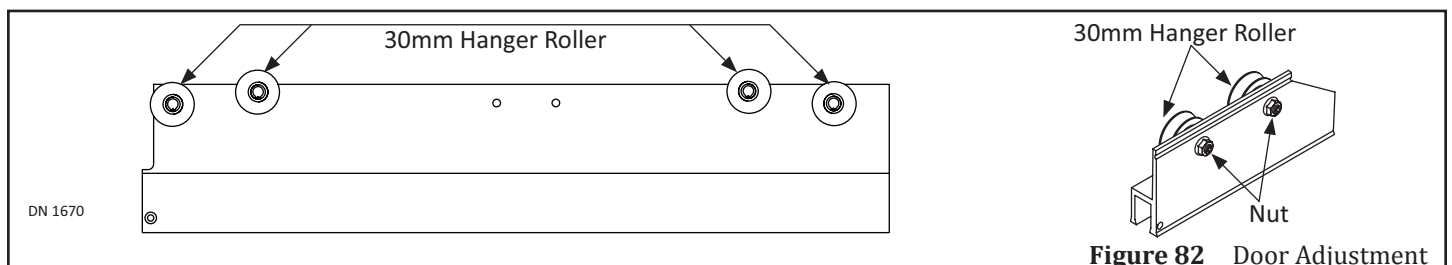

**Figure 82** Door Adjustment

2. Ensure the Leading Edge of all Slide doors and/or Jamb Tube, are parallel.

3. Ensure the Leading Edge of all Doors and Header are parallel.
4. Tighten the 5/16-18 Whizlock nuts. Do not overtighten.

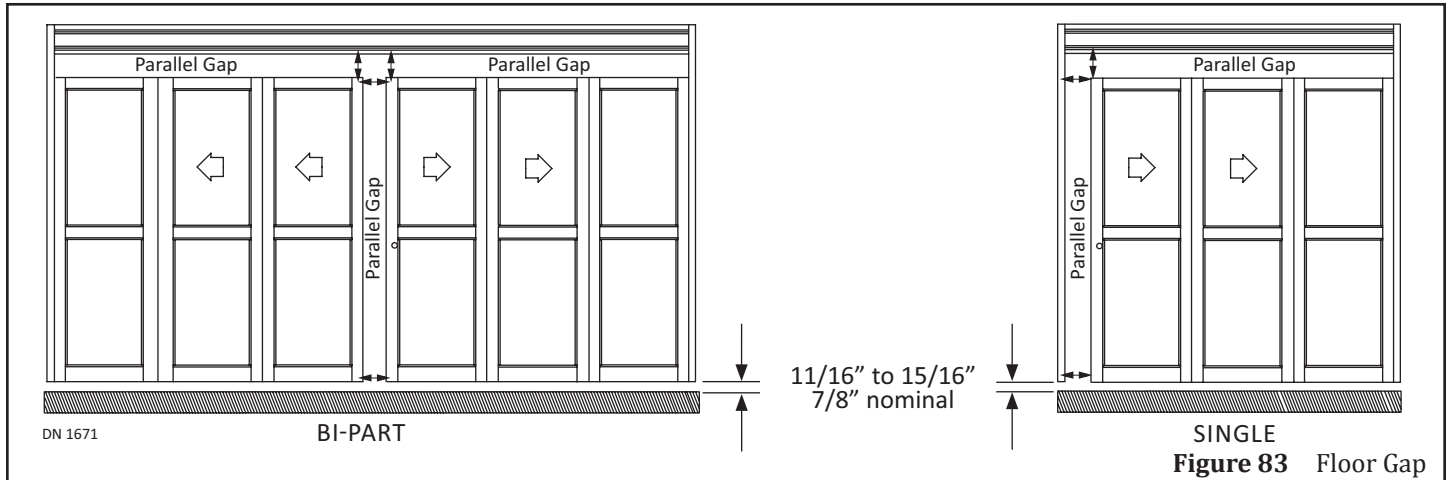

**SECTION 21.2: Adjust the Interlocks**

1. Manually close the Slide Door. Ensure the Interlocks are properly engaged. If not, adjust the Interlocks.



*Note: Adjust Interlocks so there is no contact between the Rail and the Interlock. Any contact will cause the Slide Door to bind.*

2. Obtain (1) parts bag containing (4) Shims that was taped to the Slide Door at the NABCO factory.
3. Remove the Interlock on the Sidelite, Strike Stile.
4. Place (1+) shims directly underneath the Interlock. Line up the screw holes.
5. Secure the Interlock assembly to the Sidelite Strike Stile with (2) #10-32 x 5/8 inch Phillips Head Screws.
  - a. Loosely tighten the mounting screws just enough to keep the Interlock assembly from falling out of place.

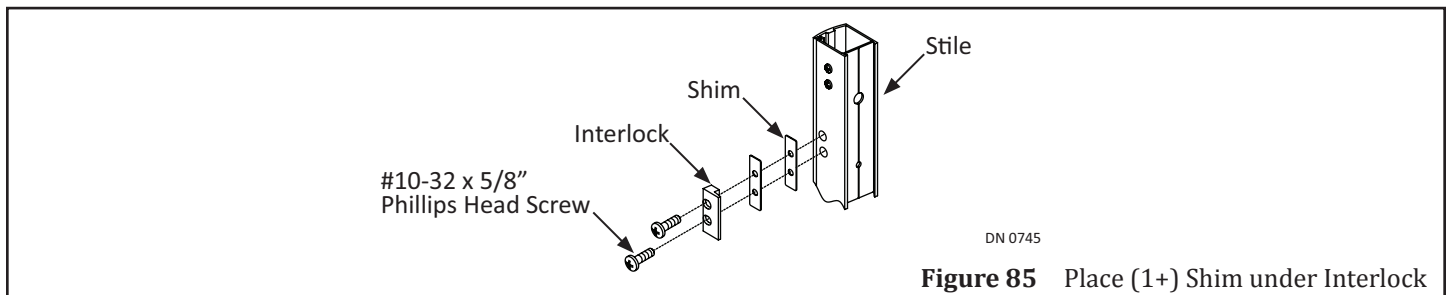

6. Go to the Interlock located on the Pivot Stile of the Slide Door. Loosen the mounting screws.
7. Manually close the Slide Door. The loosened Interlocks will automatically adjust to proper position.
8. Lock the Interlock and 1+ Shim in place by tightening the #10-32 x 5/8 inch Phillips Head Screws.

**SECTION 21.3: Adjust the Ball Plunger**

1. Breakout the Slide door. Go inside the Top Rail (closest to the Strike Stile). Remove the Panic Catch Assembly.
2. Loosen the Set screw that is located in front of the Panic Catch.

3. Go underneath the Panic Catch. Raise or lower the Ball Plunger to adjust the engagement.
  - a. The Ball Plunger must be adjusted for proper breakout resistance to meet ANSI A156.10 code and/or local code.
  - b. Use minimal engagement if Panic Hardware is used.
4. Tighten the Set screw. Secure the Panic Catch Assembly inside the Top Rail with (2) 1/4-20 x 1-1/4 inch Socket Head screws.

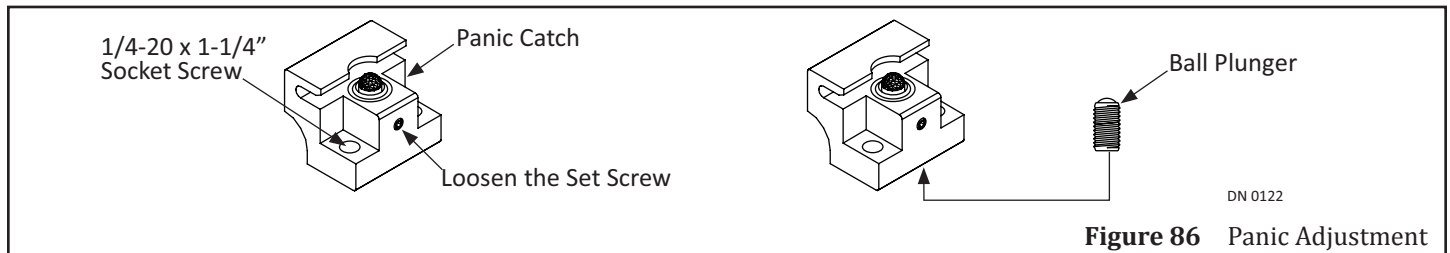

**Figure 86** Panic Adjustment

**SECTION 21.4: Adjust Preload**

1. Support the weight of Slide Door, then Breakout Slide door approximately 5 degrees (just enough to expose the Preload Adjustment Screw located on back edge of door). Do not let Slide door push up against any other Door Panel.
2. Check for door sag. The Slide door should latch without having to be manually lifted.

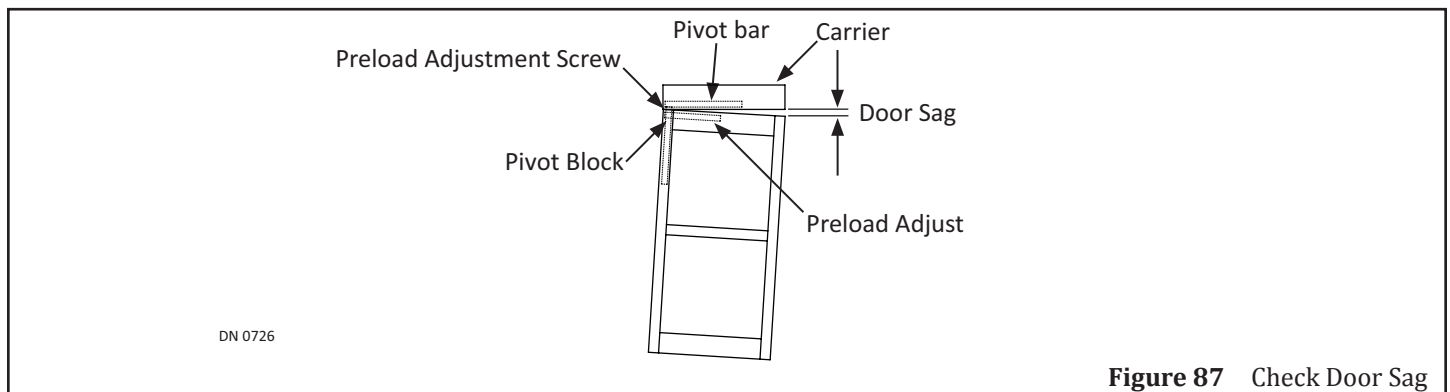

**Figure 87** Check Door Sag

3. Go to the Preload Block located inside Top Rail. Loosen (2) Locking Bolts.
4. Go to the back edge of Pivot Stile. Reduce Door sag by tightening the 5/8 inch Set Screw with an 7/32 inch Allen Wrench. Do Not allow the Adjustment Set Screw to protrude more than 7/32 inch past the end of stile.
  - a. If deemed necessary, substitute the 5/8 inch Set Screw with the optional 1/2 inch Set Screw supplied by NABCO.

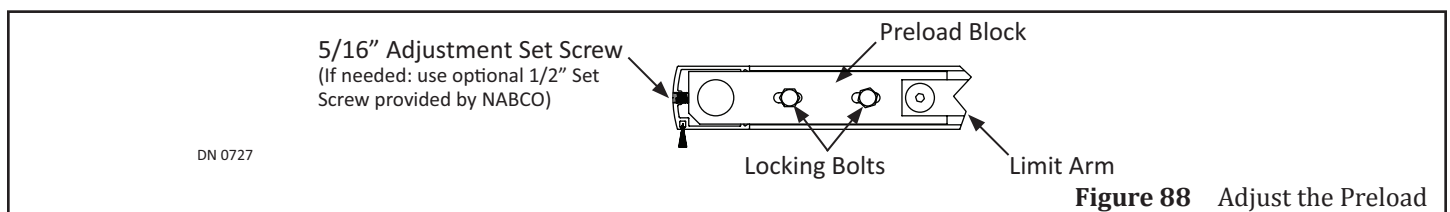

**Figure 88** Adjust the Preload

**SECTION 21.5: Correct Preload Misalignment**

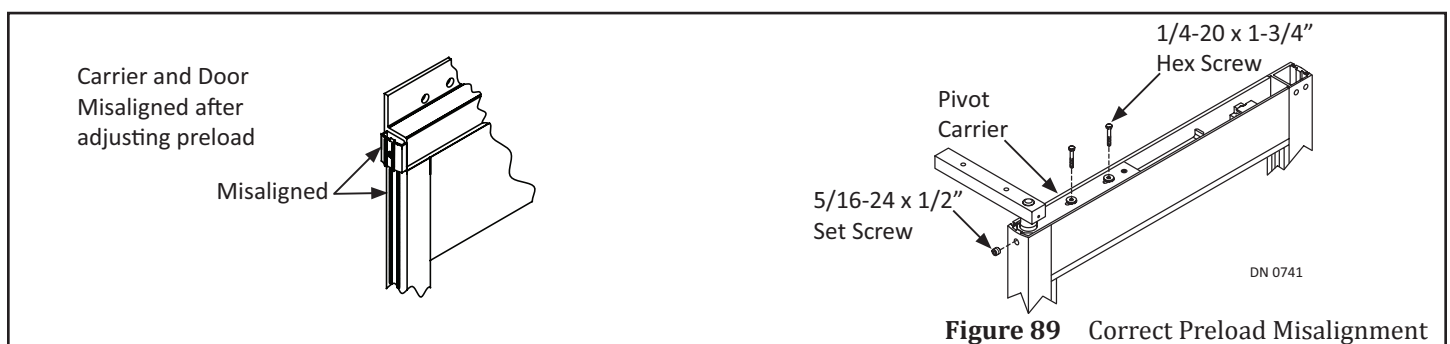

**Figure 89** Correct Preload Misalignment



1. Break Open the Slide Door. Locate the Carrier Pivot Assembly inside the Top Door Web.
2. Loosen the 5/16-24 x 1/2 Set Screw located on the Pivot Stile at the Top.
3. Loosen (2) 1/4-20 x 1.75 Hex Screws used to secure the Carrier Pivot Assembly to the Top Door Web.
4. Slide the Carrier Bar to the left or right, until the Slide Door is aligned to the Carrier. Tighten all screws.

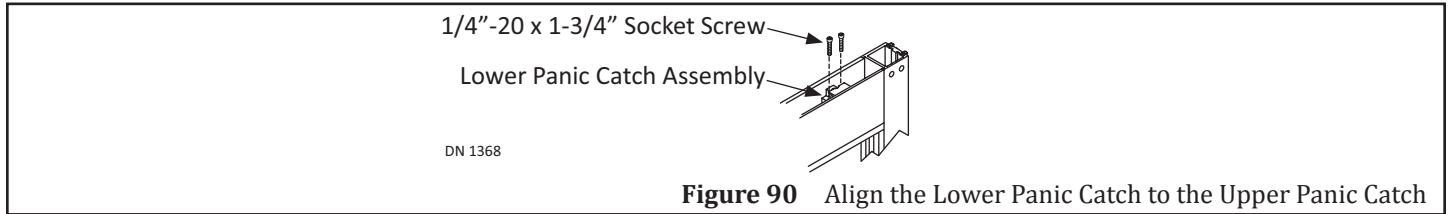

5. Verify that the Lower Panic Catch inside the Door Web is still aligned to the Upper Panic Catch inside the Carrier. If an adjustment is necessary:
  1. Go to the Lower Panic Catch. Loosen (2) 1/4-20 X 1-1/4 inch Socket Screws used to to secure the Lower Panic Catch to the Door Web.
  2. Slide the Lower Panic Catch to the right or to the left until it is aligned to the Upper Panic Catch. Tighten Socket Screws.

**SECTION 21.6: Adjust the Breakout Magnet**

1. The Magnet is secured to the Limit Arm Bracket that can slide to the Left and Right. Slide the Breakout Magnet to the Left or to the Right until it is aligned with the Magnetic Reed Switch.
  - a. The Magnetic Reed Switch is a 3/8 inch diameter black circle located on the Bottom Lip of Header.

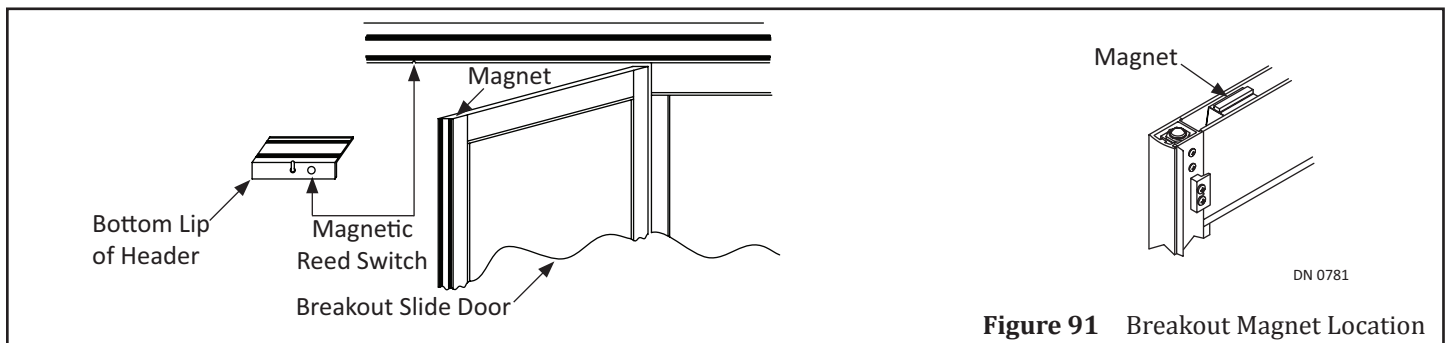

**SECTION 21.7: Adjust the Nose Caster**

*Note: For Units 54 Inches Wide (or greater) and/or over 200 Pounds.*

1. Go to the Bottom Rail. Remove (1) End Cap.
2. Break Open the Slide door. Locate the Nose Caster that was pre-installed within the Strike Stile.

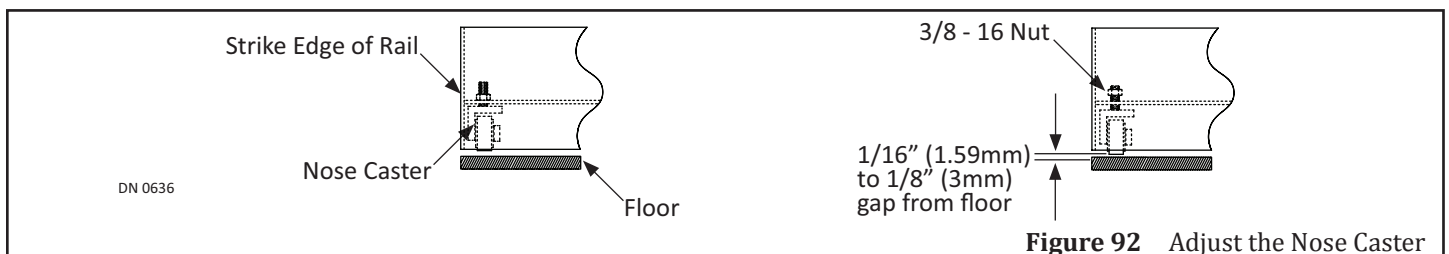

3. Loosen the #8-32 Set Screw. Position the Wheel so it is perpendicular to the Bottom Rail. Retighten the #8-32 Set Screw.
4. Fully close the Slide door. Ensure the Nose Caster does not hit or scrape the floor. Reinstall the End Cap.

## SECTION 21.8: Belt Adjustment

### WARNING

Do Not adjust tension on Timing Belt unless Failure occurs. Such as: the belt breaks, or the belt is jumping teeth on the Pulley.

### CAUTION

Adjust the Timing Belt before adjusting the Lead Door Drive Belt. Adjust the Lead Door Drive Belt before adjusting the Trail Door Drive Belt. Failure to do so, will cause Belts to break.

### CAUTION

Tension the Timing Belt by Hand ONLY. Failure to do so will cause the Timing Belt to break.

### 21.8.1 Tighten the Timing Belt

1. Remove Header Cover(s) from both sides of Door.
2. Locate the Speed Reducer Sub-Assembly that controls the Trail Door.
  - a. The Speed Reducer Sub-Assembly for the Trail Door is always closest to the End Cap.
3. Go to the Mounting Plate. Loosen (4) 5/16x18 Hex Nuts, and 5/16" Lock Washers from (4) 5/16-18x 3/4 Bolts so the Mounting Plate can slide within the Header Channels.
4. With (1) hand, slide the Speed Reducer, Sub-Assembly toward the End Cap. This will tension the Timing Belt.
5. Tighten the (4) Bolts.

### CAUTION

Tension the Timing Belt by Hand ONLY. Do Not tighten the Bolt/Nut located on the Speed Reducer. Over-tensioning so will cause the Belt to break.

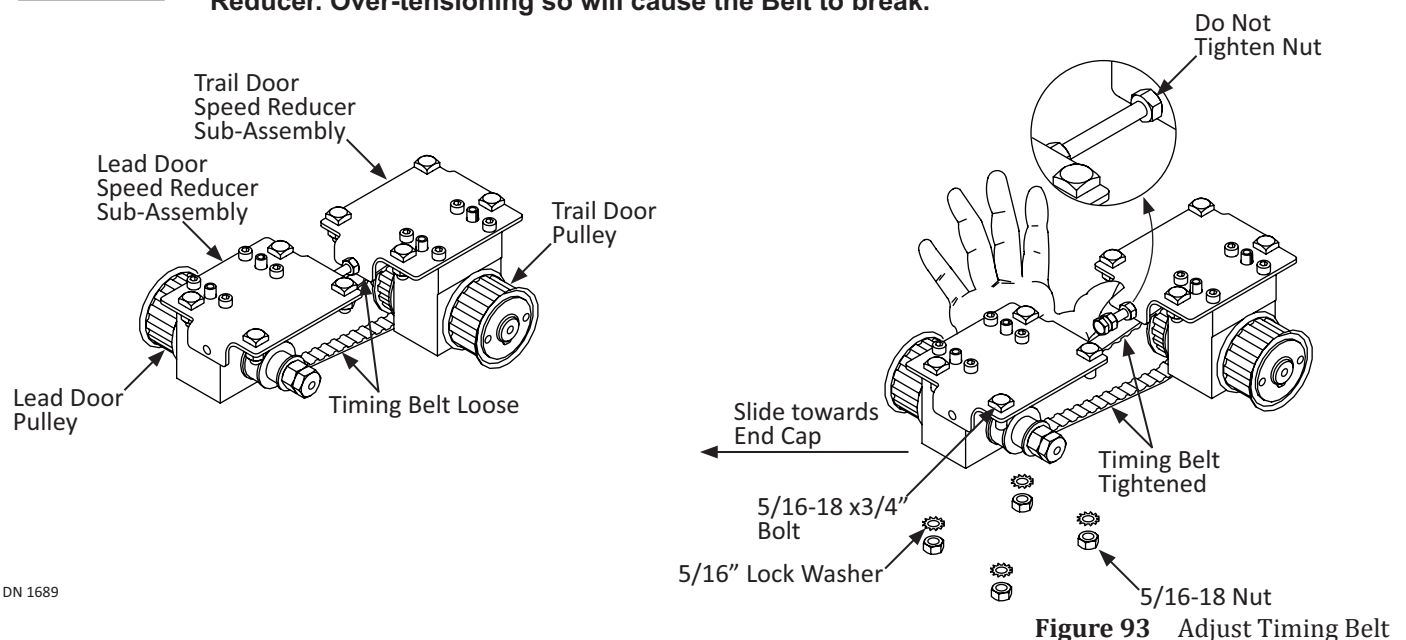

### 21.8.2 Tighten the Lead Door Drive Belt

1. Go to the DS-150 Operator.
2. Go to the Mounting Plate. Loosen (4) 5/16x18 Hex Nuts, and 5/16" Lock Washers from (4) 5/16-18x 3/4 Bolts so the Mounting Plate can slide within the Header Channels.
3. Go to the Belt Tension Bracket Assembly.
4. Loosen the 3/8-16" Hex Jam Nut from the 3/8-16 x 2-1/8 inch long Bolt.
5. Rotate the 3/8-16 x 2-1/8 inch long Bolt, clockwise. This will tension the Drive Belt.
6. Tighten the Jam Nut.
7. Tighten the (4) 5/16-18 Hex Nuts.

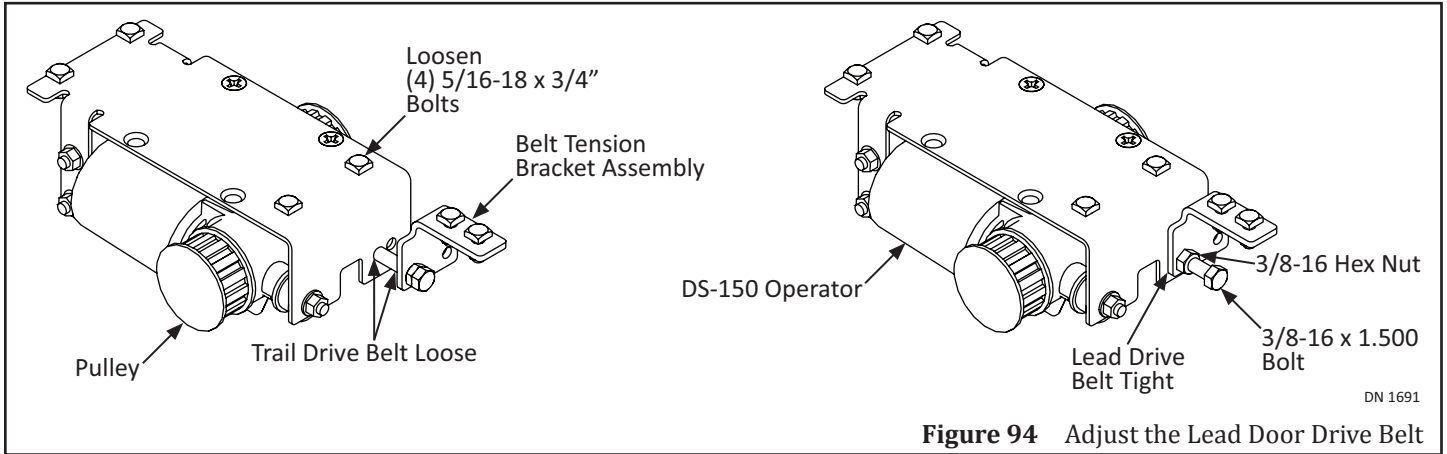

**Figure 94** Adjust the Lead Door Drive Belt

### 21.8.3 Tighten the Trail Door Drive Belt

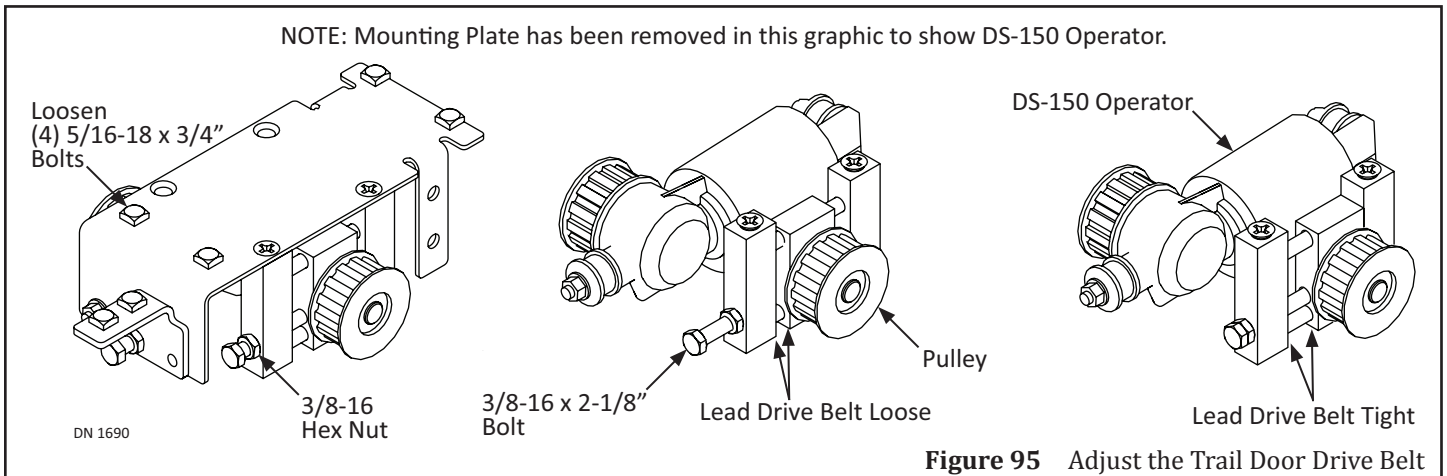
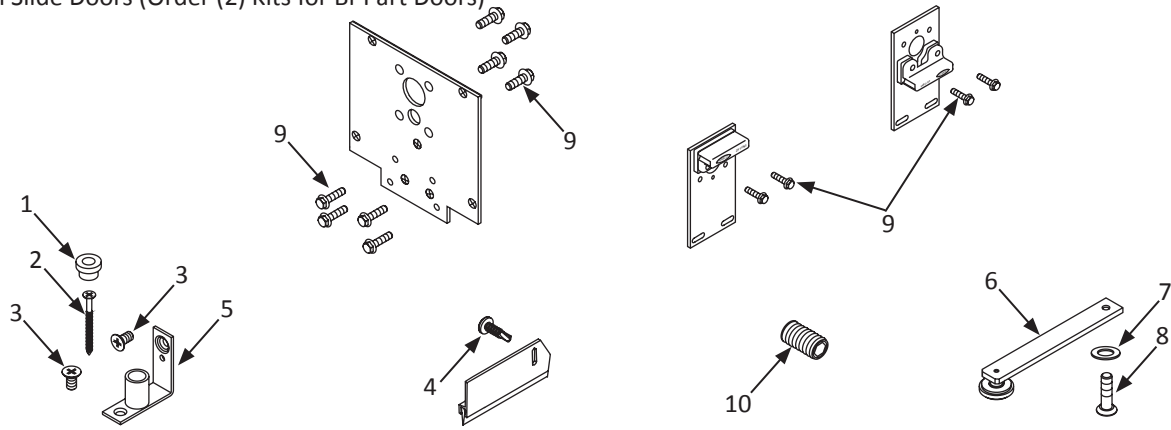

**Figure 95** Adjust the Trail Door Drive Belt

1. Go to the opposite side of the DS-150 Operator. Locate the Pulley.
  - a. The Pulley on the opposite side of the DS-150, controls the Trail Door Drive Belt.
2. Loosen the 3/8-16" Hex Jamb Nut from the 3/8-16 x 2-1/8 inch long Bolt.
3. Rotate the 3/8-16 x 2-1/8 inch long Bolt, clockwise. This will tension the Drive Belt.
4. Tighten the Jam Nut.

### SERVICE PARTS: NON HANDED KIT P/N A-00408

Full Open Slide Doors (Order (2) Kits for Bi-Part Doors)



DN 1672

#### Full Open Sidelite Parts Kit: P/N A-00408

Item	Part	Note	Description	QTY	Used To
1	M-00606		BUSHING, BOTTOM PIVOT, SWING PANEL	1	Protect inside of Barrel from dust/dirt
2	T-00008		FHSMS,1/4x2.750L.,PHIL,TAPCON,BLUE	1	Secure Bottom Pivot (M-00611) to floor
3	T-00007		FHMS,1/4-20x0.500L.,PHIL,UNDR CUT,F-PT,ZN	1	Secure Bottom Pivot (M-00611) to floor.
4	T-00222	Zinc	PHSMS,6x0.500L.,PHIL,TEKS,ZINC	12	Secure Bottom Pivot (M-00611) to Pivot Jamb Tube.
	T-00260	Black Zinc	PHSMS,6x0.500L. PHIL,TEKS BLK ZN		Secure Brush Holder to Door Panels.
5	M-00611		FLOOR PIVOT BRACKET	1	Allow Sidelite to swing Open and Closed
6	A-00060	Narrow	LIMIT ARM,SWING PANEL,ASM.NRW.STILE	1	Allow Sidelite to swing Open and Closed
	A-00406	Medium	LIMIT ARM, SWING PANEL, MED STILE	1	
7	T-00069		WASHER,.255 ID,.900 OD,.125 THK,NYLON	1	Keep Screw from digging into face of Limit Arm
8	T-00083		FHMS,1/4-20x1.000L.,PHIL,UCUT,VIBRATITE	1	Secure Limit Arm to bottom of Header
9	T-00140		HHCS,1/4-20x1.000L.,WHIZLOCK,ZINC	4	Secure Belt Bracket to Carrier on top of Slide Door
				16	Secure Header to Jamb Tubes
10	T-00261		SHSS,5/16-24x0.500L.,CUP PT.	1	Adjust PreLoad (top of Strike Stile on Slide Door)

### SERVICE PARTS: LH KIT P/N A-00619; RH KIT P/N A-00618

Fixed Sidelite Slide Doors

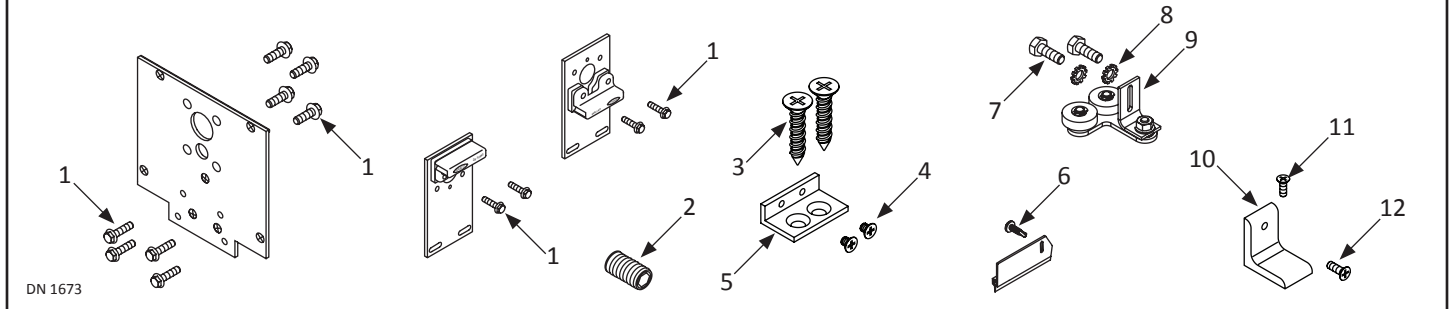

**Fixed Sidelite Parts Kit: LH P/N A-00619 and RH P/N Kit: A-00618**

Item	Part	Note	Description	QTY	Used To
1	T-00140		HHCS,1/4-20x1.000L.,WHIZLOCK,ZINC	4	Secure Belt Bracket to Carrier on top of Slide Door
				16	Secure Header to Jamb Tubes
2	T-00261		SHSS,5/16-24x0.500L.,CUP PT.	1	Adjust PreLoad on Slide Door (at top of Strike Stile)
3	T-00062	Zinc	FHSMS,1/4x1.250L.,PHIL,TAPCON,BLUE	1	Secure Floor Bracket (M-01368) to Floor
4	T-00004	Zinc	FHMS,10-24x0.250L.,PHIL,UNDERCUT,ZINC	2	Secure Floor Bracket (M-01368) to Strike Stile
	T-00357	Blk Zinc	FHMS:10-24x0.250L.:PHIL:UNDERCUT:BLK ZN	2	
5	M-01368		FLOOR BRACKET, TELESCOPIC FS	1	Secure Fixed Sidelite to Floor
6	T-00222	Zinc	PHSMS,6x0.500L.,PHIL,TEKS,ZINC	8	Secure Brush Holder to Door Panel(s)
	T-00260	Blk Zinc	PHSMS,6x0.500L. PHIL,TEKS BLK ZN		
7	T-00064		HHCS,1/4-20x0.750L.,ZINC	4	Secure Bracket portion of the BTM Guide to Pivot Stile on Slide Door
8	T-00087		WASHER, LOCK, EXT, 1/4 ID, ZINC	4	Keep Screw (T-00064) in place
9	A-00181	RH	BTM GUIDE DOUBLE ROLLER ASM, RH	2	Allow Slide Door to Open/Close.
	A-00183	LH	BTM GUIDE DOUBLE ROLLER ASM, LH		
10	M-01472		BRACKET:COVER:FS TELESCOPIC	1	Secure Fixed Sidelite to Header Cover
11	T-00024		FHMS,8-32x0.625L.,PHIL,F-POINT,ZINC	1	Secure Bracket (M-01472) to Header Cover
12	T-00015	Zinc	FHMS,1/4-20x0.750L.,PHIL,ZINC	1	Secure Bracket to Fixed Sidelite
	T-00017	Blk Zinc	FHMS,1/4-20x0.750L.,PHIL,BLK ZN		

### SERVICE PARTS: HEADER

\* Sold in Parts Bag P/N A-00618 RH  
P/N A-00619 LH  
P/N A-00408

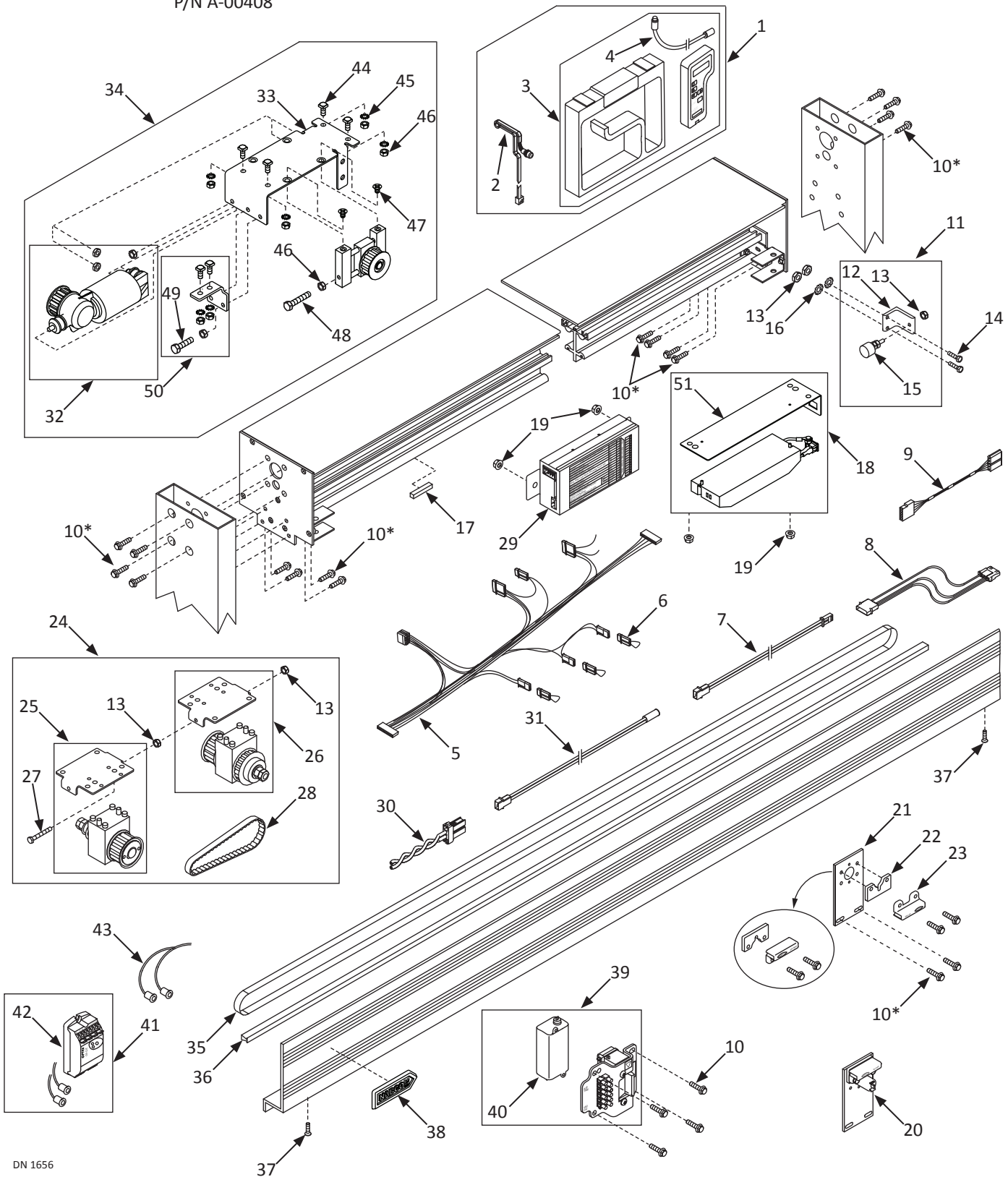

DN 1656

Header			
Item	Part	Finish/Sizes/Notes	Description
1	A-00711		"KIT,HANDY TERMINAL"
2	M-01517		"HARNESS,HANDY TERMINAL"
3	V-00356		HANDY TERMINAL
4	M-01410		CABLE,HANDY TERMINAL
5	M-00413		HARNESS,U30,CONTROL
6	A-00385		BREAKOUT JUMPER
7	M-01073	90 inches	HARNESS,BREAK OUT SWITCH,90IN EXTENTION
	M-01136	35 inches	HARNESS,BREAK OUT SWITCH,35IN EXTENSION
8	M-01156	48 inches	ACCUSENSOR EXT HARNESS 48" INT.
	M-01168	24 inches	HARNESS,ACUSENSOR EXT,24 INT
9	A-00967	36 inches	HARNESS;EXTENSION;ROCKER SWITCH;36IN.
	A-00968	72 inches	HARNESS;EXTENSION;ROCKER SWITCH;72IN.
	A-00969	80 inches/not 180 inches	HARNESS;EXTENSION;ROCKER SWITCH;180IN.
10	T-00140		HHCS,1/4-20x1.000L.,WHIZLOCK,ZINC
11	A-00299		DOOR STOP,TELE ASM
12	M-00502		BRACKET, IDLER/STOP
13	T-00002		NUT,HEX,1/4-20,ZINC
14	T-00139		HHCS,1/4-20x1.000L.,GR5,ZINC
15	A-00087		BUMPER,DOOR STOP
16	T-00087		WASHER, LOCK, EXT, 1/4 ID, ZINC
17	M-00281		FOAM WEATHERSTRIPPING ADHESIVE BACKED
18	A-00717		POWER SUPPLY,27 VDC,100 WATT
19	T-00025		NUT,WHIZLOCK,3/8-16,ZINC
20	A-00267		BELT CLIP,TOP W-LATCHBOLT,1175T
21	M-00913		BRKT, TELE BELT CLIP
22	M-00392		SPACER,BELT CLIP
23	M-00391		BELT,CLIP
24	A-00272	RH	SPEED REDUCER, 2,1, RH ASM
	A-00275	LH	SPEED REDUCER, 2,1, LH ASM
25	A-00274		SPEED REDUCER, 2,1, DRIVEN SUB-ASM
26	A-00271		SPEED REDUCER, 2,1, DRIVER SUB-ASM
27	T-00146		HHCS,1/4-20x2.000L.,FULL THREAD,ZINC
28	T-00038		BELT, 173L050 TIMING
29	V-00020		CONTROLLER, U30
30	M-00412		HARNESS,U30,POWER
31	A-00758	Full Open Sidelite only	SWITCHBREAKOUT
32	M-00395		OPERATOR,DS150
33	M-00943		BRKT, DS-150 MTR SUPPORT
34	A-00280	RH	DRIVE, RH, PARTS KIT ASM
	A-00284	LH	DRIVE, LH, PARTS KIT ASM
35	M-01491		BELT: .500 PITCH: "H" PROFILE
36	M-00688		PILE WEATHERING .45 TALL W/ ADHESIVE

Header			
Item	Part	Finish/Sizes/Notes	Description
37	T-00024	Zinc	FHMS,8-32x0.625L.,PHIL,F-POINT,ZINC
	T-00179	Black Zinc	"FHMS,8-32x0.625L.,PHIL,BK.ZC.TYPE F"
38	C-00067		"NAMEPLATE, ADHESIVE BACKED"
39	A-00293	Fail Secure	ELECTRIC STRIKE, TELE FAIL SECURE ASM
	A-00294	Fail Safe	ELECTRIC STRIKE,TELE FAIL SAFE, ASM
40	V-00022		POWER SUPPLY, 24VDC, 0.5A
41	A-00709		HOLDING BEAM SYSTEM
42	A-00129		AMPLIFIER, PHOTOEYE, OPTEX ASSY
43	V-00073		HOLDING BEAM,PHOTO ELECTRIC,W/ EXT CABLE
44	T-00143		SQHCS,5/16-18x0.750L.
45	T-00145		WASHER, LOCK, EXT, 5/16 ID, ZINC
46	T-00144		NUT,HEX,5/16-18,ZINC
47	T-00162		FHMS,5/16-18x0.500L.,PHIL,UNDERCUT,ZINC
48	T-00163		HHCS,3/8-16x2.250L.,FULL THREAD,ZINC
49	T-00161		HHCS,3/8-16x1.500L.,FULL THREAD,ZINC
50	A-00278		BRKT, BELT TENSION ASM
51	M-01624		"BRACKET,POWER SUPPLY,1175"



### SERVICE PARTS: LEFT HAND FIXED SIDELITE

Viewed from Break Out Side

\* Sold in Parts Bag P/N A-00618 RH; A-00619 LH

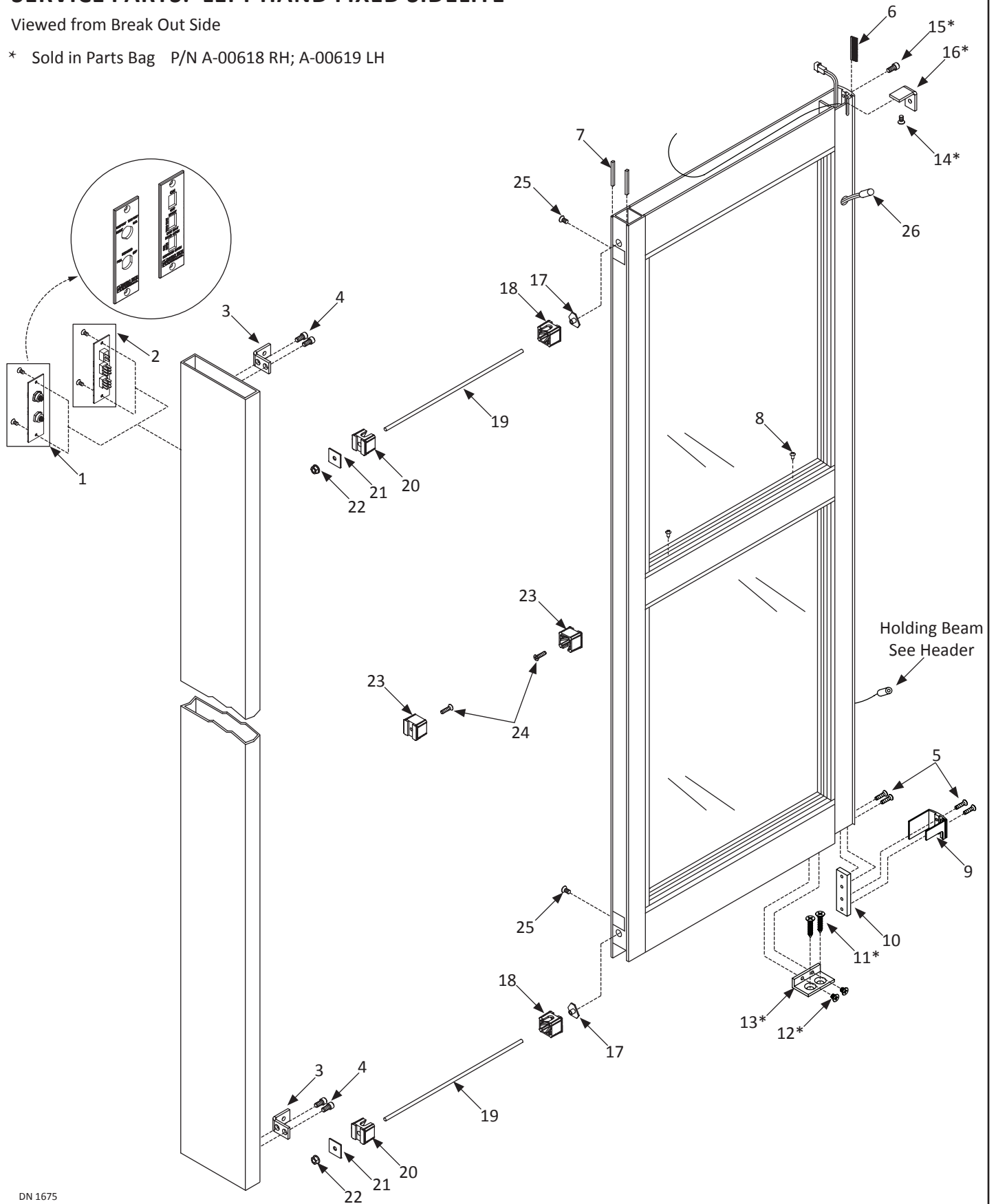

### SERVICE PARTS: RIGHT HAND FIXED SIDELITE

Viewed from Break Out Side

\* Sold in Parts Bag P/N A-00618 RH; A-00619 LH

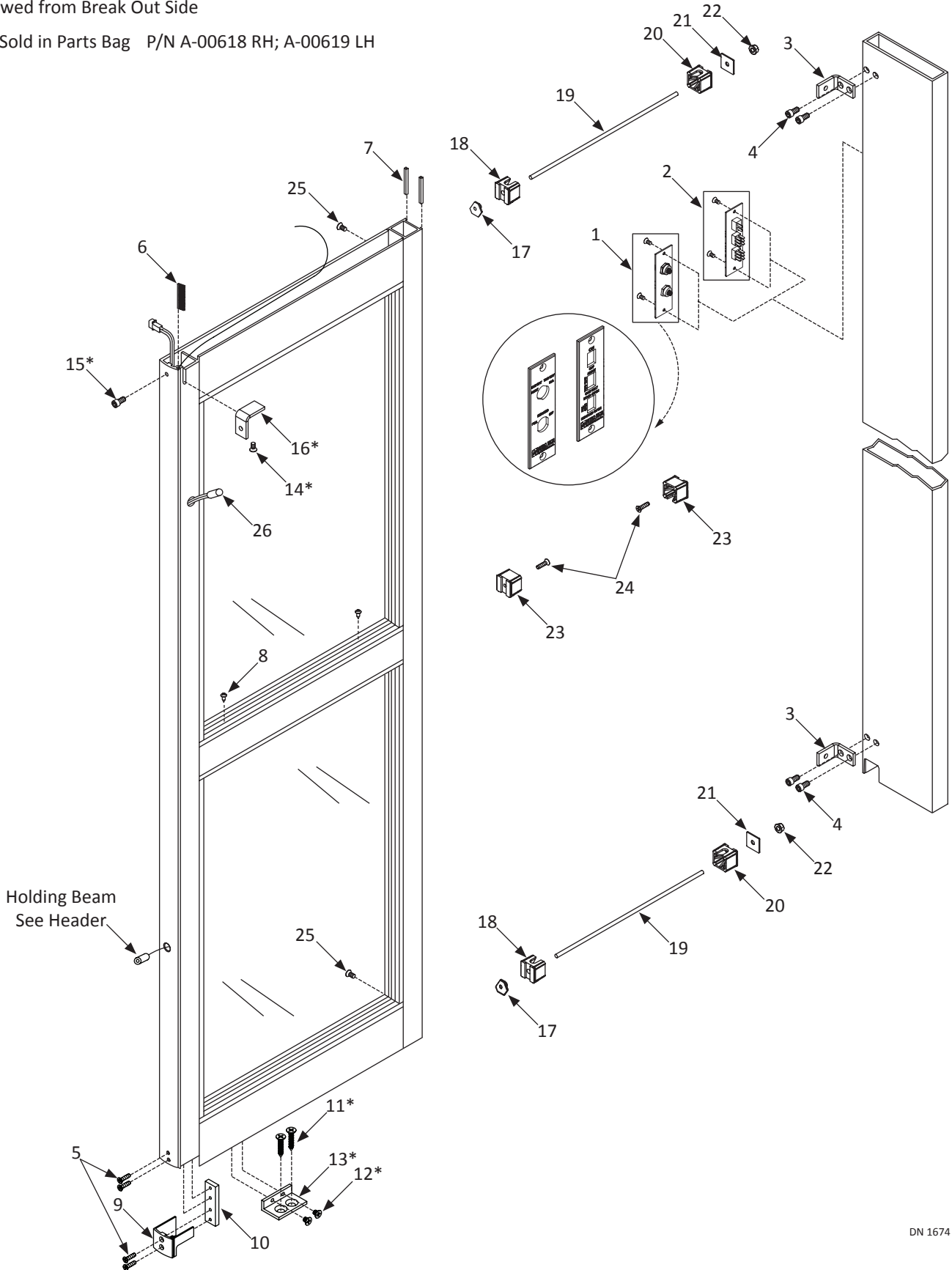

DN 1674

Fixed Sidelite			
Item	Part	Finish/Sizes/Notes	Description
1	M-01144	NABCO	SWITCH, KEY - NABCO
	M-01145	Porta Service	SWITCH, KEY - PORTA SERVICE
2	M-00428	NABCO	SWITCH MODULE,3 ROCKER,NABCO
	M-00429	Porta Service	SWITCH MODULE,3 ROCKER,PORTA
3	M-00706		BRACKET,MOUNTING ,FIXED SIDELITE
4	T-00053		SHCS,1/4-20x0.500L.,ZINC
5	T-00176	Zinc	FHMS,10-32x0.500L.,PHIL,UCUT,23-PT,ZINC
	T-00183	Black Zinc	FHMS,10-32x0.500L.,PHIL,UCUT,23-PT,BLKZN
6	A-00951		"BRUSH, NYLON, .56 LX1.875L."
7	M-00281	Include Length needed when ordering	FOAM WEATHERSTRIPPING ADHESIVE BACKED
8	T-00098		PHSMS,10x0.563L.,PHIL,TYPE A
9	A-60010	RH/Clear	"COVER,BTM,TELE,FS,RH,204"
	A-60009	LH/Dark Bronze	"COVER,BTM,TELE,FS,LH,204"
	A-70010	RH/Clear	"COVER,BTM,TELE,FS,RH,313"
	A-70009	LH/Dark Bronze	"COVER,BTM,TELE,FS,LH,313"
10	M-01229		BRACKET,ROLLER COVER,BACKING
11	T-00062		FHSMS,1/4x1.250L.,PHIL,TAPCON,BLUE
12	T-00004		FHMS,10-24x0.250L.,PHIL,UNDERCUT,ZINC
13	M-01368		FLOOR BRACKET, TELESCOPIC FS
14	T-00024		FHMS,8-32x0.625L.,PHIL,F-POINT,ZINC
15	T-00015	Zinc	FHMS,1/4-20x0.750L.,PHIL,ZINC
	T-00017	Black Zinc	FHMS,1/4-20x0.750L.,PHIL,BLK ZN
16	M-01472		BRACKET:COVER:FS TELESCOPIC
17	M-00416		T-NUT, 3/8"-16, TIE ROD
18	M-00460		CLIP,MUNTIN,.500 HOLE
19	M-00272		3/8-16 THREADED ROD
20	M-00461		CLIP,MUNTIN,.386 HOLE
21	M-00422		PLATE,TIE ROD
22	T-00025		NUT,WHIZLOCK,3/8-16,ZINC
23	M-00462		CLIP,MUNTIN,.261 HOLE
24	T-00061	Zinc	FHMS,1/4-20x1.000L.,PHIL,TRI-LOBE,ZINC
25	T-00055	Zinc	FHMS,1/4-20x0.500L.,PHIL,ZINC
	T-00057	Black Zinc	FHMS,1/4-20x0.500L.,PHIL,BLK ZN
26	A-00387	White/Installed inside Strike Stile/See Header for Extension Harnesses	BREAK OUT SWITCH, WIDE GAP - F/S

### SERVICE PARTS: LEFT HAND TRAIL DOOR FOR FIXED SIDELITE

Viewed from Break Out Side

\* Sold in Parts Bag P/N A-00619 LH

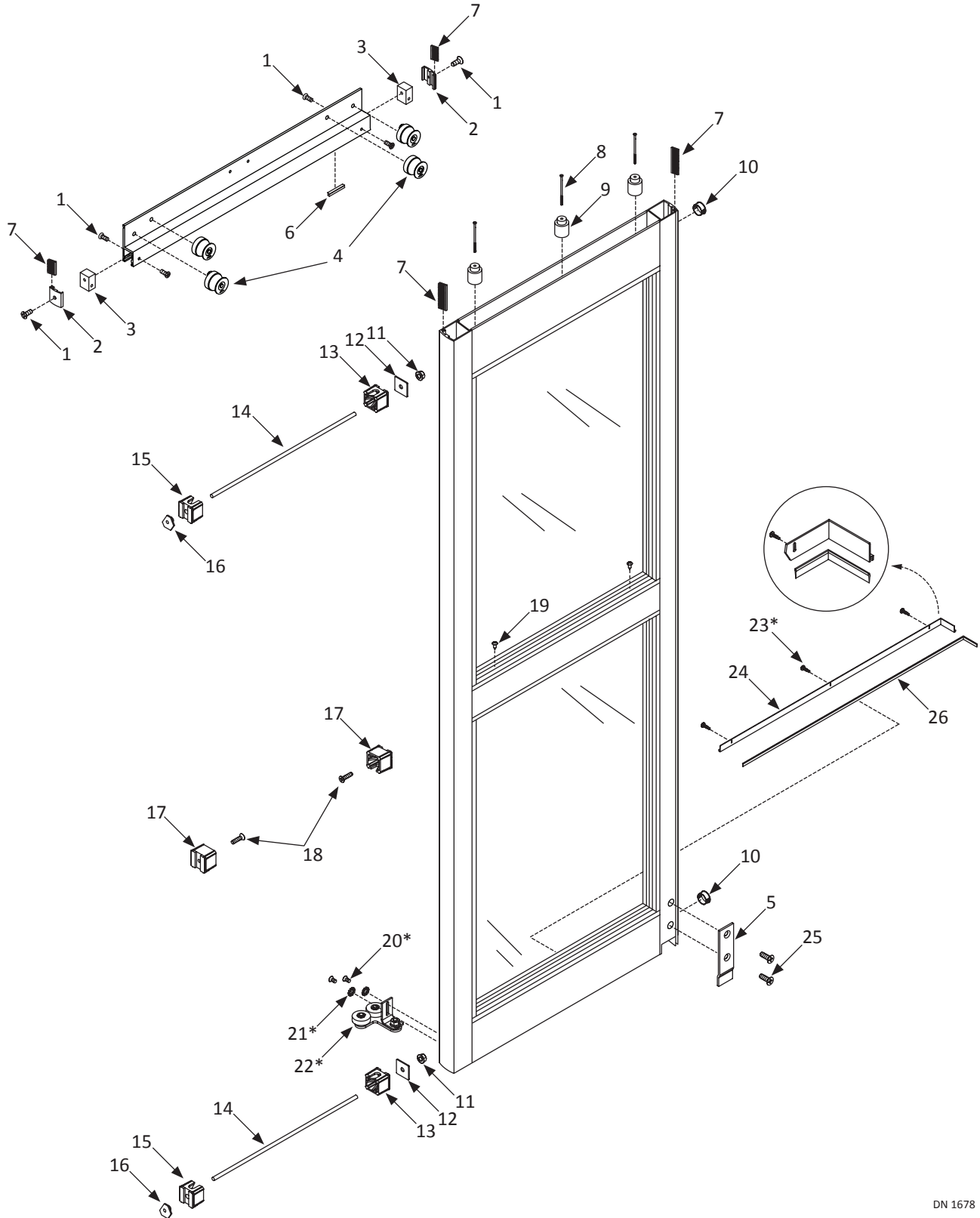

DN 1678

# SERVICE PARTS: RIGHT HAND TRAIL DOOR FOR FIXED SIDELITE

Viewed from Break Out Side

\* Sold in Parts Bag P/N A-00618 RH

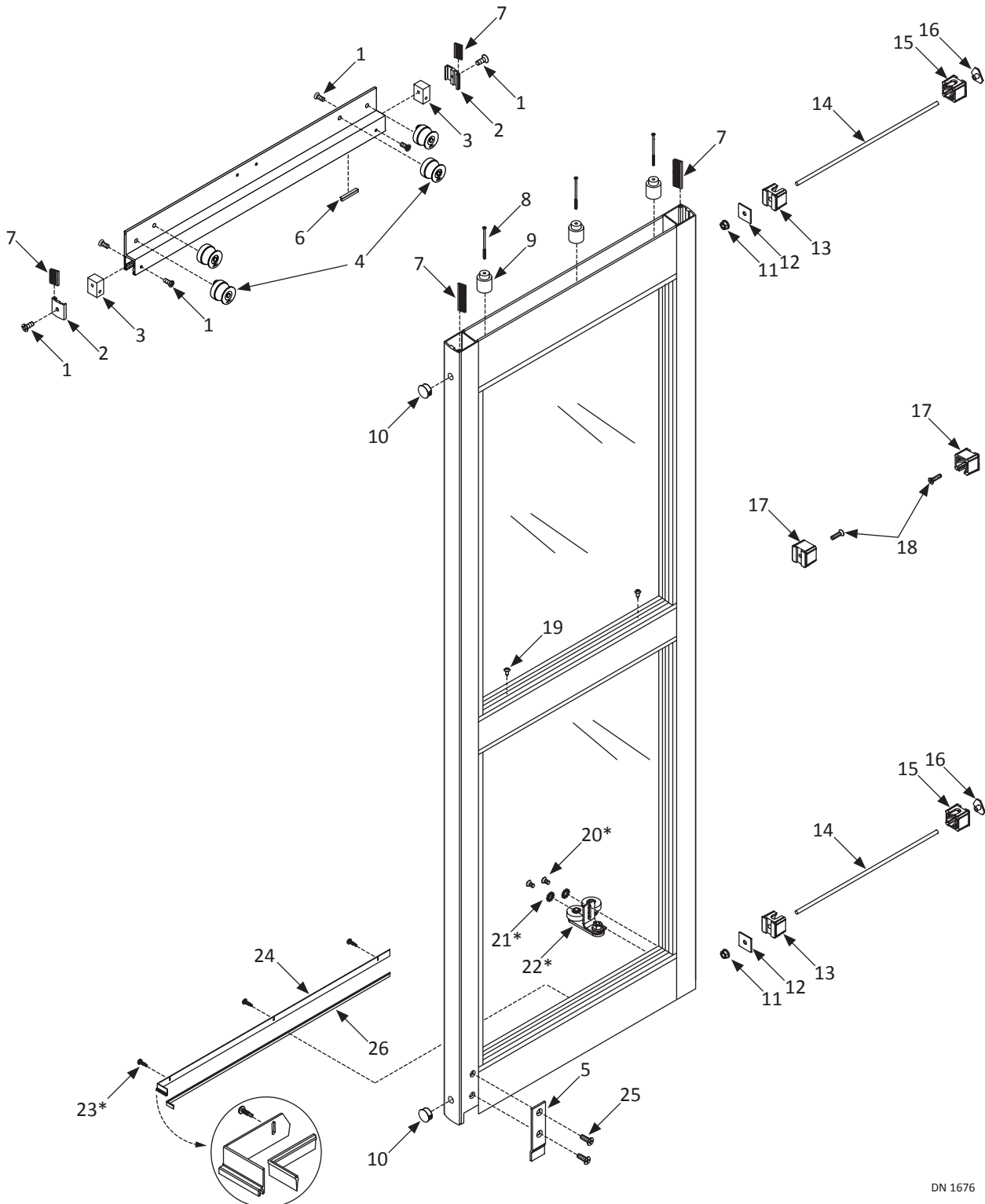

DN 1676

Fixed Sidelite Trail Door			
Item	Part	Finish/Sizes/Notes	Description
1	T-00176	Zinc	FHMS,10-32x0.500L.,PHIL,UCUT,23-PT,ZINC
	T-00183	Black Zinc	FHMS,10-32x0.500L.,PHIL,UCUT,23-PT,BLKZN
2	M-01222	Clear	END CAP,BOTH ENDS,TRAIL DOOR,204
	M-71222	Dark Bronze	END CAP,BOTH ENDS,TRAIL DOOR,313
3	M-01286		MOUNT BLOCK, END CAP - TRAIL DOOR
4	A-00961		"ROLLER HANGER,30mm;TELE & ICU"
5	M-00717	RH	FLOOR BRKT, RHFS
	M-00710	LH	BRACKET,FLOOR, LHFS
6	M-00690		WEATHER, PILE .2
7	M-00695		BRUSH, NYLON, .56 L
8	T-00125		"FHMS,1/4-20x4.250L.,PHIL,ZINC"
9	M-01095		ADAPTER,BLOCK,NO PANIC,DOOR SLIDER
10	T-00085		PLUG, DOME, .813 DIAMETER
11	T-00025		NUT,WHIZLOCK,3/8-16,ZINC
12	M-00422		PLATE,TIE ROD
13	M-00461		CLIP,MUNTIN,.386 HOLE
14	M-00272		3/8-16 THREADED ROD
15	M-00460		CLIP,MUNTIN,.500 HOLE
16	M-00416		T-NUT, 3/8"-16, TIE ROD
17	M-00462		CLIP,MUNTIN,.261 HOLE
18	T-00061		FHMS,1/4-20x1.000L.,PHIL,TRI-LOBE,ZINC
19	T-00098		PHSMS,10x0.563L.,PHIL,TYPE A
20	T-00064		HHCS,1/4-20x0.750L.,ZINC
21	T-00087		WASHER, LOCK, EXT, 1/4 ID, ZINC
22	A-00181	RH	BTM GUIDE DOUBLE ROLLER ASM, RH
	A-00183	LH	BTM GUIDE DOUBLE ROLLER ASM, LH
23	T-00222	Zinc	PHSMS,6x0.500L.,PHIL,TEKS,ZINC
	T-00260	Black Zinc	PHSMS,6x0.500L. PHIL,TEKS BLK ZN
24	14-10659-01	RH/Clear	WEATHERING HOLDER
	14-10659-02	RH/Dark Bronze	WEATHERING HOLDER
	14-10660-01	LH/Clear	WEATHERING HOLDER
	14-10660-02	LH/Dark Bronze	WEATHERING HOLDER
25	T-00313		FHSMS - SLOTTED, #14 X 1 1/12" LG
26	M-00274	Stepped	BRUSH, NYLON, 1" STEPPED

### SERVICE PARTS: LEFT HAND LEAD DOOR FOR FIXED SIDELITE

Viewed from Break Out Side

\* Sold in Parts Bag P/N A-00619 LH

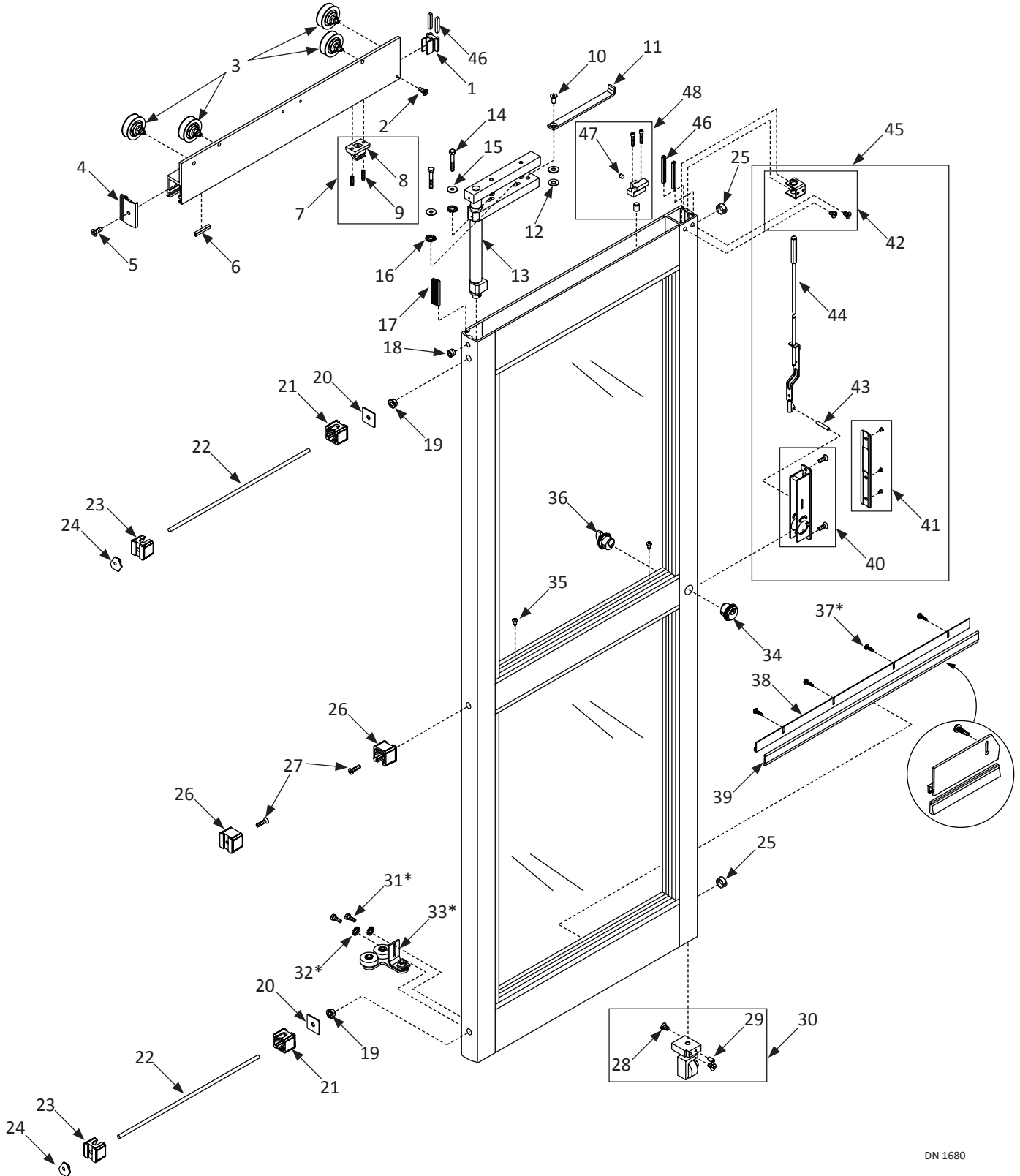

DN 1680

### SERVICE PARTS: RIGHT HAND LEAD DOOR FOR FIXED SIDELITE

Viewed from Break Out Side

\* Sold in Parts Bag P/N A-00618 RH

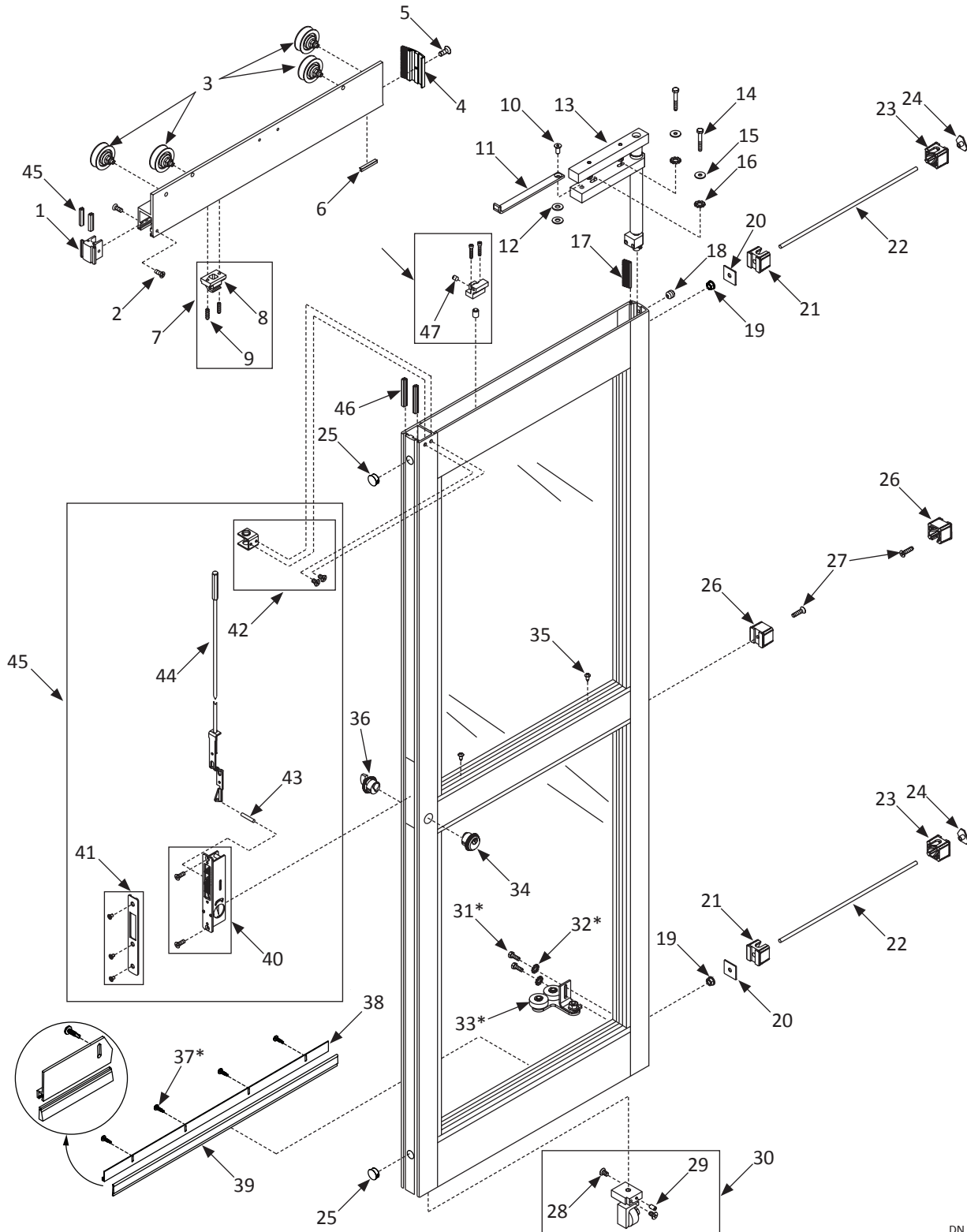

DN 1679



Fixed Sidelite Lead Door			
Item	Part	Finish/Sizes/Notes	Description
1	A-00628	Clear	END CAP:STRIKE END:LEAD DOOR:204
	A-70628	Dark Bronze	END CAP:STRIKE END:LEAD DOOR:313
2	T-00006	Zinc	FHSMS,10x0.750L.,PHIL,ZINC
	T-00005	Black Zinc	FHSMS,10x0.750L.,PHIL,BLK ZN
3	A-00961		"ROLLER HANGER,30mm;TELE & ICU"
4	A-00415	Clear	END CAP W/ BRUSH,7/16x1-7/8,204
	A-70415	Dark Bronze	END CAP W/ BRUSH,7/16x1-7/8,313
5	T-00176	Zinc	FHMS,10-32x0.500L.,PHIL,UCUT,23-PT,ZINC
	T-00183	Black Zinc	FHMS,10-32x0.500L.,PHIL,UCUT,23-PT,BLKZN
6	M-00690		WEATHER, PILE .2
7	A-00071		PANIC CATCH, UPPER,ASM.
8	M-00483		PANIC CATCH RELEASE ASSEMBLY
9	T-00091		SHSS,5/16-18x1.250L.,CUP PT.
10	T-00018		FHCS,7/16-14x1.000L.,ZINC
11	A-01167		LIMIT ARM,TELESCOPING SLIDER
12	T-00069		WASHER,.255 ID,.900 OD,.125 THK,NYLON
13	A-00092	Narrow Stile	CARRIER,PIVOT,NARROW STILE
	A-00165	Medium Stile	CARRIER, PIVOT ASSY, MED STILE
	A-00168	Narrow Panel & Narrow Stile	CARRIER PIVOT ASM. NRW PANEL & STILE
	A-00172	Narrow Panel; Medium Stile	CARRIER,PIVOT,ASM.,NRW.PNL - MED.STILE
14	T-00028		HHCS,1/4-20x1.750L.,GR5,ZINC
15	T-00029		WASHER,.250 ID,.563 OD,.049 THK,ZINC
16	T-00087		WASHER, LOCK, EXT, 1/4 ID, ZINC
17	A-00951		"BRUSH, NYLON, .56 LX1.875L."
18	T-00261		SHSS,5/16-24x0.500L.,CUP PT.
19	T-00025		NUT,WHIZLOCK,3/8-16,ZINC
20	M-00422		PLATE,TIE ROD
21	M-00461		CLIP,MUNTIN,.386 HOLE
22	M-00272		3/8-16 THREADED ROD
23	M-00460		CLIP,MUNTIN,.500 HOLE
24	M-00416		T-NUT, 3/8"-16, TIE ROD
25	T-00085		PLUG, DOME, .813 DIAMETER
26	M-00462		CLIP,MUNTIN,.261 HOLE
27	T-00061		FHMS,1/4-20x1.000L.,PHIL,TRI-LOBE,ZINC
28	T-00016	Zinc	FHMS,1/4-20x0.438L.,PHIL,UNDERCUT,ZINC
	T-00108	Black Zinc	FHMS,1/4-20x0.438L.,PHIL,UNDERCUT,BLK ZN
29	T-00105		SHSS,8-32x0.313L.,CUP PT.
30	A-00198	Narrow	NOSE CASTER ASSY, NAR
	A-00207	Medium	NOSE CASTER ASSY, MED
31	T-00064		HHCS,1/4-20x0.750L.,ZINC
32	T-00087		WASHER, LOCK, EXT, 1/4 ID, ZINC

Fixed Sidelite Lead Door			
Item	Part	Finish/Sizes/Notes	Description
33	A-00181	RH	BTM GUIDE DOUBLE ROLLER ASM, RH
	A-00183	LH	BTM GUIDE DOUBLE ROLLER ASM, LH
34	V-00123	Clear	CYLINDER,LOCK,KEYED,204
	V-70123	Dark Bronze	CYLINDER,LOCK,KEYED,313
35	T-00098		PHSMS,10x0.563L.,PHIL,TYPE A
36	V-00116	Clear	CYLINDER,LOCK,THUMBTURN,204
	V-70116	Dark Bronze	CYLINDER,LOCK,THUMBTURN,313
37	T-00222	Zinc	PHSMS,6x0.500L.,PHIL,TEKS,ZINC
	T-00260	Black Zinc	PHSMS,6x0.500L. PHIL,TEKS BLK ZN
38	M-60278	Clear	HOLDER,WEATHERING BRUSH,204,EXTRU
	M-70278	Dark Bronze	HOLDER,WEATHERING BRUSH,313,EXTRU
	M-90278	Bone White	HOLDER:WEATHERING BRUSH:BW:EXTRU
39	M-00274	Stepped	BRUSH, NYLON, 1" STEPPED
40	V-00005		LOCK, ADAMS-RITE #MS1853
41	V-00014	Clear	COVER,MS LOCK,W/ CUTOUT,204
	V-70014	Dark Bronze	COVER,MS LOCK,W/ CUTOUT,313
42	M-01634		LOCK GUIDE (SUB COMPONENT OF LOCK ROD)
43	T-00132		"PIN,ROLL,5/32D X 0.875L."
44	V-00094		LOCKROD, ADAMS-RITE #4015
45	A-00523		KIT,LOCK AND ROD
46	M-00688		PILE WEATHERING .45 TALL W/ ADHESIVE
47	T-00037		SHCS,1/4-20x1.250L.,ZINC
48	A-00069		PANIC CATCH, BOTTOM

### SERVICE PARTS: LEFT HAND FULL OPEN SIDELITE

Viewed from **Non-Break** Out Side

\* Sold in Parts Bag P/N A-00408

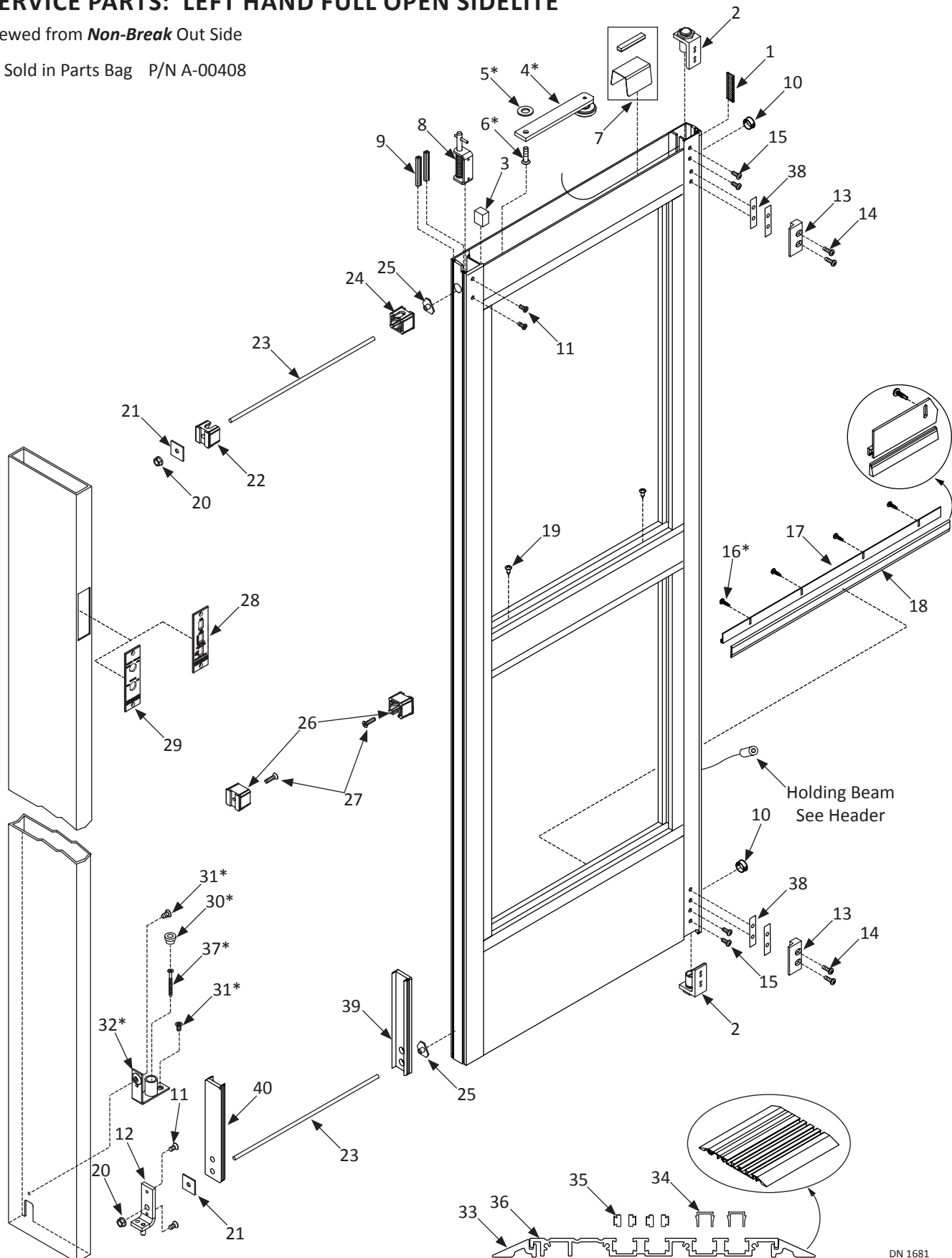

DN 1681

### SERVICE PARTS: RIGHT HAND FULL OPEN SIDELITE

Viewed from **Non-Break** Out Side

\* Sold in Parts Bag P/N A-00408

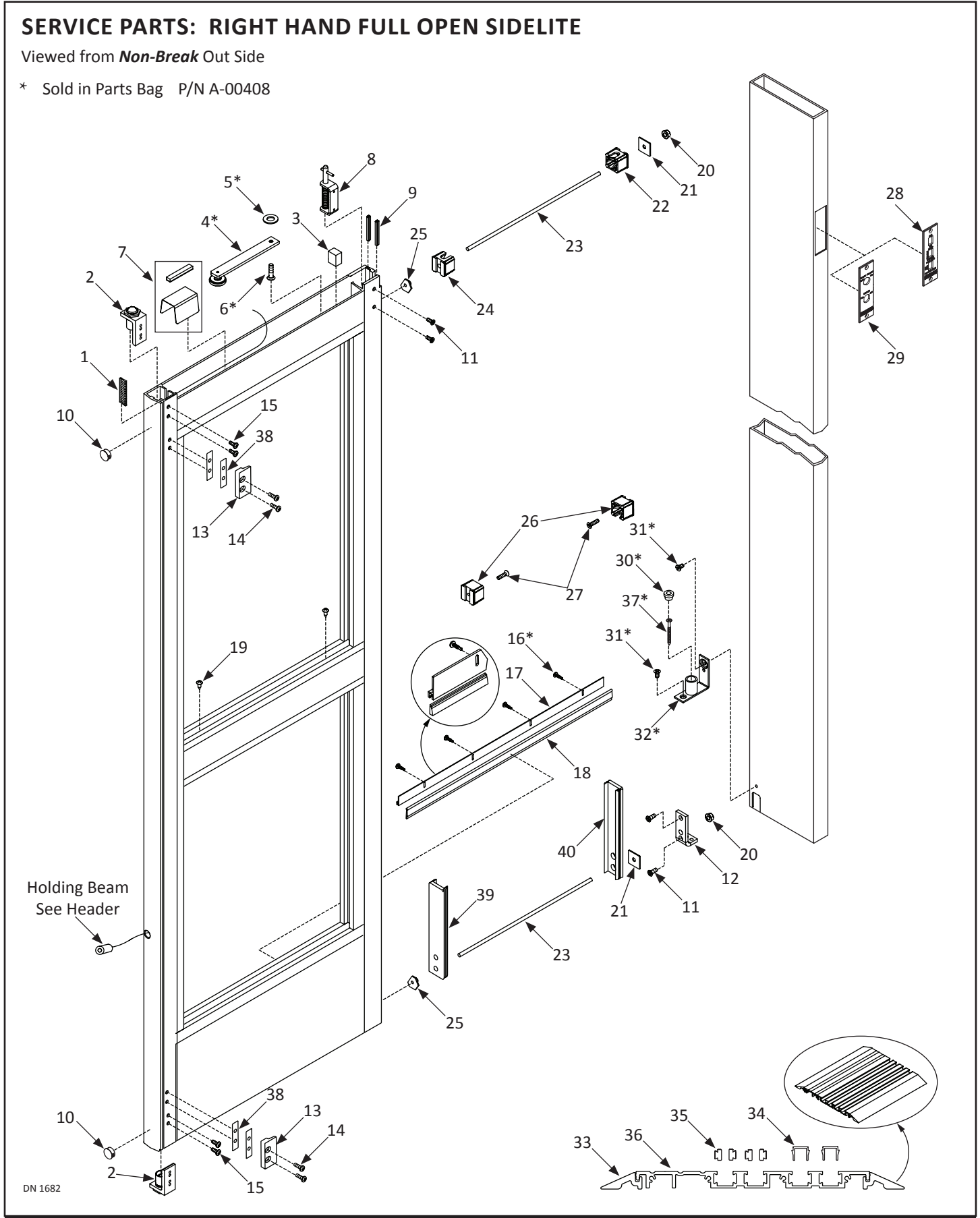

DN 1682

Full Open Sidelite			
Item	Part	Finish/Sizes/Notes	Description
1	A-00951		"BRUSH, NYLON, .56 LX1.875L."
2	A-00057		BALL DETENT,ASSEMBLY
3	A-00166		STOP BLOCK ASSY, SWING PANEL LIMIT ARM
4	A-00406		LIMIT ARM, SWING PANEL, MED STILE
	A-00060		LIMIT ARM,SWING PANEL,ASM.NRW.STILE
5	T-00069		WASHER,.255 ID,.900 OD,.125 THK,NYLON
6	T-00083		FHMS,1/4-20x1.000L.,PHIL,UCUT,VIBRATITE
7	A-00149		ASM, MAGNET, BREAKOUT
8	A-00029		ASM, TOP PIVOT, 1175 SWING PANEL
9	M-00687		WEATHERING, PILE .57 TALL
10	T-00085		PLUG, DOME, .813 DIAMETER
11	T-00016		FHMS,1/4-20x0.438L.,PHIL,UNDERCUT,ZINC
12	M-00593	LH	LH BOTTOM PIVOT SWING PANEL
	M-00594	RH	PIVOT, SWING PANEL,BTM,RH
13	M-01469		INTERLOCK:PLASTIC:1175
14	T-00078		PHMS,10-32x0.625L.,PHIL,ZINC
15	T-00027	Zinc	PHMS,10-32x0.500L.,PHIL.ZINC
	T-00051	Black Zinc	PHMS,10-32x0.500L.,PHIL,BLK ZN
16	T-00222	Zinc	PHSMS,6x0.500L.,PHIL,TEKS,ZINC
	T-00260	Black Zinc	PHSMS,6x0.500L. PHIL,TEKS BLK ZN
17	M-60278	Clear	HOLDER,WEATHERING BRUSH,204,EXTRU
	M-70278	Dark Bronze	HOLDER,WEATHERING BRUSH,313,EXTRU
	M-90278	Bone White	HOLDER:WEATHERING BRUSH:BW:EXTRU
18	M-00274		BRUSH, NYLON, 1" STEPPED
19	T-00098		PHSMS,10x0.563L.,PHIL,TYPE A
20	T-00025		NUT,WHIZLOCK,3/8-16,ZINC
21	M-00422		PLATE,TIE ROD
22	M-00461		CLIP,MUNTIN,.386 HOLE
23	M-00272		3/8-16 THREADED ROD
24	M-00460		CLIP,MUNTIN,.500 HOLE
25	M-00416		T-NUT, 3/8"-16, TIE ROD
26	M-00462		CLIP,MUNTIN,.261 HOLE
27	T-00061		FHMS,1/4-20x1.000L.,PHIL,TRI-LOBE,ZINC
28	M-01144	NABCO	SWITCH, KEY - NABCO
	M-01145	Porta Service	SWITCH, KEY - PORTA SERVICE
29	M-00428	NABCO	SWITCH MODULE,3 ROCKER,NABCO
	M-00429	Porta Service	SWITCH MODULE,3 ROCKER,PORTA
30	M-00606		BUSHING, BOTTOM PIVOT, SWING PANEL
31	T-00007		FHMS,1/4-20x0.500L.,PHIL,UNDRUCUT,F-PT,ZN
32	M-00611		FLOOR PIVOT BRACKET
33	M-60260		RAMP, THRESHOLD EXTENSION,204,EXTRU
34	M-00295		THRESHOLD, FILLER

Full Open Sidelite			
Item	Part	Finish/Sizes/Notes	Description
35	M-00291		THRESHOLD, BUMPER
36	M-60325		THRESHOLD,TELESCOPIC,7 X 1/2IN,204,EXTRU
37	T-00008		FHSMS,1/4x2.750L.,PHIL,TAPCON,BLUE
38	A-00391		KIT,SHIM,INTERLOCK
39	A-01254	For Optional 10" Rail only	CLIP, RAIL, 10,.500 HOLE
40	A-01253	For Optional 10" Rail only	CLIP, RAIL, 10,.391 HOLE

### SERVICE PARTS: LEFT HAND FULL OPEN TRAIL DOOR

Viewed from **Non-Break** Out Side

\* Sold in Parts Bag P/N A-00408

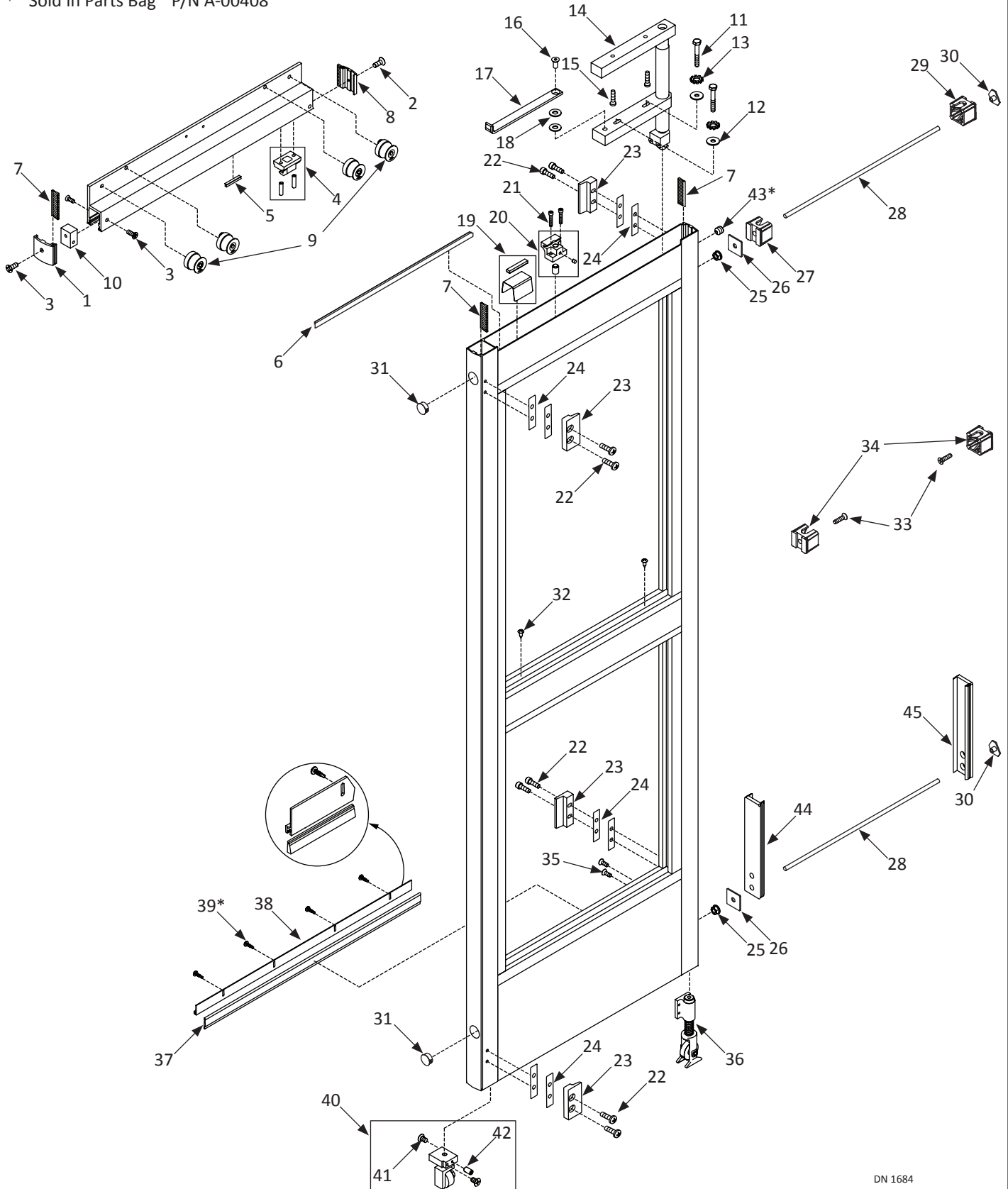

DN 1684

### SERVICE PARTS: RIGHT HAND FULL OPEN TRAIL DOOR

Viewed from *Non-Breakout* Out Side

\* Sold in Parts Bag P/N A-00408

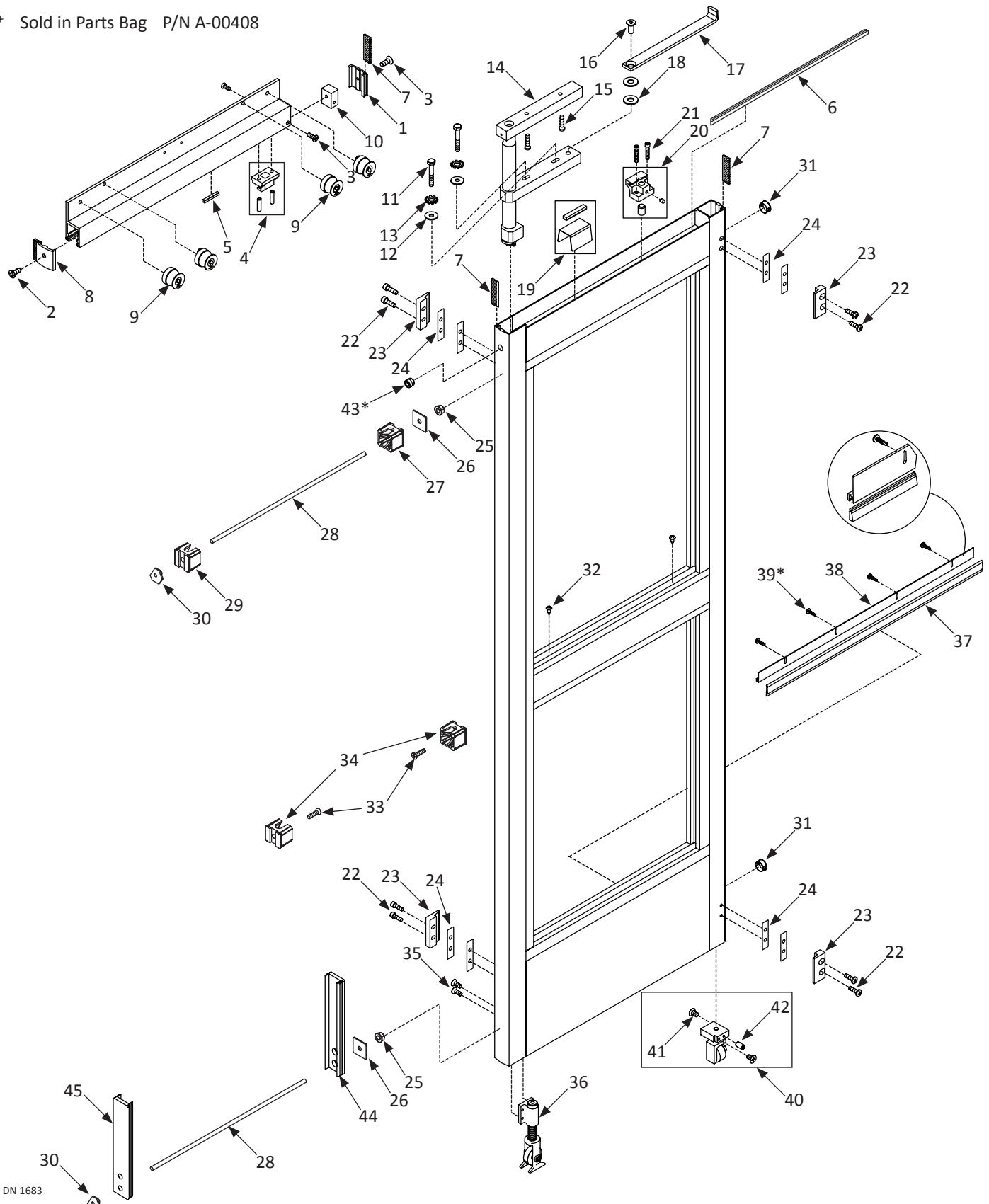

DN 1683



Full Open Trail Door			
Item	Part	Finish/Sizes/Notes	Description
1	M-01222	Clear	END CAP,BOTH ENDS,TRAIL DOOR,204
	M-71222	Dark Bronze	END CAP,BOTH ENDS,TRAIL DOOR,313
2	T-00176	Zinc	FHMS,10-32x0.500L.,PHIL,UCUT,23-PT,ZINC
	T-00183	Black Zinc	FHMS,10-32x0.500L.,PHIL,UCUT,23-PT,BLKZN
3	T-00006	Zinc	FHSMS,10x0.750L.,PHIL,ZINC
	T-00005	Black Zinc	FHSMS,10x0.750L.,PHIL,BLK ZN
4	A-00071		PANIC CATCH, UPPER,ASM.
5	M-00690		WEATHER, PILE .2
6	M-60288	Clear	INTERFACE LEG,204,EXTRU
	M-70288	Dark Bronze	INTERFACE LEG,313,EXTRU
7	A-00951		"BRUSH, NYLON, .56 LX1.875L."
8	A-00415	Clear	END CAP W/ BRUSH,7/16x1-7/8,204
	A-70415	Dark Bronze	END CAP W/ BRUSH,7/16x1-7/8,313
9	A-00961		"ROLLER HANGER,30mm;TELE & ICU"
10	M-01286		MOUNT BLOCK, END CAP - TRAIL DOOR
11	T-00028		HHCS,1/4-20x1.750L.,GR5,ZINC
12	T-00029		WASHER,.250 ID,.563 OD,.049 THK,ZINC
13	T-00087		WASHER, LOCK, EXT, 1/4 ID, ZINC
14	A-00092	Narrow Stile	CARRIER,PIVOT,NARROW STILE
	A-00165	Medium Stile	CARRIER, PIVOT ASSY, MED STILE
	A-00168	Narrow Panel & Stile	CARRIER PIVOT ASM. NRW PANEL & STILE
	A-00172	Narrow Panel & Medium Stile	CARRIER,PIVOT,ASM.,NRW.PNL - MED.STILE
15	T-00014		SHCS,3/8-16x1.500L.,LOW HD.
16	T-00018		FHCS,7/16-14x1.000L.,ZINC
17	A-01167		LIMIT ARM,TELESCOPING SLIDER
18	T-00069		WASHER,.255 ID,.900 OD,.125 THK,NYLON
19	M-00653		BRACKET, LIMIT ARM SUPPORT
20	A-00069		PANIC CATCH, BOTTOM
21	T-00037		SHCS,1/4-20x1.250L.,ZINC
22	T-00018		FHCS,7/16-14x1.000L.,ZINC
23	M-00440		INTERLOCK, PLASTIC, 1175
24	A-00391		KIT,SHIM,INTERLOCK
25	T-00025		NUT,WHIZLOCK,3/8-16,ZINC
26	M-00422		PLATE,TIE ROD
27	M-00461		CLIP,MUNTIN,.386 HOLE
28	M-00272		3/8-16 THREADED ROD
29	M-00460		CLIP,MUNTIN,.500 HOLE
30	M-00416		T-NUT, 3/8"-16, TIE ROD
31	T-00085		PLUG, DOME, .813 DIAMETER
32	T-00098		PHSMS,10x0.563L.,PHIL,TYPE A
33	T-00061		FHMS,1/4-20x1.000L.,PHIL,TRI-LOBE,ZINC
34	M-00462		CLIP,MUNTIN,.261 HOLE

Full Open Trail Door			
Item	Part	Finish/Sizes/Notes	Description
35	T-00027		PHMS,10-32x0.500L.,PHIL.ZINC
36	A-00063	Narrow Stile	ROLLER GUIDE,BOTTOM,ASM.
	A-00692	Medium Stile	CASTED BOTTOM ROLLER GUIDE ASSEMBLY
37	M-00274		BRUSH, NYLON, 1" STEPPED
38	M-60278	Clear	HOLDER,WEATHERING BRUSH,204,EXTRU
	M-70278	Dark Bronze	HOLDER,WEATHERING BRUSH,313,EXTRU
	M-90278	Bone White	HOLDER:WEATHERING BRUSH:BW:EXTRU
39	T-00222	Smoke Seal Only/Zinc	PHSMS,6x0.500L.,PHIL,TEKS,ZINC
	T-00260	Smoke Seal Only/Black Zinc	PHSMS,6x0.500L. PHIL,TEKS BLK ZN
40	A-00198	Narrow Stile	NOSE CASTER ASSY, NAR
	A-00207	Medium Stile	NOSE CASTER ASSY, MED
41	T-00016	Zinc	FHMS,1/4-20x0.438L.,PHIL,UNDERCUT,ZINC
	T-00108	Black Zinc	FHMS,1/4-20x0.438L.,PHIL,UNDERCUT,BLK ZN
42	T-00105		SHSS,8-32x0.313L.,CUP PT.
43	T-00019		SHSS,5/16-24x0.313L.,CUP PT.
44	A-01253	For Optional 10" Rail only	CLIP, RAIL, 10,.391 HOLE
45	A-01254	For Optional 10" Rail only	CLIP, RAIL, 10,.500 HOLE

### SERVICE PARTS: LEFT HAND FULL OPEN LEAD DOOR

Viewed from **Non-Break** Out Side

\* Sold in Parts Bag P/N A-00408

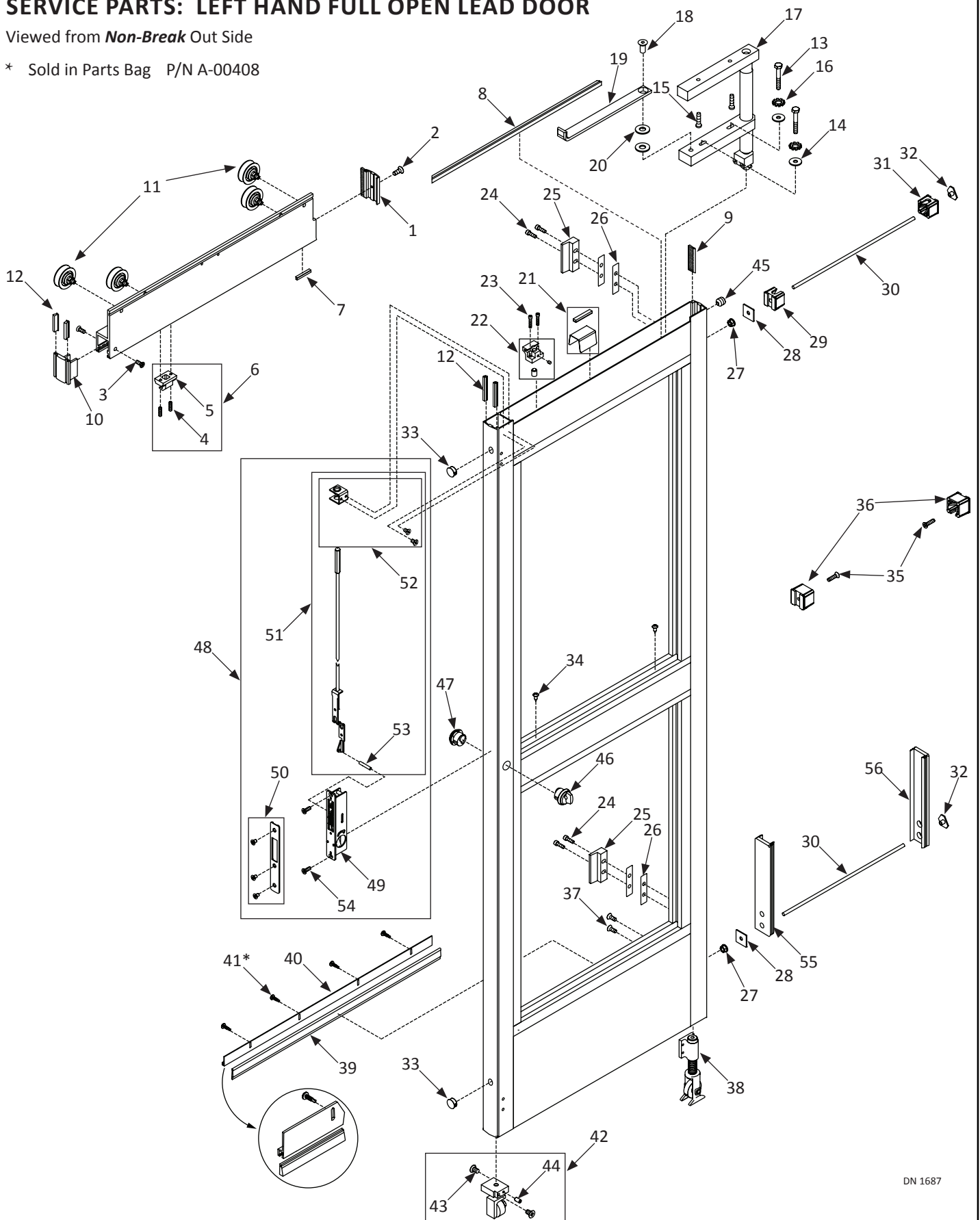

DN 1687

### SERVICE PARTS: RIGHT HAND FULL OPEN LEAD DOOR

Viewed from **Non-Breakout** Out Side

\* Sold in Parts Bag P/N A-00408

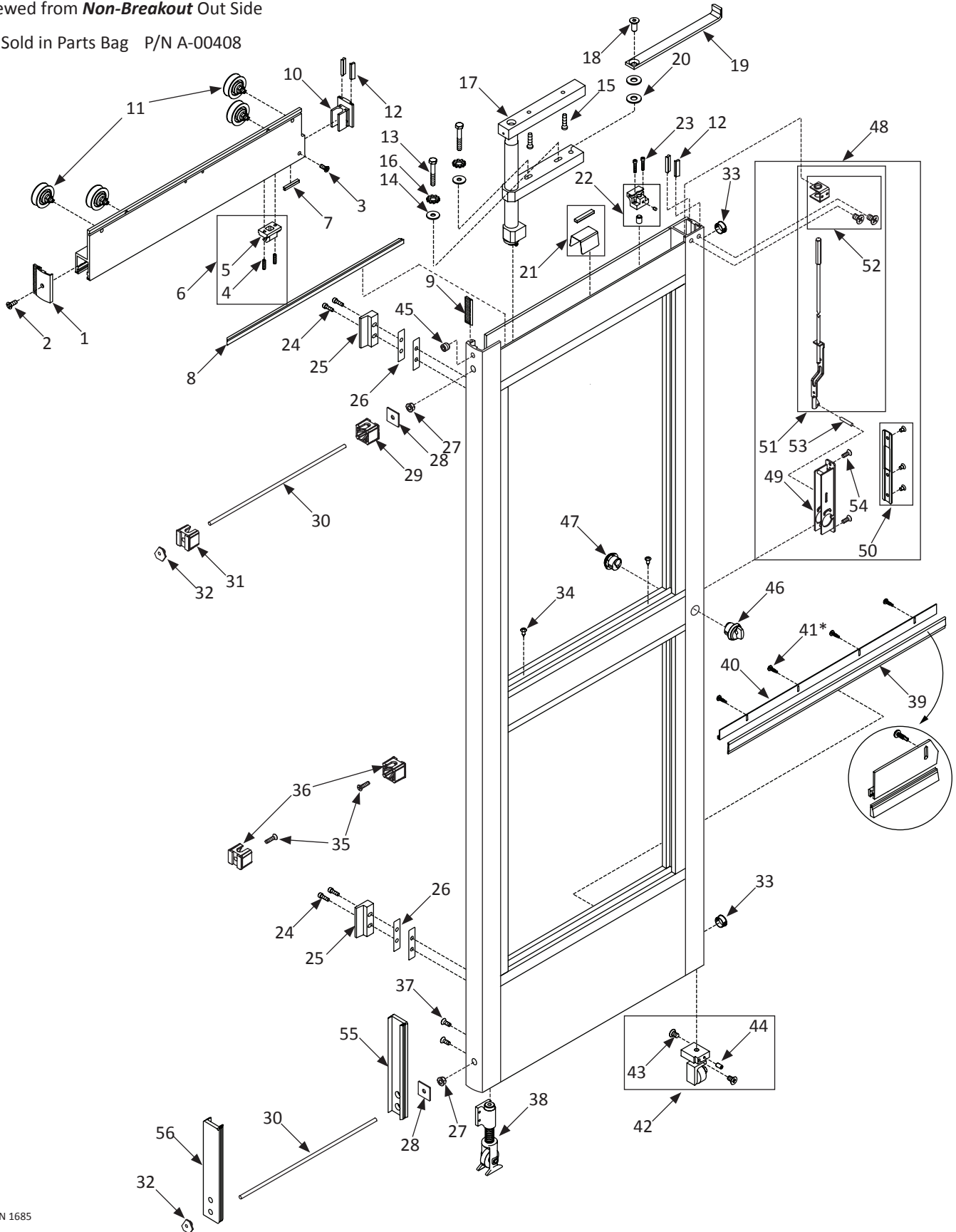

DN 1685

Full Open Lead Door			
Item	Part	Finish/Sizes/Notes	Description
1	A-00412	Clear	END CAP W/ BRUSH,PIVOT END LEAD DOOR,204
	A-70412	Dark Bronze	END CAP W/ BRUSH,PIVOT END LEAD DOOR,313
2	T-00176	Zinc	FHMS,10-32x0.500L.,PHIL,UCUT,23-PT,ZINC
	T-00183	Black Zinc	FHMS,10-32x0.500L.,PHIL,UCUT,23-PT,BLKZN
3	T-00006	Zinc	FHSMS,10x0.750L.,PHIL,ZINC
	T-00005	Black Zinc	FHSMS,10x0.750L.,PHIL,BLK ZN
4	T-00091		SHSS,5/16-18x1.250L.,CUP PT.
5	M-00483		PANIC CATCH RELEASE ASSEMBLY
6	A-00071		PANIC CATCH, UPPER,ASM.
7	M-00690		WEATHER, PILE .2
8	M-60288	Clear	INTERFACE LEG,204,EXTRU
	M-70288	Dark Bronze	INTERFACE LEG,313,EXTRU
9	A-00951		"BRUSH, NYLON, .56 LX1.875L."
10	A-61250	Clear	END CAP,STRIKE END-LEAD DOOR,SGL,204
	A-71250	Dark Bronze	END CAP, STRIKE END-LEAD,SGL,313
11	A-00961		"ROLLER HANGER,30mm;TELE & ICU"
12	M-00688		PILE WEATHERING .45 TALL W/ ADHESIVE
13	T-00028		HHCS,1/4-20x1.750L.,GR5,ZINC
14	T-00029		WASHER,.250 ID,.563 OD,.049 THK,ZINC
15	T-00014		SHCS,3/8-16x1.500L.,LOW HD.
16	T-00087		WASHER, LOCK, EXT, 1/4 ID, ZINC
17	A-00092	Narrow Stile	CARRIER,PIVOT,NARROW STILE
	A-00165	Medium Stile	CARRIER, PIVOT ASSY, MED STILE
	A-00168	Narrow Panel and Stile	CARRIER PIVOT ASM. NRW PANEL & STILE
	A-00172	Narrow Panel and Medium Stile	CARRIER,PIVOT,ASM.,NRW.PNL - MED.STILE
18	T-00018		FHCS,7/16-14x1.000L.,ZINC
19	A-01167		LIMIT ARM,TELESCOPING SLIDER
20	T-00069		WASHER,.255 ID,.900 OD,.125 THK,NYLON
21	M-00653		BRACKET, LIMIT ARM SUPPORT
22	A-00069		PANIC CATCH, BOTTOM
23	T-00037		SHCS,1/4-20x1.250L.,ZINC
24	T-00018		FHCS,7/16-14x1.000L.,ZINC
25	M-00440		INTERLOCK, PLASTIC, 1175
26	A-00391		KIT,SHIM,INTERLOCK
27	T-00025		NUT,WHIZLOCK,3/8-16,ZINC
28	M-00422		PLATE,TIE ROD
29	M-00461		CLIP,MUNTIN,.386 HOLE
30	M-00272		3/8-16 THREADED ROD
31	M-00460		CLIP,MUNTIN,.500 HOLE
32	M-00416		T-NUT, 3/8"-16, TIE ROD
33	T-00085		PLUG, DOME, .813 DIAMETER
34	T-00098		PHSMS,10x0.563L.,PHIL,TYPE A

Full Open Lead Door			
Item	Part	Finish/Sizes/Notes	Description
35	T-00061		FHMS,1/4-20x1.000L.,PHIL,TRI-LOBE,ZINC
36	M-00462		CLIP,MUNTIN,.261 HOLE
37	T-00027		PHMS,10-32x0.500L.,PHIL.ZINC
38	A-00063	Narrow Stile	ROLLER GUIDE,BOTTOM,ASM.
	A-00692	Medium Stile	CASTED BOTTOM ROLLER GUIDE ASSEMBLY
39	M-00274		BRUSH, NYLON, 1" STEPPED
40	M-60278	Clear	HOLDER,WEATHERING BRUSH,204,EXTRU
	M-70278	Dark Bronze	HOLDER,WEATHERING BRUSH,313,EXTRU
	M-90278	Bone White	HOLDER:WEATHERING BRUSH:BW:EXTRU
41	T-00222	Smoke Seal Only/Zinc	PHSMS,6x0.500L.,PHIL,TEKS,ZINC
	T-00260	Smoke Seal Only/Black Zinc	PHSMS,6x0.500L. PHIL,TEKS BLK ZN
42	A-00198	Narrow Stile	NOSE CASTER ASSY, NAR
	A-00207	Medium Stile	NOSE CASTER ASSY, MED
43	T-00016	Zinc	FHMS,1/4-20x0.438L.,PHIL,UNDERCUT,ZINC
	T-00108	Black Zinc	FHMS,1/4-20x0.438L.,PHIL,UNDERCUT,BLK ZN
44	T-00105		SHSS,8-32x0.313L.,CUP PT.
45	T-00019		SHSS,5/16-24x0.313L.,CUP PT.
46	V-00116	Thumbturn/Clear	CYLINDER,LOCK,THUMBTURN,204
	V-70116	Thumbturn/Dark Bronze	CYLINDER,LOCK,THUMBTURN,313
47	V-00123	Keyed/Clear	CYLINDER,LOCK,KEYED,204
	V-70123	Keyed/Dark Bronze	CYLINDER,LOCK,KEYED,313
48	A-00523		KIT,LOCK AND ROD
49	V-00005		LOCK, ADAMS-RITE #MS1853
50	V-00014	Clear	COVER,MS LOCK,W/ CUTOUT,204
	V-70014	Dark Bronze	COVER,MS LOCK,W/ CUTOUT,313
51	V-00094		LOCKROD, ADAMS-RITE #4015
52	M-01634		LOCK GUIDE (SUB COMPONENT OF LOCK ROD)
53	T-00132		"PIN,ROLL,5/32D X 0.875L."
54	T-00043	Zinc	FHMS,10-24x0.375L.,PHIL,UNDERCUT,ZINC
	T-00045	Black Zinc	FHMS,10-24x0.375L.,PHIL,UNDERCUT,BLK ZN
55	A-01253	For Optional 10" Rail only	CLIP, RAIL, 10,.391 HOLE
56	A-01254	For Optional 10" Rail only	CLIP, RAIL, 10,.500 HOLE

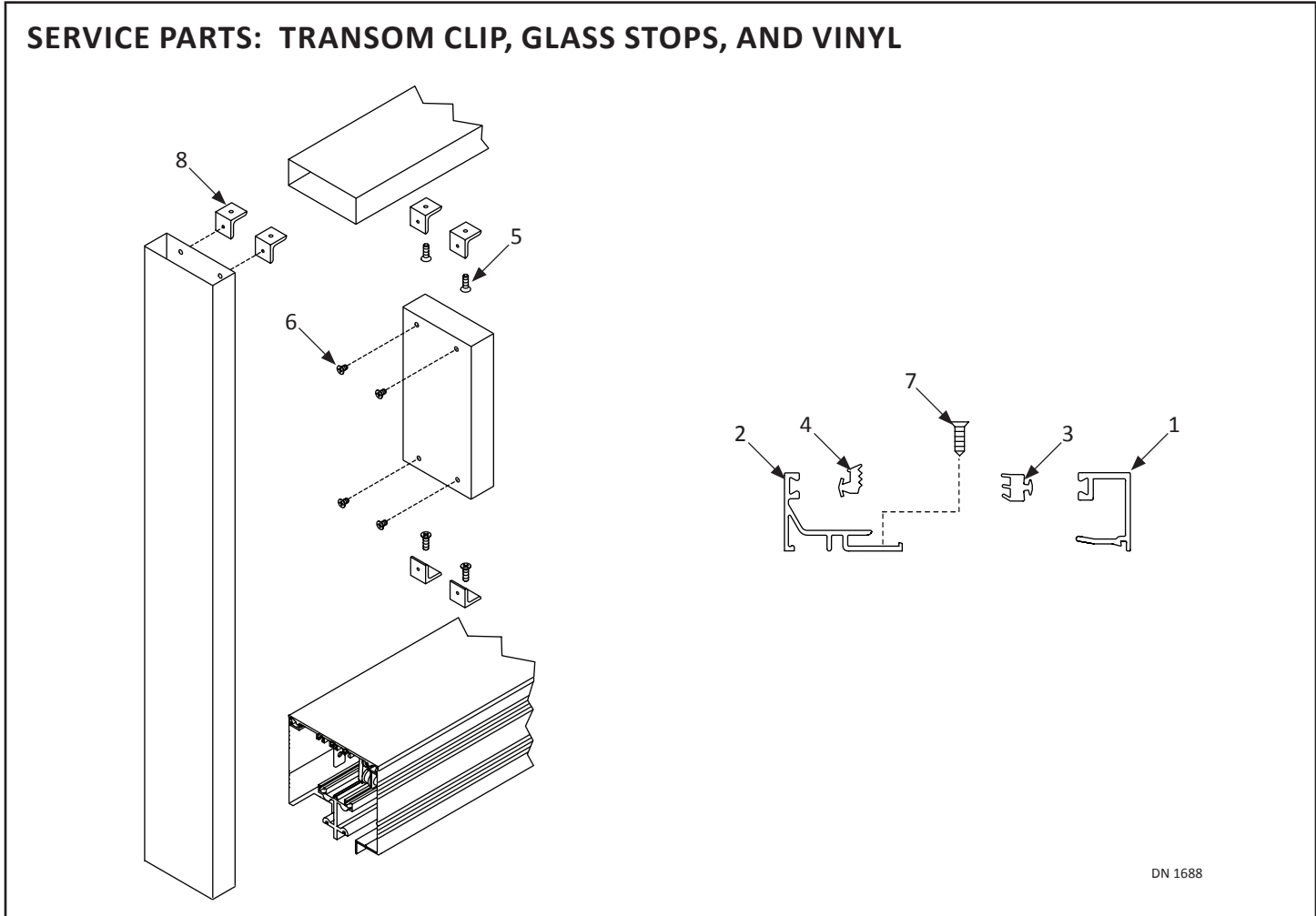

DN 1688

Transom Glass Stops, and Vinyl			
Item	Part	Finish/Sizes/Notes	Description
1	M-60333	Clear	GLASS STOP, TOP, 1" TALL, 204 ,EXTRU
	M-70333	Dark Bronze	GLASS STOP, TOP, 1" TALL, 313 ,EXTRU
2	M-60266	Clear	GLASS STOP, SCREW DOWN, BASE, 204, EXTRU
	M-70266	Dark Bronze	GLASS STOP, SCREW DOWN, BASE, 313, EXTRU
3	M-00263		VINYL GLASS STOP THREE PRONG
4	M-00284		VINYL GLASS STOP TEAR DROP
5	T-00424		"FHMS, 10-24x0.625L., F PT., PHIL, ZN"
6	T-00016	Zinc	FHMS, 1/4-20x0.438L., PHIL, UNDERCUT, ZINC
	T-00108	Black Zinc	FHMS, 1/4-20x0.438L., PHIL, UNDERCUT, BLK ZN
7	T-00137		"FHSMS, 8x0.625L., PHIL, TYPE A"
8	M-01386		BRACKET, FRAME, 7IN TRAN