



## GT1175 U-19 Electric Lock Retrofit Kit Quick Setup Parts Guide

P/N 15-12499-031 Rev 12-19-14

Nabco Entrances Inc. 582 W18717 Gemini Drive Muskego, Wisconsin 53150  
Phone: (877) 622-2694 Fax: (888) 679-3319 www.nabcoentrances.com

*Associated Manuals Part Numbers: "1175 Electrical Installation Manual U19 & Earlier" Rev 5-18-04 (P/N 15-10596)*

**WARNING**

- Turn OFF all power to the Automatic Door if a Safety System is not working.
- Instruct the Owner to keep all power turned OFF until corrective action can be achieved by a NABCO trained technician. Failure to follow these practices may result in serious consequences.
- NEVER leave a Door operating without all Safety detection systems operational.

### Table of Contents

SECTION 1: RETROFIT THE BELT CLIP .....	3
SECTION 2: INSTALL THE ELECTRIC LOCK .....	4
SECTION 3: CHANGE HANDING OF SLIDE DOOR .....	4
SECTION 4: U19 WITH FAIL SECURE OR FAIL SAFE ELECTRIC LOCK .....	5
SERVICE PARTS: U-19 ELECTRIC LOCK RETROFIT KIT .....	6

**THIS PAGE IS INTENTIONALLY LEFT BLANK**

**SECTION 1: Retrofit the Belt Clip**

*Note: Electric Locks can not prevent Breakout. If preventing Breakout is deemed necessary, panic hardware must be fitted to the Door Panels.*

1. Remove (2) 1/4-20 x 1 inch Hex Head screws used to secure the Belt Clip to the Belt Bracket. Save the spacers, screws and lock washers for reinstallation.
  - a. Ensure the Belt Clip stays intact with the Belt, so the Belt does not lose Belt Tension.
2. Remove (2) 1/4-20 x 3/4 inch Hex Head screws used to secure the Belt Bracket to the Carrier. Save screws for reinstallation.
3. Obtain the Belt Clip Assembly provided within the Electric Lock Retrofit Kit.
4. Review the Belt Clip Assembly to ensure the secured position will match Figure 1 and Figure 2.
  - a. If necessary rotate the Latch so the Flat Side of Latch faces the Terminal Strip located on the Lock Assembly.



5. Secure the Belt Bracket to the Belt Clip with (2) 1/4-20 x 1 inch Hex Head screws, lock washers, and spacers that were saved for reinstallation. Do not overtighten the screws.
  - a. Ensure the Belt Clip is in the correct position (Top vs Bottom) as shown in Figure 2.
6. Secure the Belt Bracket to the Carrier with (2) 1/4-20 x 3/4 inch Hex Head screws that were saved for reinstallation. Do not overtighten the screws.

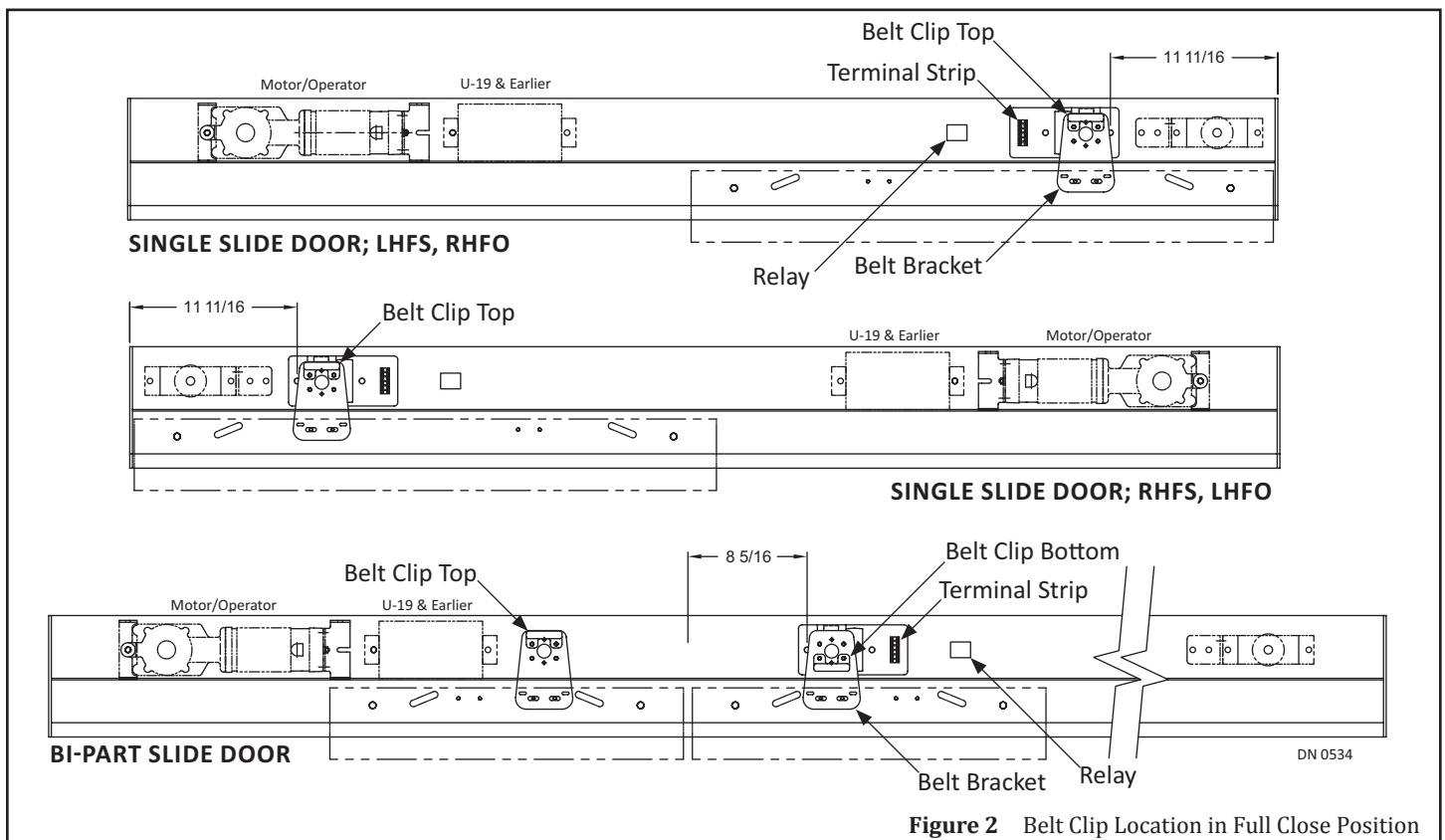

## SECTION 2: Install the Electric Lock

1. Insert (2) 3/8 -16 x 3/4 inch T-Bolts into the Channel located inside Header and turn clockwise so they do not fall out.

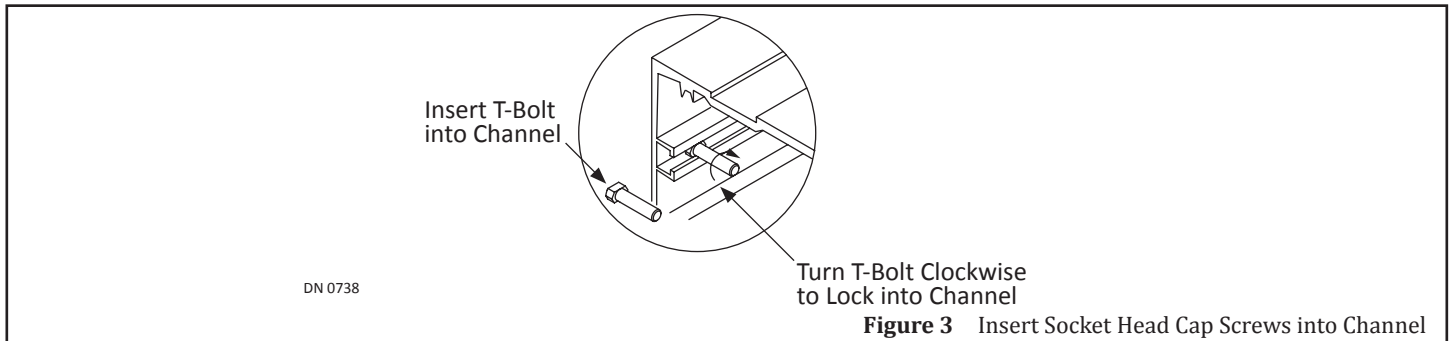

2. Obtain the Electric Lock provided within the Electric Lock Retrofit Kit.
3. Place the Electric Lock over the (2) 3/8-16 x 3/4 inch T-Bolts.
  - a. Ensure the Terminal Strip is facing the Pivot side of Slide Door.
4. Loosely secure the Electric Lock to the T-Bolts with (2) 3/8-16 Whizlock nuts.
5. Position the Electric Lock so the Strike is directly behind the Latch when the Slide door is in the Fully Closed Position. Please see Figure 4.
  - a. Ensure there is a slight gap between the Strike Wall and Flat of Latch.

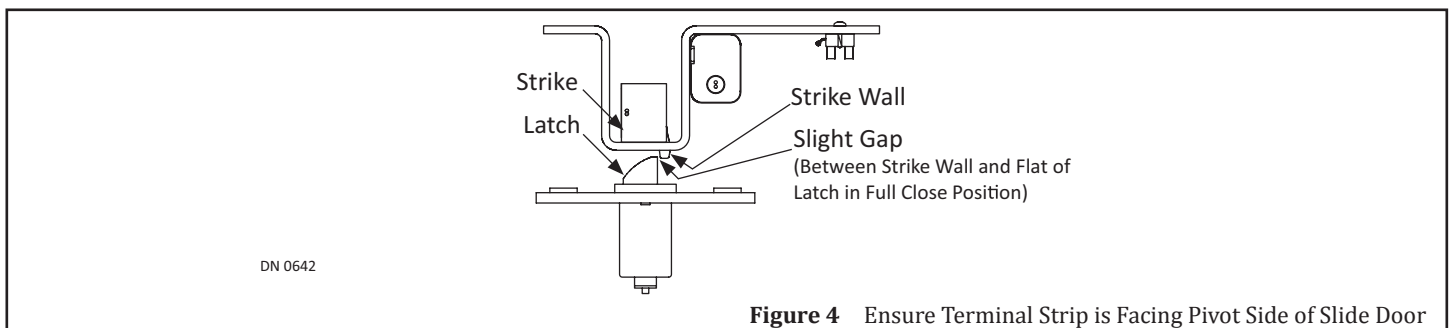

6. Tighten (2) 3/8-16 Whizlock nuts to secure the Electric Lock to the Channel.
7. Wire the Electric Lock. Please see Section 4.

## SECTION 3: Change Handing of Slide Door

*Note: Handing of the Slide Door is only necessary if the Slide Door: Opens when it should Close; or Closes when it should Open.*

1. Obtain the Handing Harness provided within the Parts Bag.
2. Go to the Motor Harness that is connected to the Motor and the U-19 Microprocessor Control.
3. Separate the Motor Harness to connect the Handing Harness between the connectors.

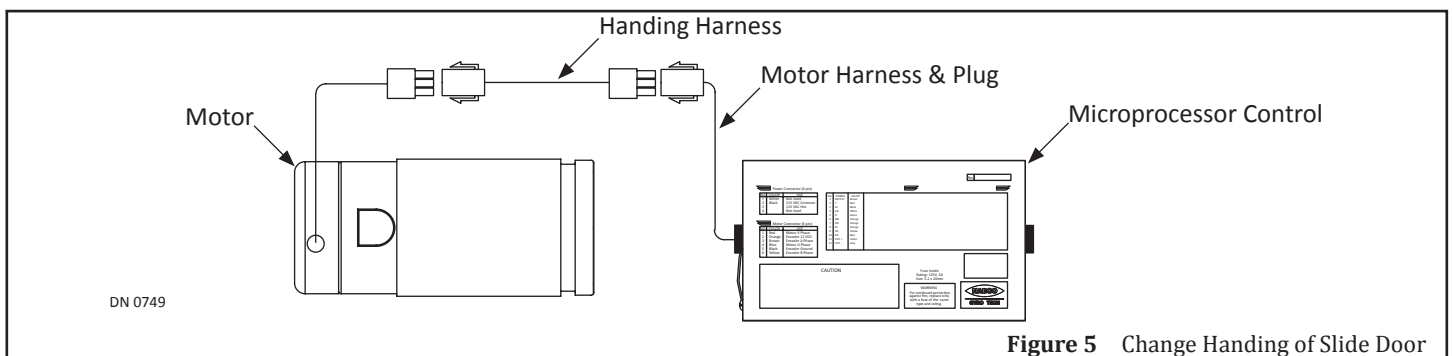

### SECTION 4: U19 with Fail Secure or Fail Safe Electric Lock

Note: Electric Lock only works in One Way mode or Night Mode.

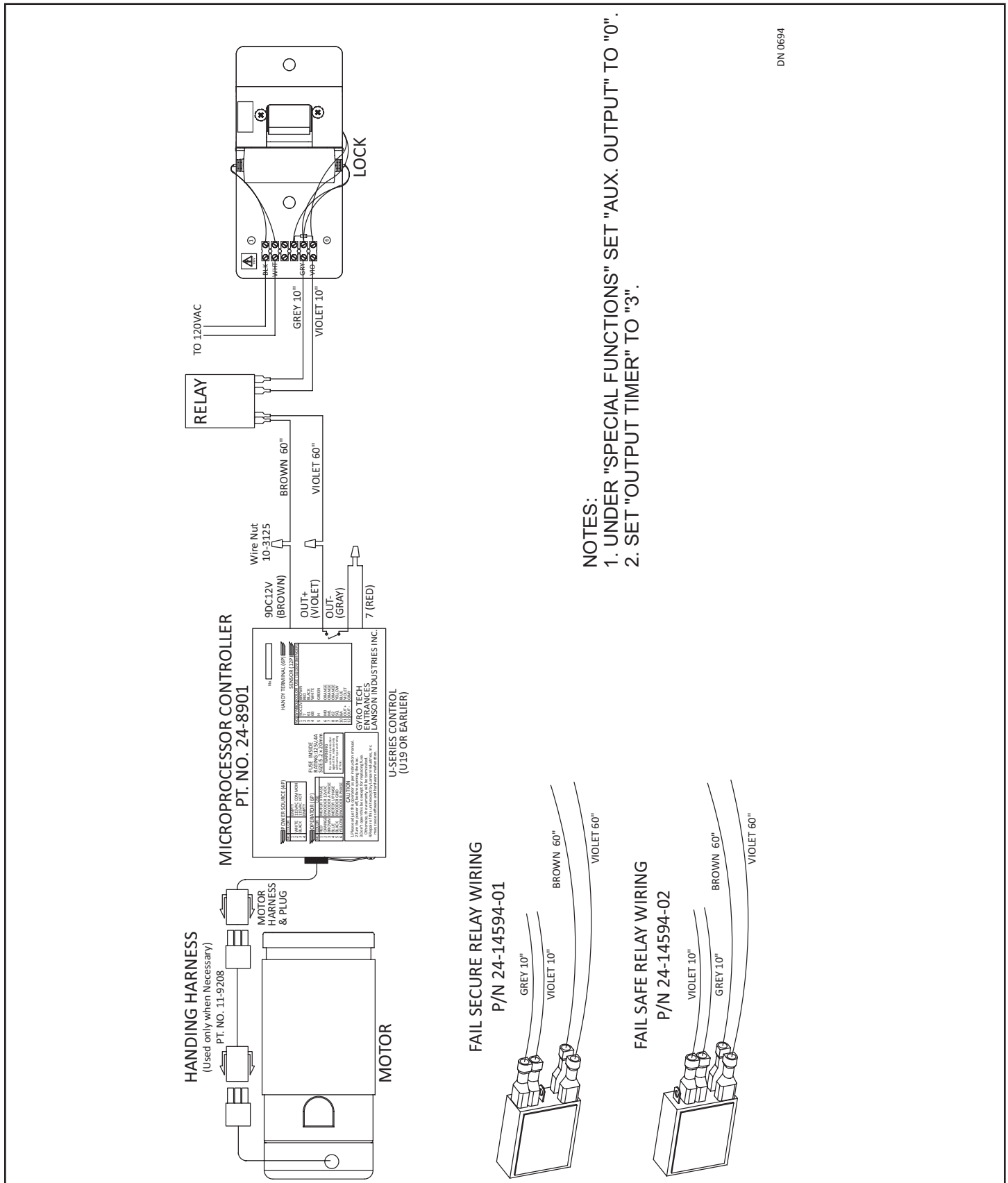

### SERVICE PARTS: U-19 ELECTRIC LOCK RETROFIT KIT

P/N 21-11658-03 Fail Secure

P/N 21-11658-04 Fail Safe

\* Sold in Parts Bag; P/N 12-10599-01 Fail Secure

Sold in Parts Bag; P/N 12-10599-02 Fail Safe

\*\* Not Sold in Retrofit Kit

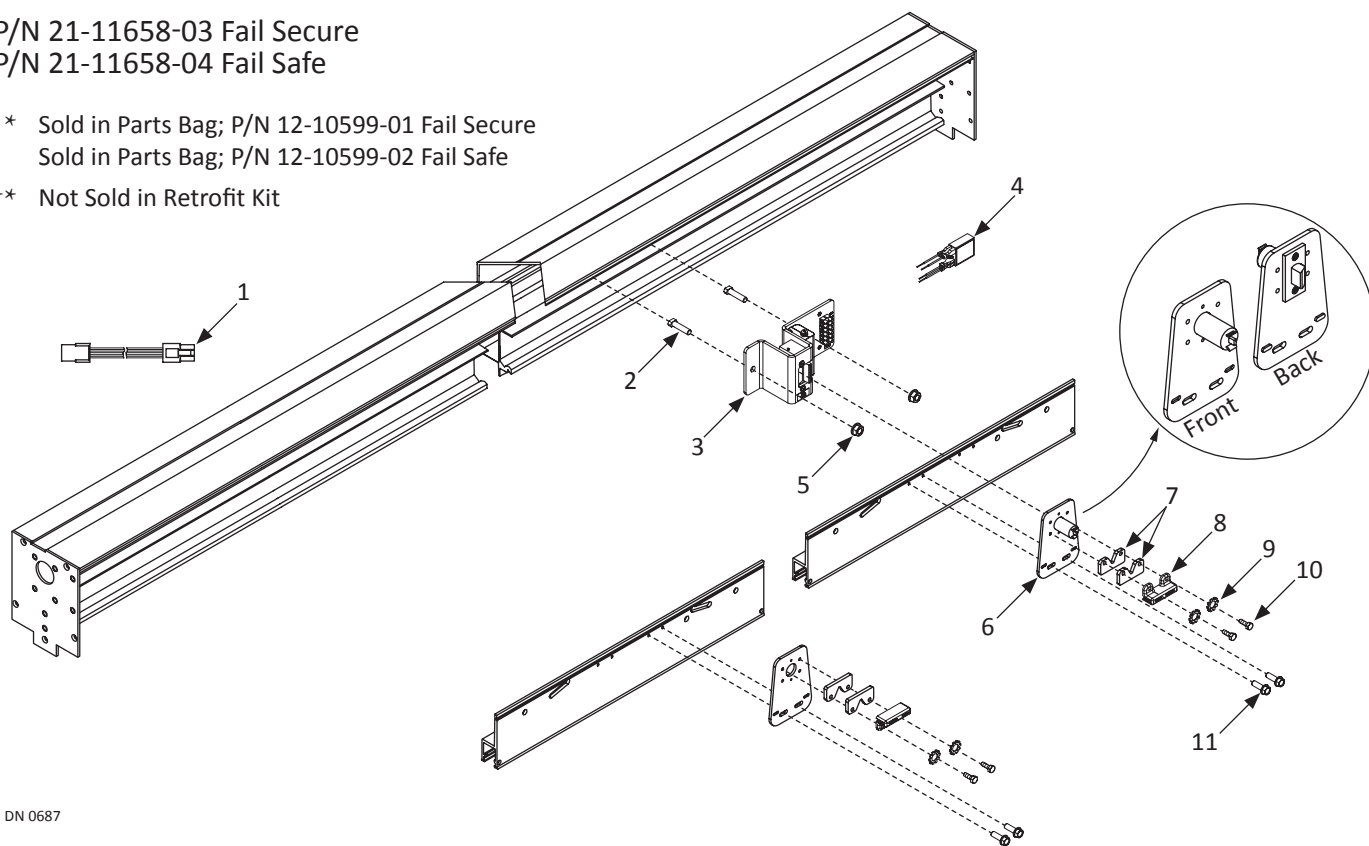

DN 0687

Header				
Item	Part	Finish/Sizes/Notes	Header	Description
1	11-9208			HARNES, HANDING, U-19 MICROPROCESSOR
2	14-14592			T-BOLT, 3/8"-16 X .75 LG
3	22-10522-03	Fail Secure		VON DUPRIN FAIL SEC ELE STRIKE SUB ASSY
	22-10522-04	Fail Safe		VON DUPRIN FAIL SAFE ELE STRIKE SUB ASSY
4	24-14594-01	Fail Secure		ASM, RELAY - FAIL SECURE, ELECTRIC LOCK
	24-14594-02	Fail Safe		ASM, RELAY - FAIL SAFE, ELECTRIC LOCK
5	24-0021-21			NUT, WHIZLOCK, 3/8-16, ZN
6	14-12104-10			BELT BRACKET, ELECTRIC LOCK ASSEMBLY
7	14-11870			SPACER, BELT CLIP, 1175
8	24-11493			CLIP, BELT
9	24-0019-05			1/4" EXTERNAL STAR WASHER
10	24-0014-01			HHCS, 1/4-20 X 1", ZN
11	24-0014-15			HHCS, 1/4-20 X 3/4, ZN