



Model GT1175 Slide Doors Owner's Manual

P/N C-00109 Rev 11-11-19

Nabco Entrances Inc. S82 W18717 Gemini Drive Muskego, Wisconsin 53150
Phone: (877) 622-2694 Fax: (888) 679-3319 www.nabcoentrances.com
NABCO hours of Operation: Monday to Friday 8:00 a.m.- 4:30 p.m. (Central Time)

**GT1175 Slide Door
OWNER'S MANUAL**

**A Founding Member of: AAADM
(American Association of Automatic Door Manufacturers)**

WARNING

- Turn OFF all power to the Automatic Door if a Safety System is not working.
- Instruct the Owner to keep all power turned OFF until corrective action can be achieved by a NABCO trained technician. Failure to follow these practices may result in serious consequences.
- NEVER leave a Door operating without all Safety detection systems operational.

Table of Contents

CHAPTER 1: WARNING LABELS 2

CHAPTER 2: GENERAL SAFETY RECOMMENDATIONS 2

CHAPTER 3: SCOPE. 2

SECTION 3.1: To the Customer 2

SECTION 3.2: Objective 2

CHAPTER 4: GETTING STARTED 2

SECTION 4.1: Service Availability 3

SECTION 4.2: Safety Standard Compliance 3

SECTION 4.3: Limited Warranty 3

SECTION 4.4: Information Provided by Door Supplier 3

CHAPTER 5: OPERATION 3

CHAPTER 6: GENERAL SAFETY 4

CHAPTER 7: SENSORS 5

Section 7.1: Sensor Types 5

Section 7.2: Sensor Malfunctions. 5

CHAPTER 8: DAILY SAFETY CHECK 6

Section 8.1: Slide Door and Floor Area 6

Section 8.2: Detection Zone 7

Section 8.3: Two-Way Traffic. 7

Section 8.4: One-Way Traffic. 8

CHAPTER 9: SAFETY DECALS. 8

CHAPTER 1: WARNING LABELS

Please refer to this section in the event a warning label within this manual needs further explanation.

WARNING Indicates a hazardous situation which has some probability of *severe injury*. It should not be considered for property damage unless personal injury risk is present.

CAUTION Indicates a hazardous situation which may result in a *minor injury*. Caution should not be used when there is a possibility of serious injury. Caution should not be considered for property damage accidents unless a personal injury risk is present.

Notice: Indicates a statement of company policy as the message relates to the personal safety or protection of property. Notice should not be used when there is a hazardous situation or personal risk.

Note: Indicates important information that provides further instruction.

CHAPTER 2: GENERAL SAFETY RECOMMENDATIONS

WARNING An improperly adjusted door can cause injury and/or equipment damage.

WARNING Safety devices must be installed correctly and operational.

WARNING Do Not operate any Slide Door Unit without fully understanding how a Slide Door functions. If you do not fully understand, ask a qualified technician. Failure to do so may result in bodily injury, or property damage and will nullify all warranties.

Notice: This manual must be given to and retained by the purchasing facility or end user.

Notice: Inspect door operation daily using the Daily Safety Checklist (within this manual and on door).

Notice: Have door inspected at least annually by an AAADM certified inspector.

CHAPTER 3: SCOPE

SECTION 3.1: To the Customer

The purpose of this manual is to familiarize the Owner with proper operation of the door. It is essential that the Owner recognizes the importance of maintaining a door system in compliance with industry standards for safety.

It is the responsibility of the Owner/Caretaker to inspect operation of the door on a daily basis. Daily inspection must be done to ensure safe door operation for use by pedestrians, including (but not limited to) invitees, customers, or employees. This manual covers all GT1175 Slide Doors.

SECTION 3.2: Objective

This manual provides maintenance instruction, and a daily safety checklist, plus instructions for a daily safety checklist.

WARNING Should the door fail to operate as prescribed in the Daily Safety Check, or at any other time for any other reason, DO NOT attempt to repair or adjust the door. Call an AAADM Certified technician. These technicians are trained to service automatic door systems in accordance with ANSI/BHMA A156.10 (Full Automatic).

CHAPTER 4: GETTING STARTED

Automatic sliding doors are available in single slide, bi-part slide and telescopic slide configurations. As a rule, these are furnished as complete packages and can be surface mounted or concealed overhead (in-transom mounted). Slide doors typically include: an operator, header, track, carrier wheels, sliding door panel(s), sidelite panel(s), jambs, lock and activation/safety system. No matter the configuration or system, automatic Slide Doors:

- ▶ Must include Sensors and Signage for the safety and convenience of the user.
- ▶ Have a Safety Zone to cover the area the door travels.
- ▶ Plan traffic routing so persons will approach the door straight on and not from an angle.

SECTION 4.1: Service Availability

Door products are distributed through a nationwide network of authorized suppliers for sales, installation, and service. Immediately contact the Door Manufacturer or the Authorized Door Manufacturer Representative, if service must be performed on an automatic door system.

SECTION 4.2: Safety Standard Compliance

The automatic door system was designed to comply with the latest operating and safety standards. To ensure continued, safe operation it is important that:

- ▶ The door system is maintained in compliance with industry standards.
- ▶ Proper decals/labels are applied and maintained on doors.
- ▶ All doors should be checked by an AAADM certified inspector at least annually.

The American Association of Automatic Door Manufacturers, has established a program to certify automatic door inspectors. Through this program, inspectors are trained to check door systems for compliance with the appropriate version of an ANSI standard. In the United States, ANSI Standard 156.10 (Used to cover Full Automatic doors) applies.

SECTION 4.3: Limited Warranty

NABCO Entrances Inc., for its Gyro-Tech product line, provides to its customer a limited warranty on products. The warranty is:

NABCO ENTRANCES INC. will exchange or repair, F.O.B. the plant, any component found defective in workmanship and/or material, subject to NABCO's inspection, for a period of one (1) year after installation or 18 months after manufacture, whichever comes first. Warranty does not include field service labor. The installing contractor/customer will be responsible for installation and field service. This is NABCO ENTRANCES Inc.'s sole warranty.

This warranty does not cover loss or damages resulting from causes beyond the manufacturer's control, misuse, neglect, accidents, windstorms, or other acts of God, or acts of terrorism. Warranty is for normal use and service. The warranty does not apply to equipment that has been repaired or altered so as to adversely affect conditions of operation. Warranty will not obligate NABCO for damages resulting from such alterations, misuse, or acts of God, or acts of terrorism.

SECTION 4.4: Information Provided by Door Supplier

Note: To obtain an AAADM Daily Safety Check video, please go to <http://www.aaadm.com/doorowners.asp>

- ▶ Instruction on how to conduct the Daily Safety Check.
- ▶ Location of activation Switches and Sensors with instruction of their use.
- ▶ Circuit breaker or main power disconnect location for each door system.
- ▶ Contact number to call for service, or inquiries about the Door system, and/or to report concerns.
- ▶ An AAADM inspection form, or a Work Order signed by an AAADM certified inspector.
- ▶ Affixed to the Door, a completed Annual Compliance Inspection label, at the bottom of the Safety Information label.
- ▶ Warranty information for each door.

CHAPTER 5: OPERATION

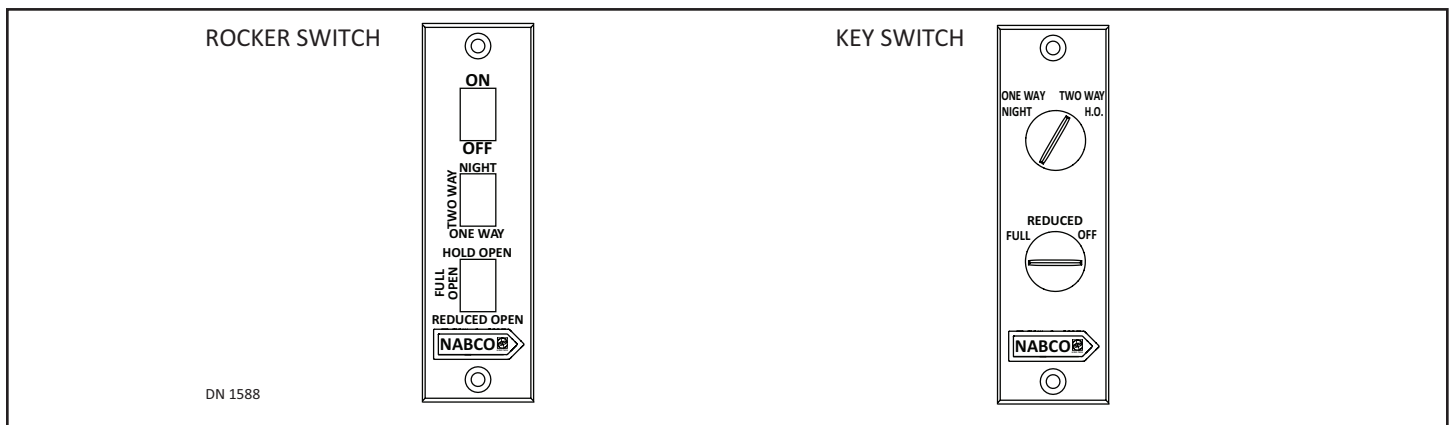

DN 1588

Rocker Switch and Key Switch	
Switch	Description
ON	When the switch is in ON position, the window is operational.
OFF	When the switch is in the OFF position, the window is not operational. The OFF position does not shut off the main power to the window unit.
TWO-WAY	Both Sensors are activated for Two-Way traffic.
ONE-WAY	<ul style="list-style-type: none"> ▶ The Electric Lock (if installed) will lock the door in the fully closed position. ▶ The signal from the Exterior Sensor will not Open the door. ▶ The System will still allow people to Exit the building utilizing the Interior Sensor. ▶ Both Sensors provide Threshold protection during the door cycle.
NIGHT	<ul style="list-style-type: none"> ▶ The Electric Lock (if installed) will lock the door in the fully closed position. ▶ Neither Sensor will open the door. ▶ Door activation must be generated from a wall switch or a card reader. ▶ Both Sensors provide Threshold protection during the door cycle.
HOLD OPEN	<ul style="list-style-type: none"> ▶ Door is held Open as long as the Switch remains in the Hold Open position. ▶ Doors should be held Open in this manner. Do Not prop open the doors with any object.
FULL OPEN	When the switch is in FULL OPEN position, the Window Fully opens with an activation signal.
REDUCED OPEN	<ul style="list-style-type: none"> ▶ Doors open to specification preset during installation. For example: In bad weather or while air conditioning is on, the width of the Opening in the reduced Open Mode is adjustable. ▶ Contact a qualified service technician for adjustment.

CHAPTER 6: GENERAL SAFETY

Pay attention to the following safety items and perform checks periodically where noted.

- ▶ Force (Force can be measured with a force gauge):
 - Force to prevent the door from closing should not exceed 30 pounds.
 - If the door is equipped, force to Breakout the door should not exceed 50 pounds.
 - Force to open door in the event of a power failure should not exceed 30 pounds.
- ▶ If equipped, Breakout Mode:
 - When the door (or door including a Sidelite) is pushed into Breakout mode, check that the door will not activate. For details, please call customer service at: (877) 622-2694.
- ▶ Strike Stile:
 - With door open, grasp the Strike Stile of door and attempt to move it vertically and horizontally. There should be very little, if any, looseness between door and glass, and/or connections between door and operator.

Maximum Closing Speed - 1 Foot per Second		
Nominal Door Opening		Minimum Closing Time to
Single	Bi-Part	Within 6 inches of Closed
	48"	2 seconds
	60"	2-1/2 seconds
36"	72"	3 seconds
42"	84"	3-1/2 seconds
48"	96"	4 seconds

CHAPTER 7: SENSORS

The GT1175 Slide Door System can utilize a Sensor that activates the Slide Door with Infrared/Microwave technology, or Infrared technology, depending upon the brand.

- ▶ Sensor with Microwave/Infrared technology: Has a deeper detection zone and accommodates fast traffic conditions.
- ▶ Sensor with Infrared technology: Used to scan backwards to detect pedestrians in the threshold until the Slide door is fully closed.

Section 7.1: Sensor Types

7.1.1 Motion Sensor

Motion Sensors are used to activate the door when it detects a moving object, such as a pedestrian or a shopping cart. Motion sensors can typically distinguish between objects moving toward the door or away from the door. Motion sensors cannot detect still objects such as a person stopped in the Detection Zone.

7.1.2 Presence Sensor

Presence Sensors detect both moving and non-moving objects in the path of the door and signal the Control Unit accordingly. NABCO Entrances utilizes infrared technology in its presence sensors.

7.1.3 Motion/Presence Sensor

Motion/Presence Sensors provide motion detection, and pedestrian safety.

Section 7.2: Sensor Malfunctions

Table 1 Some (not all) Common cause examples for Sensor Malfunctions

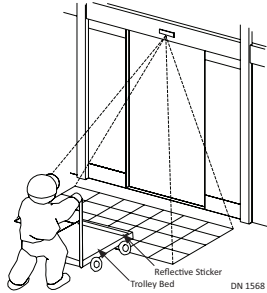
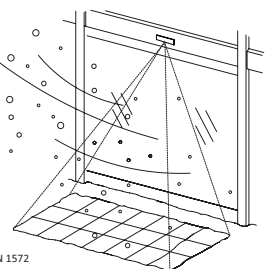
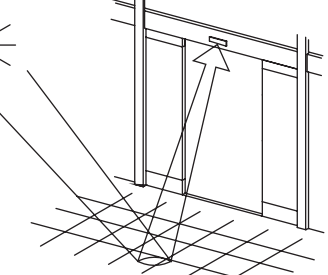
<p>The bed of a trolley:</p> <ul style="list-style-type: none"> ▶ Is too low to the floor ▶ Surface of cart or trolley is not reflective enough to be detected. (Reflective tape or stickers can help) 	 <p style="text-align: right;">Reflective Sticker Trolley Bed DN 1568</p>
<p>Sensor is exposed to:</p> <ul style="list-style-type: none"> ▶ Steam ▶ Exhaust fume ▶ Insects ▶ Heavy rain ▶ Heavy snow 	 <p style="text-align: right;">DN 1572</p>
<p>Presence Detection Zone is flooded with:</p> <ul style="list-style-type: none"> ▶ Strong direct Sunlight ▶ Sunlight reflecting from floor (such as marble, or aluminum floors) ▶ Strong direct artificial light ▶ Artificial light reflecting from floor (such as marble, or aluminum floors) ▶ Lighting fixtures placed too close to the Sensor 	 <p style="text-align: right;">DN 1570</p>

Pool of water located within Presence Detection Zone

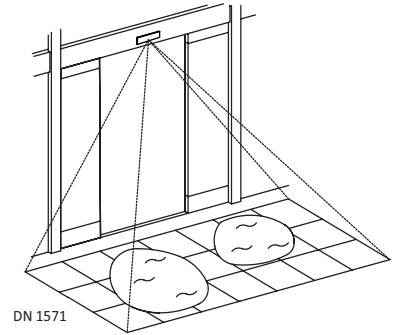

An object placed within the Presence Detection Zone that may be moving within the detection zone (like due to wind).

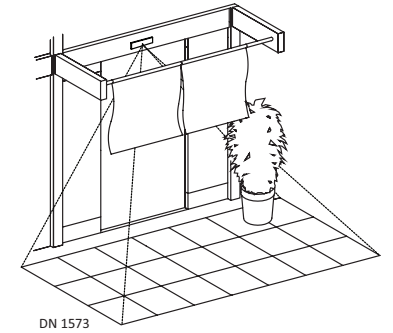

Multiple Sensors installed close to each other, or facing each other

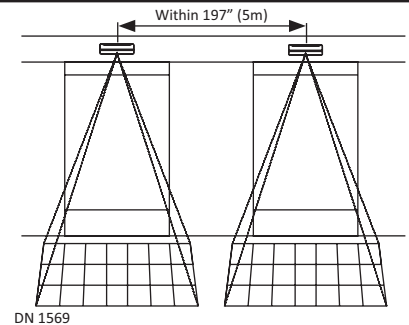

CHAPTER 8: DAILY SAFETY CHECK

CAUTION If the Swing Door will not be used for at least (1) month, it is recommended to turn Power OFF to the Unit.

CAUTION As a preventive measure, any components showing signs of wear must be replaced by a qualified, NABCO trained technician, or service provider. In order to guarantee reliability of the installation, any components showing signs of wear must be replaced as a preventive measure.

CAUTION As a preventive measure, any components showing signs of wear must be replaced by a qualified, NABCO trained technician, or service provider.

Attention: In the event any type of object needs to be removed from the Sensor Detection Zone (vicinity), the Sensor will keep the door open until it "relearns" the zone before resuming normal operation. This may take a minute or two.

The best time to perform a Daily Safety Check is early in the morning while pedestrian traffic is still restricted from Sensor activating zones. The purpose of a Daily Safety Check is to ensure pedestrian safety and Owner protection.

Section 8.1: Slide Door and Floor Area

1. Ensure the Power Breaker is switched ON. Do not switch Power Breaker ON and OFF too quickly.
2. Ensure the Rocker Switch or Key Switch is set to "ON".
3. Check the motion of the Slide door. Slide door should slide freely.
4. If Equipped: Test Emergency Break Out. In Break Out mode, the door must not activate. Call your supplier for details.

5. Ensure Full Open Sidelite doors are fully closed. Failure to do so, will disrupt proper door operation.
 - a. In the event a Sidelite is ajar, swing open the Sidelite about 2 feet, and then fully close it.
6. Inspect the floor area. It should be clean with no loose parts that might cause user to trip or fall. Keep traffic path clear.
7. Inspect door's overall condition. The appropriate signage should be present and hardware should be in good condition.
8. Ensure the Header Cover, and all other hardware is properly secured.
9. Check for damaged or missing Weathering.
10. Check for damaged or missing Finger Guards.
11. Ensure Door Latches operate smoothly.
12. Check all glass for cracks or damage.
13. Remove tripping or slipping hazards.
14. Sweep out or vacuum Threshold (if equipped) to remove rocks, dirt and/or debris.
 - a. NABCO recommends that associates, maintenance, and personnel be trained to clean Thresholds and Threshold Channels during the daily duties of cleaning the floors.

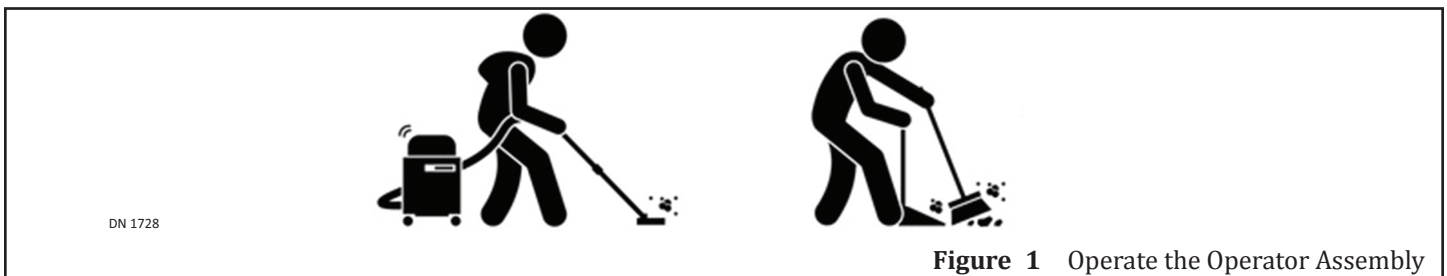

Figure 1 Operate the Operator Assembly

Section 8.2: Detection Zone

1. Observe traffic pattern to the Slide door.
 - a. Plan traffic pattern so pedestrians approach the door straight on (not from an angle).
2. At about (12) inches away from the door face, walk parallel towards the center of the door opening.
 - a. Ensure the Detection Zone is at least as wide as the door opening.
3. Fully open the Slide door. Crouch motionless in the Threshold for at least (10) seconds. The door should not contact the pedestrian.
4. If Holding Beams are installed:
 1. Open the window. Block the Beam with your Hand.
 - a. The Window should not be able to close.

Section 8.3: Two-Way Traffic

1. Go to the Exterior side of Door. Walk toward the Slide door at a moderate speed. At about (4) feet away, the door should start to open and then stop without impact.
 1. Door must remain fully open for a minimum of (1.5 seconds) after loss of detection.
 2. Closing time to Latch Check shall be a maximum of (1 foot per second) measured at the leading edge.
 3. Latch Check shall occur at no less than 2 inches from the closed position measured per door panel.
2. Move slowly through the door opening (about 6 inches per second). The door should not contact the pedestrian.
3. Continue to move slowly through the Detection Zone. The door should not contact the pedestrian.
4. Walk out of the Detection Zone.
 - a. After a brief time delay (at least 1-1/2 seconds), the door should fully close without impact.
 - b. Slide doors must be adjusted if they close faster than (1) foot per second.
5. Go to the Interior side of Door. Repeat steps.



Figure 2 Walk through Detection Zone

Section 8.4: One-Way Traffic

GT1175 Slide Doors are typically installed with (1) Sensor on each side of the Header. In the event a Slide door is still in the process of closing, and a pedestrian is detected within a minimum of (24) inches from the door, the Inactive Sensor will still provide safety by fully re-opening the door.

1. Go to the Activated Sensor side of Door. Walk toward the Slide door at a moderate speed. At about (4) feet away, the door should fully open and then stop without impact.
2. Move slowly through the door opening (about 6 inches per second). The door should not contact the pedestrian.
3. Continue to move slowly through the Detection Zone. The door should not contact the pedestrian.
4. Walk out of the Detection Zone.
 - a. After a brief time delay (at least 1-1/2 seconds), the door should fully close without impact.
 - b. Slide doors should be adjusted so they do not close faster than (1) foot per second.

CHAPTER 9: SAFETY DECALS

Doors shall be equipped with signage visible from either side of the door, instructing the user as to the operation and function of the door. The signs shall be mounted 50" +/- 12" (1270 mm +/- 305 mm) from the floor to the center line of the sign. The letters shall be 5/8 inch (16 mm) high minimum.

Description		
In Emergency Push to Open	Affixed adjacent to the Strike Stile on a center line (36 to 60) inches from the floor, applied to the side of door appropriate for egress.	
Caution Stand Clear	Affixed on an adjacent Sidelite or Wall, (36 to 60) inches from the floor.	
Automatic Sliding Door	Two Sided. Affixed on the Lead Door so the signage is visible from both sides of the door. Same is true for Telescopic Slide Door Units. Do Not affix the Decal on the Trail door.	
AAADM Safety Information Label	Affixed to Door Frame in a visible, protected location.	