



# Acusensor M Installation Manual

P/N C-00187 Rev 2-14-19

Nabco Entrances Inc. 582 W18717 Gemini Drive Muskego, Wisconsin 53150  
Phone: (877) 622-2694 Fax: (888) 679-3319 www.nabcoentrances.com  
NABCO hours of Operation: Monday to Friday 8:00 a.m.- 4:30 p.m. (Central Time)

## **WARNING**

- Turn OFF all power to the Automatic Door if a Safety System is not working.
- Instruct the Owner to keep all power turned OFF until corrective action can be achieved by a NABCO trained technician. Failure to follow these practices may result in serious consequences.
- NEVER leave a Door operating without all Safety detection systems operational.

## **ATTENTION**

**!! BULLETIN #86 MUST BE READ !!  
PLEASE REFER TO THE BACK OF THIS MANUAL**

### *Table of Contents*

<b>CHAPTER 1: SAFETY</b> .....	<b>3</b>
SECTION 1.1: Warning Labels .....	3
SECTION 1.2: General Safety Recommendations .....	3
<b>CHAPTER 2: SCOPE</b> .....	<b>4</b>
SECTION 2.3: To the Installer .....	4
SECTION 2.4: Objective .....	4
<b>CHAPTER 3: SPECIFICATIONS</b> .....	<b>4</b>
<b>CHAPTER 4: PRESENCE DETECTION AREA</b> .....	<b>5</b>
<b>CHAPTER 5: INSTALL THE ACUSENSOR M</b> .....	<b>8</b>
SECTION 5.1: Secure Sensor to Header .....	8
SECTION 5.2: Install the Angled Spacer (Sold Separately) .....	8
<b>CHAPTER 6: WIRE THE ACUSENSOR M</b> .....	<b>9</b>
SECTION 6.1: Wire Swing Door with Monitoring (Opus Control) .....	9
SECTION 6.2: Wire Fold Door with Monitoring (Opus Control) .....	10
SECTION 6.3: Wire Slide Door with Monitoring (U30 Control) .....	10
<b>CHAPTER 7: SWITCH SETTINGS 1-8</b> .....	<b>10</b>
SECTION 7.1: Operation Mode (Switches 1 and 2) .....	11
SECTION 7.2: Output Logic (Switch 3) .....	12
SECTION 7.3: Input Logic (Switch 4) .....	12
SECTION 7.4: Width Setting (Switches 5 thru 8) .....	13

**CHAPTER 8: SWITCH SETTINGS 9-20 ..... 13**

SECTION 8.1: Depth Setting (Switches 9 thru 11) ..... 14

SECTION 8.2: Learn Time (Switches 12 and 13) ..... 17

SECTION 8.3: Anti-Noise (Switch 14) ..... 17

SECTION 8.4: Anti-Environment (Switches 15 and 16) ..... 17

SECTION 8.5: Sensitivity (Switches 17 and 18) ..... 18

SECTION 8.6: IP Mode (Switches 19 and 20) ..... 18

**CHAPTER 9: AREA ADJUSTER ..... 18**

**SERVICE PARTS: ACUSENSOR M ..... 20**

## CHAPTER 1: SAFETY

### SECTION 1.1: Warning Labels

Warning labels are universal and used to alert an individual of potential harm to one's self or to others. The following warning labels are listed in a hierarchy order that defines the most potential danger first, and the least potential danger last.

#### **DANGER**

Indicates potentially dangerous situations. Danger is used when there is a hazardous situation where there is a *high* probability of severe injury or death. It should not be considered for property damage unless personal injury risk is present.

#### **WARNING**

Indicates a hazardous situation which has *some* probability of severe injury. It should not be considered for property damage unless personal injury risk is present.

#### **CAUTION**

Indicates a hazardous situation which *may result in a minor injury*. Caution should not be used when there is a possibility of serious injury. Caution should not be considered for property damage accidents unless a personal injury risk is present.

**Attention:** A situation where material could be damaged or the function impaired.

**Notice:** Indicates a statement of company policy as the message relates to the personal safety or protection of property. Notice should not be used when there is a hazardous situation or personal risk.

*Note:* Indicates important information that provides further instruction.

### SECTION 1.2: General Safety Recommendations

#### **DANGER**

Do not place finger or uninsulated tools inside the electrical controller. Touching wires or other parts inside the enclosure may cause electrical shock, serious injury or death.

#### **WARNING**

Disconnect power at the fused disconnect during all electrical or mechanical service. When uncertain whether power supply is disconnected, always verify using a voltmeter.

#### **CAUTION**

If the door appears broken or does not seem to work correctly, it should be immediately removed from service until repairs can be carried out or a qualified service technician is contacted for corrective action.

**Notice:** Read, study and understand the operating instructions contained in, or referenced in this manual before operating. If you do not understand the instruction, ask the installing qualified technician to teach you how to use the door.

**Notice:** This manual must be given to and retained by the purchasing facility or end user.

**Notice:** Advise the purchasing facility or end user to make regular safety checks and all other duties that may apply.

**Notice:** All electrical troubleshooting or service must be performed by qualified electrical technicians and must comply with all applicable governing agency codes.

**Attention:** DO NOT install the Acusensor M on a Transom. The infrared beam may be interrupted, causing Doorway Monitoring malfunction.

**Attention:** Check for total current consumption of Devices being connected to the Motor/Operator. In the event current consumption is exceeded, malfunction or failure may be caused.

*Note:* To prevent misunderstanding, explain to Owner in advance: When [Doorway 1] or [Doorway 2] is used, the door may be opened and closed several times to learn the door condition after power-on or after the environment changed significantly.

## CHAPTER 2: SCOPE

### SECTION 2.3: To the Installer

The purpose of this manual is to familiarize the installer and purchaser with the proper installation and operation of the Acusensor M. It is essential that this equipment be properly installed and operational before the door is used by the public. It is the installer's responsibility to inspect the operation of the entrance system to be sure it complies with any applicable standards. In the United States, ANSI Standard 156.10 (Full Energy) covers these types of doors. Other local standards or codes may apply. Use them in addition to the ANSI standard.

Instruct the building owners and operator on the essentials of the operation of the door and this device. The owner should follow these instructions to determine whether the door is operating properly and should immediately call for service if there is any malfunction. All installation changes and adjustments must be made by qualified, NABCO trained technicians.

If after troubleshooting a problem, a satisfactory solution cannot be achieved, please call Nabco Entrances at 1-877-622-2694 between 8 am – 4:30 pm Central time for additional assistance.

### SECTION 2.4: Objective

Acusensor M is mounted on the Header Cover for all Slide Door Units, Swing Door Units, and Fold Door Units. The Acusensor M is used to detect changes of multiple near-infrared rays that beam from the Sensor down to various points on the floor. The Acusensor M can detect a moving pedestrian or object, or a stationary pedestrian or object. Upon Presence Detection, the Acusensor M outputs a detection signal to Control. The Control automatically sends a signal to the Motor/Operator, the Motor/Operator opens the automatic door.

The Acusensor M was developed based on the concept of safety, comfort, reliability and multipurpose.

## CHAPTER 3: SPECIFICATIONS

### WARNING

**All wiring must conform to standard wiring practices and be in accordance with national and local electrical codes.**

*Note: It is recommended for the Installer to use an Electrical Conduit to house all incoming 120 VAC wires.*

**Table 1** General Specifications

Specification	Description		
Sensing System	Active reflective near infrared system (Motion/Presence)		
Life Expectancy	(5) years. LED illuminates a: <ul style="list-style-type: none"> <li>▶ White light during Learning that blinks twice every (5) seconds</li> <li>▶ Green light during Normal Operation that blinks twice every (5) seconds <ul style="list-style-type: none"> <li>• Flashing LEDs do not indicate that the Sensor is failing.</li> <li>• Flashing LEDs indicate that the Sensor has been in use for a period of time, and replacement is recommended. This is done to ensure continued safe operation of the door.</li> </ul> </li> </ul>		
Applicable door	Sliding door/Swing door/Folding door		
Detection Area	<ul style="list-style-type: none"> <li>▶ Without angled spacer <ul style="list-style-type: none"> <li>• Width 114”(2.9m) x Depth 71”(1.8m) (at mounting height 87”(2.2m))</li> </ul> </li> <li>▶ With angled spacer (sold separately) <ul style="list-style-type: none"> <li>• Width 114”(2.9m) x Depth 78”(2.0m) (at mounting height 87”(2.2m))</li> </ul> </li> </ul> <p>The width and depth of a Detection Area may vary. For details, please refer to Table 3-1. This is typically the result of:</p> <ul style="list-style-type: none"> <li>▶ A variance in mounting height.</li> <li>▶ Normal manufacturing and component tolerances.</li> <li>▶ Variances in field measurements, procedures and conditions.</li> <li>▶ Use of spacers for mounting.</li> </ul>		
Output Contacts Rating	Non-polarized, No voltage, Semi-conductor relay output 30 VAC/50VDC, 0.1A (Resistance Load) N.C. or N.C.		
	<table border="1"> <tr> <td>When Set to N.O.</td> <td> <ul style="list-style-type: none"> <li>▶ No Detection “Open”</li> <li>▶ Detection “Closed”</li> <li>▶ Power Failure “Open”</li> <li>▶ Sensor Malfunction “Closed”</li> </ul> </td> </tr> </table>	When Set to N.O.	<ul style="list-style-type: none"> <li>▶ No Detection “Open”</li> <li>▶ Detection “Closed”</li> <li>▶ Power Failure “Open”</li> <li>▶ Sensor Malfunction “Closed”</li> </ul>
When Set to N.O.	<ul style="list-style-type: none"> <li>▶ No Detection “Open”</li> <li>▶ Detection “Closed”</li> <li>▶ Power Failure “Open”</li> <li>▶ Sensor Malfunction “Closed”</li> </ul>		

Specification	Description
Mounting Height	78 inches to 118 inches (2.0m to 3.0m)
Weight	Approximately 10 ounces (285g)
Color	Black Cover or Silver Cover
Full Color LED	► Displays operating status
Angled Spacer	The Angled Spacer is an option that is sold separately. To do so, please call Customer Service at 1-888-679-3319. ► For Slide doors only ► For increased depth range.
Adjustable Detection Area	► Depth ► Width
ECO Mode	Closes door earlier for a pedestrians moving away from door.

**Table 2** Electrical Wiring

Item	Description
Input Voltage	12-24 Volts AC or DC
Power Consumption	3VA or less @ 24VAC
	80mA or less @ 24VDC
	150mA or less @ 12VDC
Output	► Non-polarized semi-conductor relay, N.O. or N.C. ► Max. 100mA @ 30VAC/50VDC

Make sure total power consumption of all Sensors does not exceed the capability of the door control or power supply.  
Exceeding the rated output may result in malfunction or breakdown.

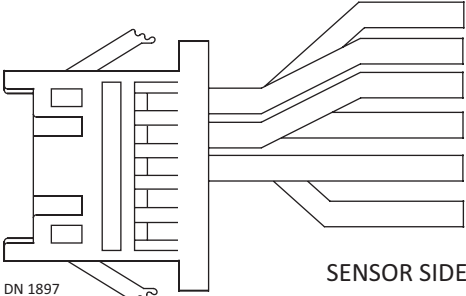
 <p>DN 1897</p>	<b>Supply</b>		<b>Wire</b>	
	Power	Brown: + / ~		
		Red: - / ~		
	Output	Black		
		Green		
Input	Gray: INPUT +			
	Yellow: INPUT -			

## CHAPTER 4: PRESENCE DETECTION AREA

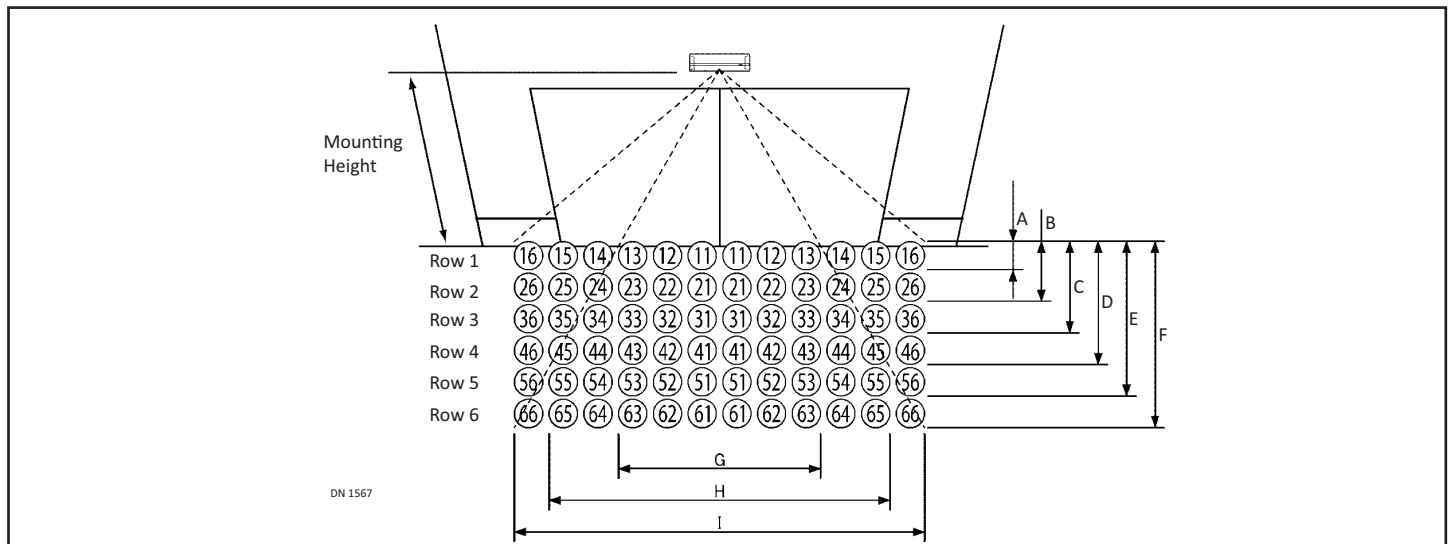

The Sensor is used to detect changes of multiple near-infrared rays that beam from the Sensor down to various points on the floor. These various points reflect the near-infrared rays to form a grid in the shape of a square. To more accurately monitor a Presence Detection Area, the grid is broken into invisible rows (Depth), and columns (Width).

**Notice: Width and depth of Presence Detection Area must comply with ANSI Standards.**

**Table 3** Detection Area Size

Without Angled Spacer (Area Adjuster set at 0 degrees)					
Mounting Height		78" (2.0m)	87" (2.2m)	98" (2.5m)	118" (3.0m)
Depth	A	4" (100mm)	4" (100mm)	5" (120mm)	6" (150mm)
	B	15" (390mm)	17" (430mm)	19" (480mm)	23" (580mm)
	C	26" (650mm)	28" (720mm)	32" (820mm)	39" (980mm)
	D	38" (960mm)	41" (1,050mm)	47" (1,200mm)	57" (1,440mm)
	E	51" (1,300mm)	56" (1,430mm)	64" (1,620mm)	77" (1,950mm)
	F	63" (1,600mm)	72" (1,820mm)	82" (2,070mm)	98" (2,490mm)
Width	G	48" (1,220mm)	53" (1,350mm)	60" (1,530mm)	72" (1,840mm)
	H	83" (2,100mm)	91" (2,320mm)	104" (2,630mm)	124" (3,160mm)
	I	104" (2,640mm)	114" (2,900mm)	130" (3,300mm)	156" (3,960mm)
With Angled Spacer (Area Adjuster set at 0 degrees)					
Mounting Height		78" (2.0m)	87" (2.2m)	98" (2.5m)	118" (3.0m)
Depth	A	4" (100mm)	4" (100mm)	5" (120mm)	6" (150mm)
	B	15" (390mm)	17" (430mm)	19" (490mm)	23" (590mm)
	C	26" (670mm)	29" (740mm)	33" (840mm)	40" (1,010mm)
	D	38" (1000mm)	43" (1,100mm)	49" (1,250mm)	59" (1,500mm)
	E	54" (1,370mm)	59" (1,510mm)	68" (1,720mm)	81" (2,060mm)
	F	71" (1,790mm)	78" (1,970mm)	88" (2,240mm)	106" (2,680mm)
Width	G	48" (1,230mm)	53" (1,350mm)	61" (1,540mm)	79" (1,850mm)
	H	83" (2,110mm)	91" (2,320mm)	104" (2,640mm)	125" (3,170mm)
	I	104" (2,650mm)	114" (2,920mm)	131" (3,320mm)	157" (3,980mm)

#### SECTION 4.1: Cause for Malfunctions

Illustrated examples shown below, are meant to display some (not all) causes for malfunction to occur within the Presence Detection Area.

**Table 4** Common Causes for Malfunctions

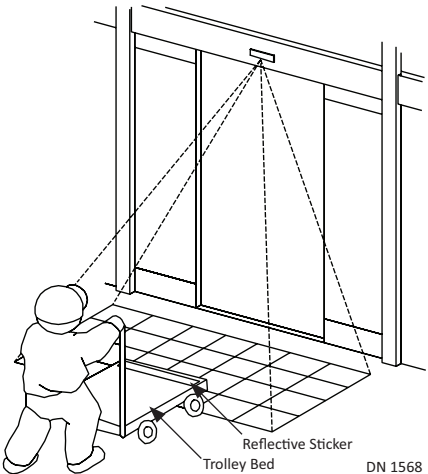
<p>The bed of a trolley:</p> <ul style="list-style-type: none"> <li>▶ Is too low to the floor</li> <li>▶ Surface of cart or trolley is not reflective enough to be detected. (Reflective tape or stickers can help)</li> </ul>	
--	---

Sensor is exposed to:

- ▶ Steam
- ▶ Exhaust fume
- ▶ Insects
- ▶ Heavy rain
- ▶ Heavy snow

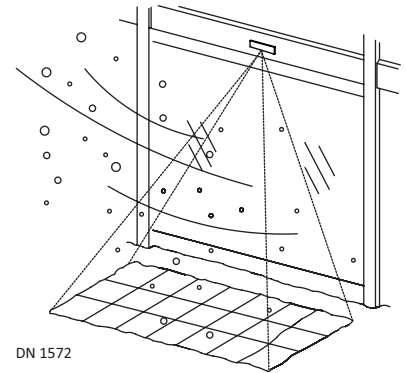

Pool of water located within Presence Detection Area

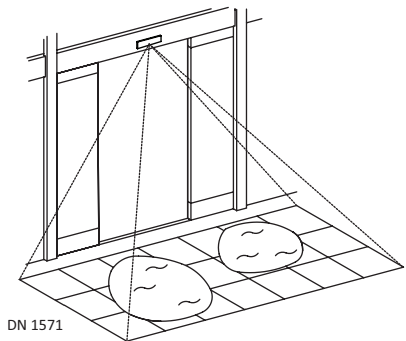

An object placed within the Presence Detection Area that may be moving within the detection area (like due to wind).

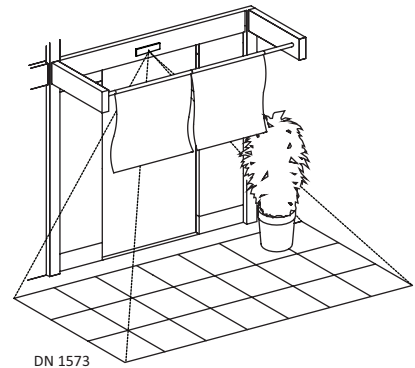

Multiple Sensors installed close to each other, or facing each other

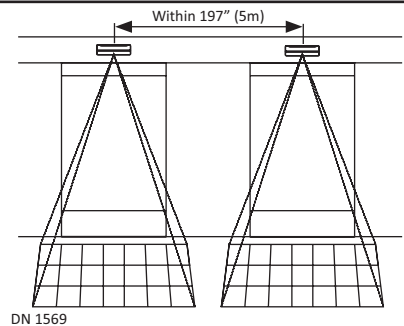

Presence Detection Area is flooded with:

- ▶ Strong direct Sunlight
- ▶ Sunlight reflecting from floor (such as marble, or aluminum floors)
- ▶ Strong direct artificial light
- ▶ Artificial light reflecting from floor (such as marble, or aluminum floors)
- ▶ Lighting fixtures placed too close to the Sensor

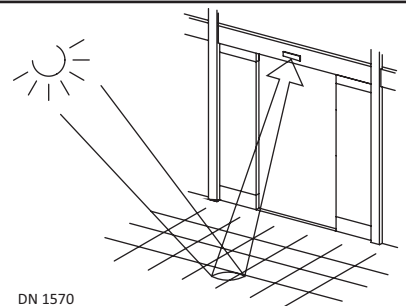

## CHAPTER 5: INSTALL THE ACUSENSOR M

### WARNING

Shut OFF the installation site, branch Circuit Breaker. Failure to do so may result in serious personal or fatal injury. When uncertain whether power supply is disconnected, always verify using a voltmeter.

### WARNING

All high voltage electrical connections must be made by licensed electricians according to National and Local electrical codes/regulations.

### CAUTION

Permanent wiring shall be employed as required by local codes.

### CAUTION

Keep all Incoming 120 VAC wiring separate from low voltage wiring within Header. 120 VAC Power wires must be routed (separate from other wiring) located near the top of inside Header.

### SECTION 5.1: Secure Sensor to Header

1. Turn OFF power.
2. Remove Cover from Sensor.
3. Remove (2) #10 x 1/2 inch Phillips Panhead screws from the cradles.

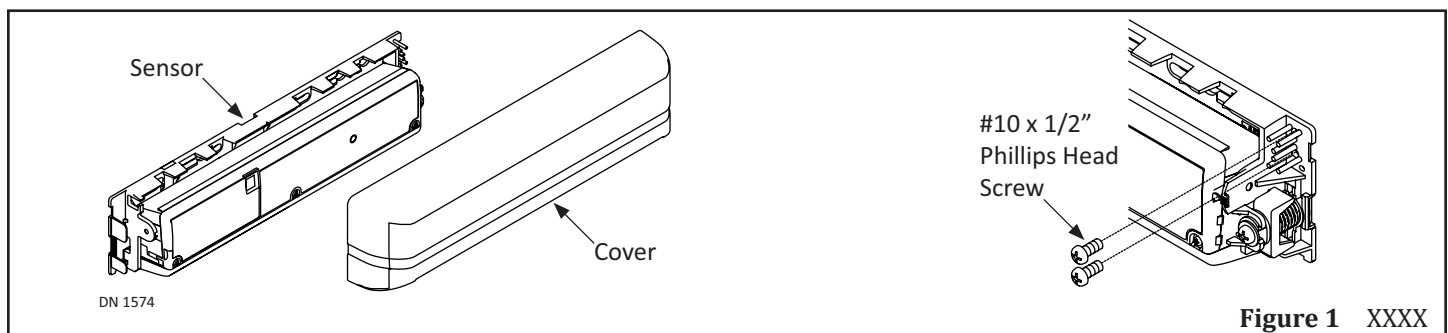

Figure 1 XXXX

4. Line up the predrilled screw holes located on the Mounting Plate with predrilled screw holes on the Header Cover.
5. Secure the Sensor to the Header Cover with (2) #10 x 1/2 inch Phillips Panhead screws.

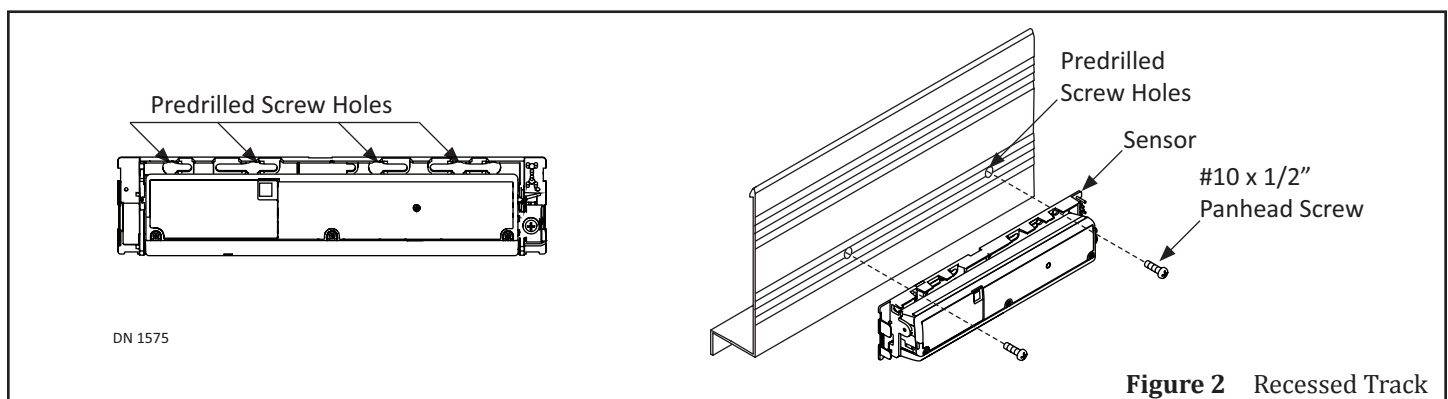

Figure 2 Recessed Track

### SECTION 5.2: Install the Angled Spacer (Sold Separately)

*Note: The Angled Spacer is an option that is sold separately. To do so, please call Customer Service at 1-888-679-3319.*

1. Turn OFF power.
2. Remove Cover from Sensor.
3. Seat the Sensor inside the Angled Spacer.
  - a. The flat side of Angled Spacer must butt up against the Header Cover.
4. Align the predrilled screw holes located on the Mounting Plate with the predrilled screw holes located on the Angled Spacer.
5. Secure the Sensor to the Header Cover with (2) #10 x 5/8 inch Phillips Panhead screws (supplied with the Angled Sensor Kit).
  - a. Do not use (2) #10 x 1/2" Phillips Panhead screws that were supplied with the Acusensor M kit.



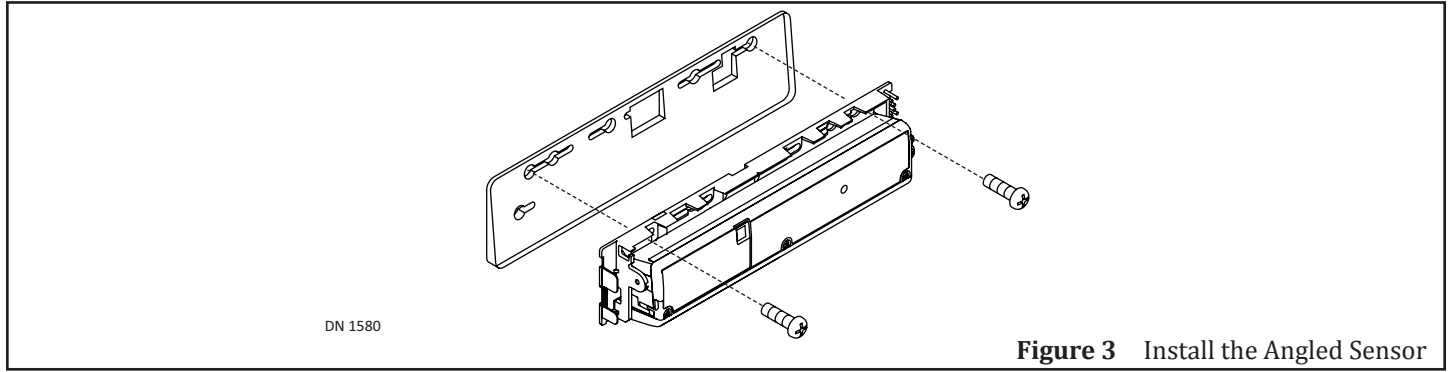

## CHAPTER 6: WIRE THE ACUSENSOR M

### SECTION 6.1: Wire Swing Door with Monitoring (Opus Control)

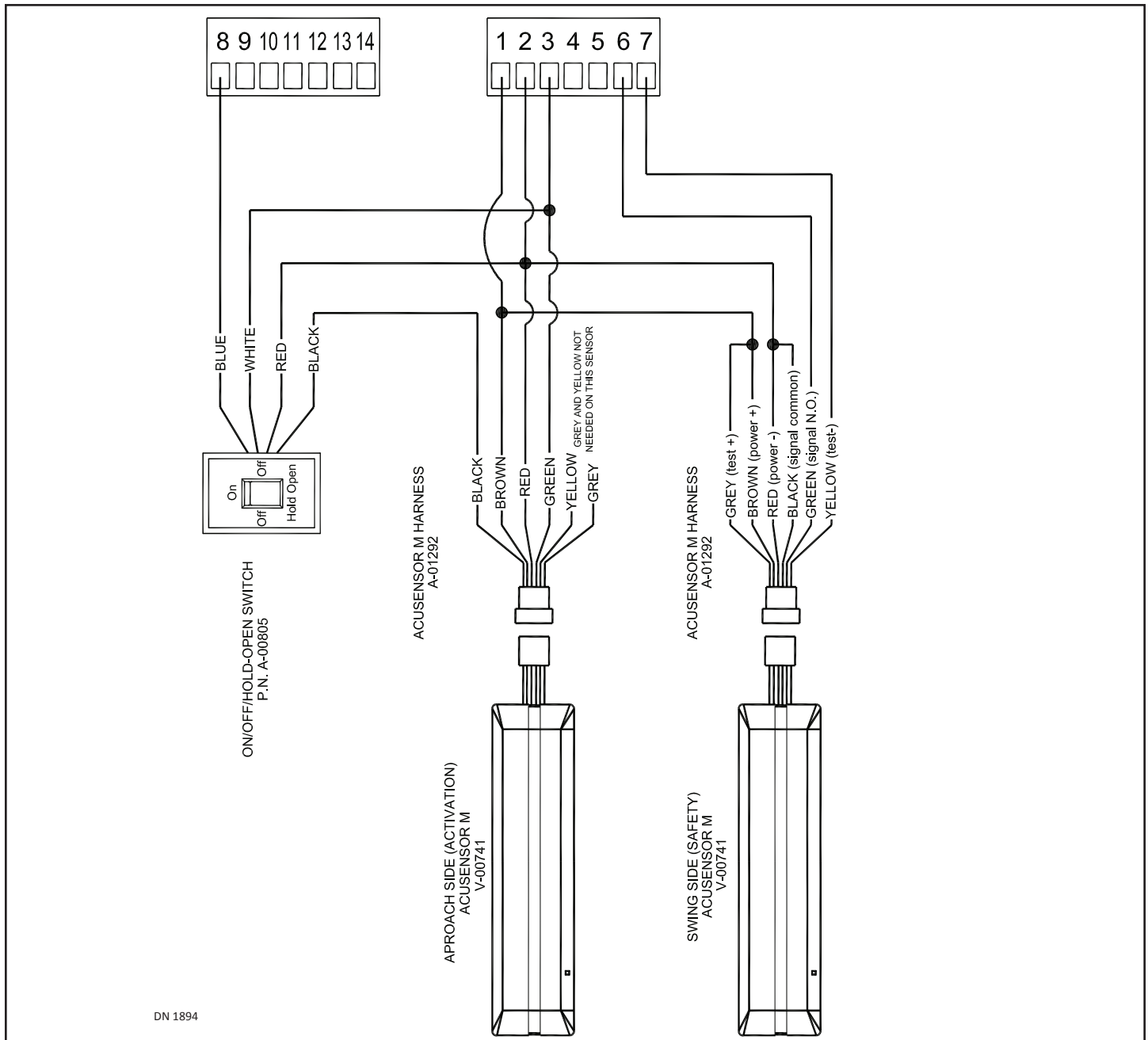

**SECTION 6.2: Wire Fold Door with Monitoring (Opus Control)**

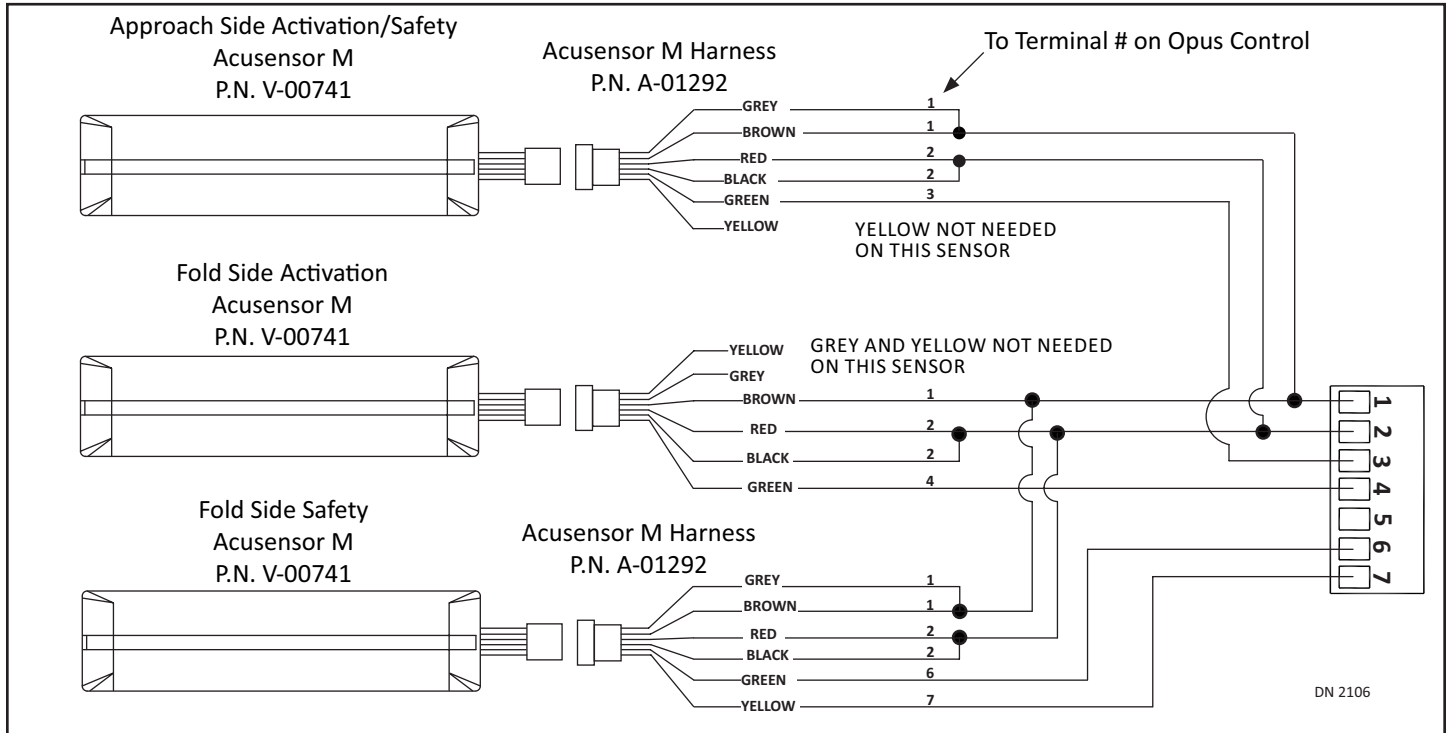

**SECTION 6.3: Wire Slide Door with Monitoring (U30 Control)**

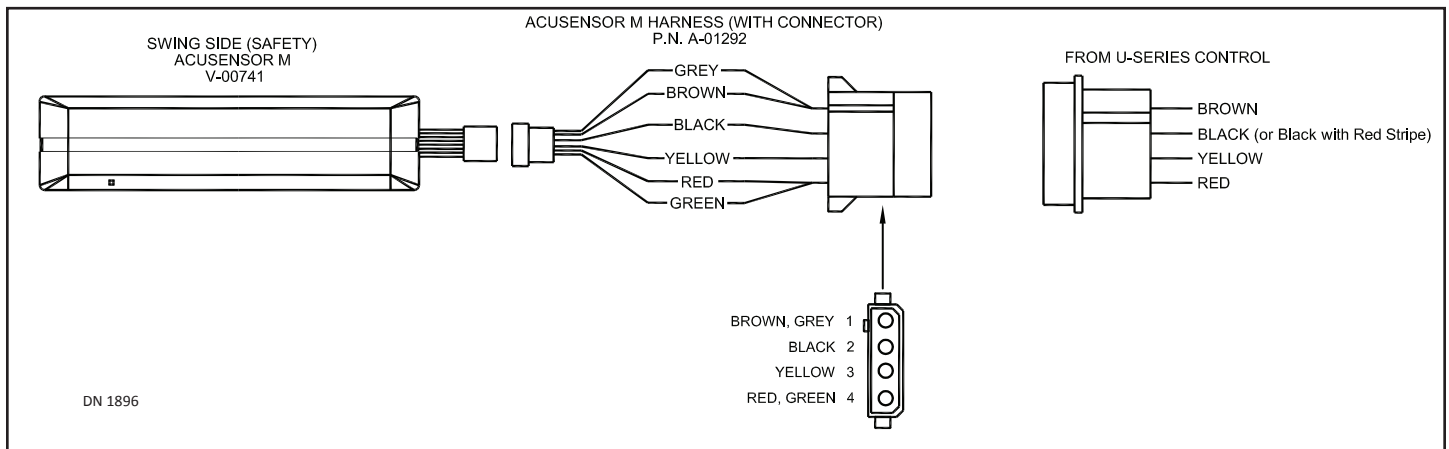

**CHAPTER 7: SWITCH SETTINGS 1-8**

1. Turn OFF power. Lift the reusable protection flap located on the Left hand side of Acusensor M.

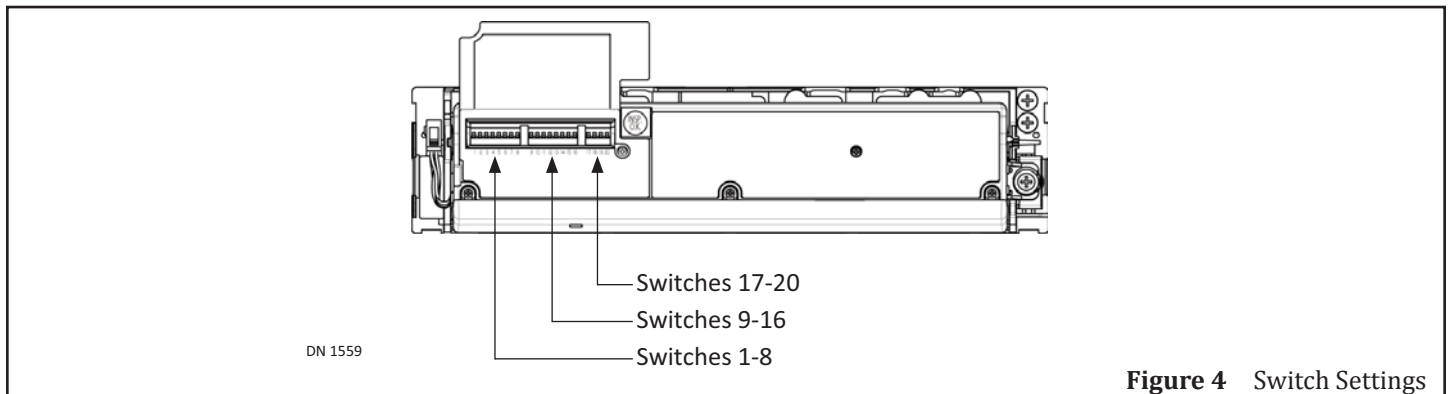

**Figure 4** Switch Settings

- Go Underneath the flap. Locate three groups of Switches. The backside of Flap shows a diagram for how to set switches 1 thru 8.

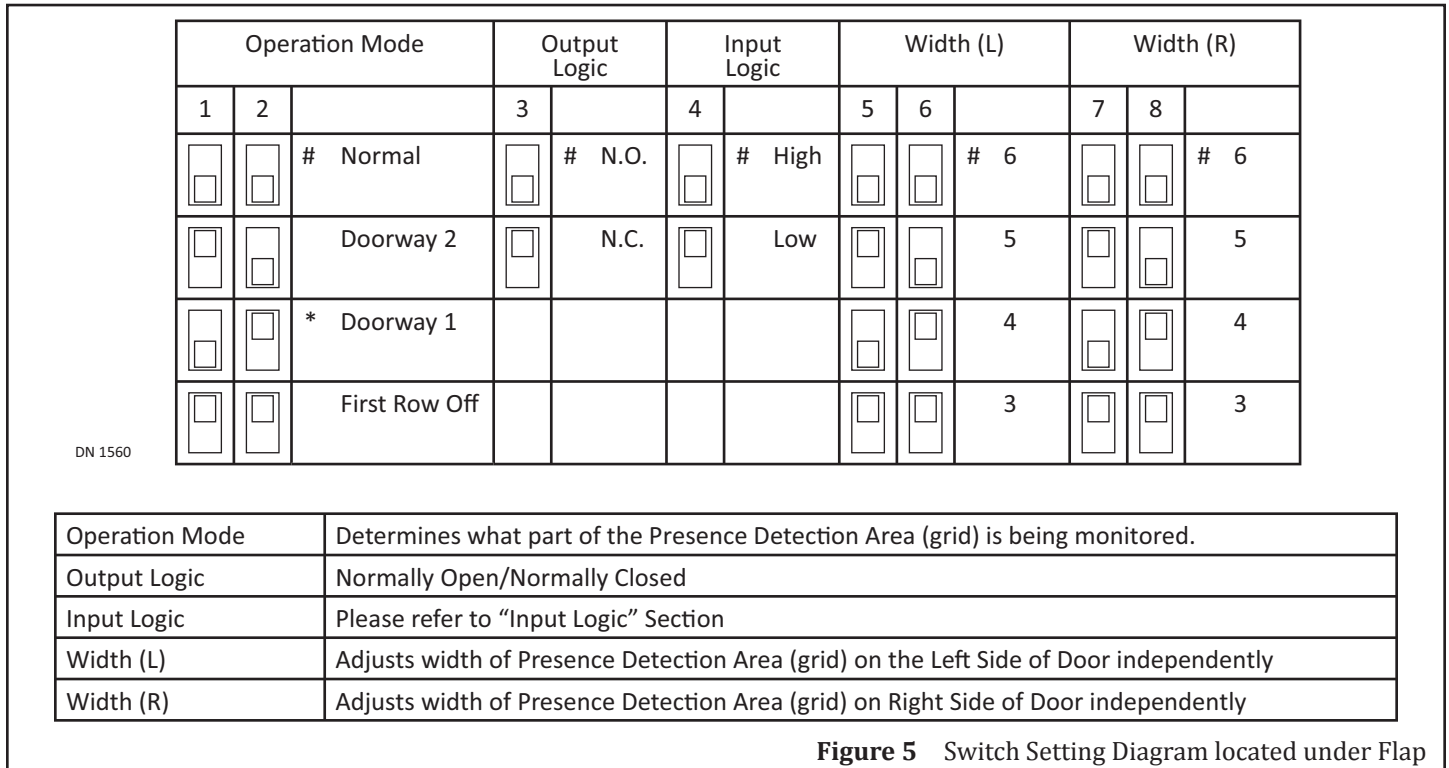

**SECTION 7.1: Operation Mode (Switches 1 and 2)**







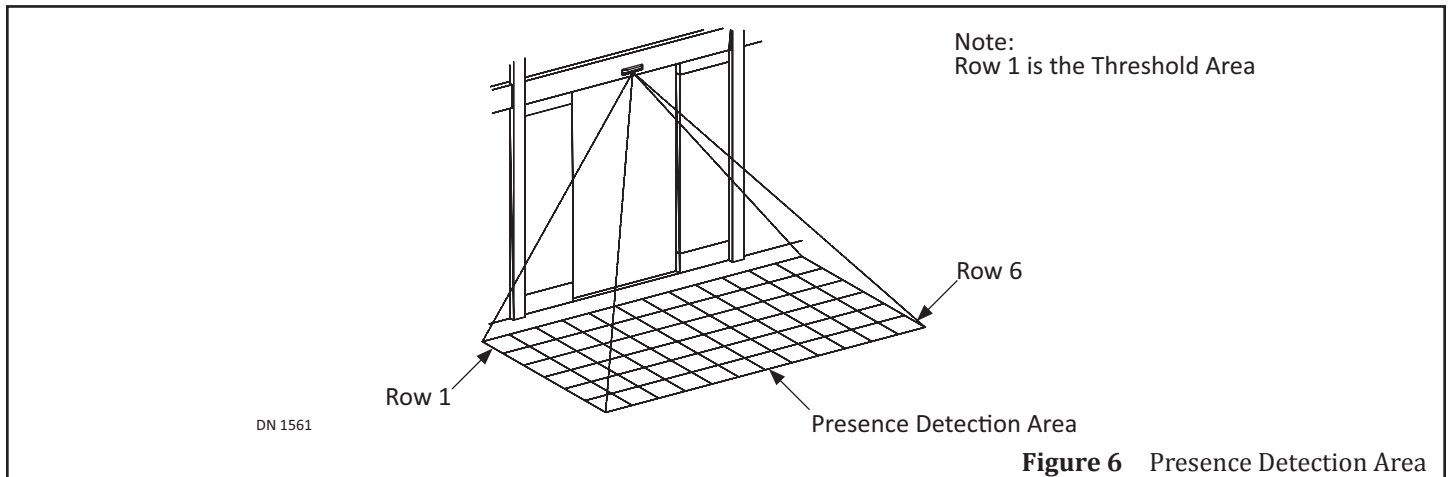

*Note: Labeled as Operation Mode but is actually a Monitoring Operation Mode.*

Monitoring is an added layer of communication between the control and the sensor. The control will send a signal to the sensor. The sensor performs a self-diagnostic test, then sends a signal back to the control confirming proper operation.

The Monitoring Operation Mode (set by dip switches 1 and 2) determines which rows of presence detection are active and which are applied to the monitoring function. Active rows are not the same as rows that are monitored. Rows can be active (able to tell the control to open the door) but not be applied to the Monitoring function.



**Table 5** Standard Monitoring Operation Modes













Operation Mode		Door Type	Presence Detection Area	Monitor Description	
1	2				
		Normal	Slide	Depth Row 1 and 2	Doorway monitoring is not applied for Depth Row 3 thru 6
		Doorway 2	► Swing ► Fold	Depth Row 1 thru 6	► Doorway monitoring works for all Depth Rows ► Fold, and Swing doors only
		Doorway 1	Slide	Depth Row 2 and 3	► Doorway monitoring works for Depth Row 1 ► Doorway monitoring does not work for Depth Row 2 thru 6
		1st Row OFF	Slide	Depth Row 2 and 3	► Depth Row 1 becomes inactive ► Doorway monitoring is not applied for Depth Row 2 thru 6

**SECTION 7.2: Output Logic (Switch 3)**

*Note:* Ensure both the Acusensor M and the Control is set for N.O. or N.C.

When a presence is detected within a monitored area, the control automatically sends a pulse to Input Logic. Output Logic automatically responds by opening the door.

**Table 6** Output Status



Output Logic		Definition	Stand-by	Detecting	Action	Test Reply (Good)	Test Reply (Error)	Power OFF
3								
	N.O.	Normally Open			Circuit closes Door opens			
	N.C.	Normally Closed			Circuit opens Door opens			

In the event a Self Diagnostic Error occurs, the door will not open. Instead the Sensor LED will illuminate a blinking Red Light (1Hz) indicating an Error.

**SECTION 7.3: Input Logic (Switch 4)**

*Note:* Ensure both the Acusensor M and the Control is set for N.O. or N.C.

**Table 7** High Setting vs Low Setting

Input Logic		Description	
4			
	High	+input	Connects to +voltage
		- input	Connects to Output, regardless of Switch 4 Setting.
		► U30 FUNCTION (6) setting should be No ► Opus setting should be "Sensor Monitoring N.O. (Normally Open)"	
	Low	+input	Connects to +voltage
		- input	Connects to Output, regardless of Switch 4 Setting.
		► U30 FUNCTION (6) setting should be "Yes". ► Opus setting should be "Sensor Monitoring N.C. (Normally Closed)"	

**SECTION 7.4: Width Setting (Switches 5 thru 8)**

Note: On swing and fold doors, set width pattern as narrow as needed to avoid detection of the door in the open position.

**Table 8** Presence Detection Area

Width (L)			Width Area Diagram			Width (R)		
5	6		● = Active Area Left Side	○ = Inactive Area	● = Active Area Right Side	7	8	
		6						6
		5						5
		4						4
		3						3

**CHAPTER 8: SWITCH SETTINGS 9-20**

#	Default Setting	IP Mode	Interference Protection														
9	10	11	12	13	14	15	16	17	18	19	20						
#6			2			#30s		#Normal			#Normal			#H			#A
5			5-6eco			15s		Special			Anti-Vibration			M			B
4			4-6eco			60s					Anti-Snow I			L			C
3			Area Check			300s					Anti-Snow II			SH			D
Depth		Adjusts depth of Presence Detection Area (grid)															
Learn Time		The amount of time it takes for the sensor to learn the area, or relearn if a normally stationary object is moved. ANSI requires minimum 30sec.															
Anti-Noise		Helps prevent false detection caused by electrical noise or nearby light sources.															
Anti-Environment		Helps prevent false detection caused by vibration, insects, snow.															
Sensitivity		Adjust signal strength for detecting moving pedestrians or objects. Example: For slow moving pedestrians or objects, sensitivity option should be on Medium or High.															
IP Mode		Helps prevent interference caused by sensors near each other.															

1. Turn OFF power.
2. Lift the reusable protection flap, located on the Left hand side of Acusensor M to locate three groups of Switches.
3. Go to the middle of the Acusensor M to locate a diagram for how to set switches 9 thru 20. Please see Figure 7.

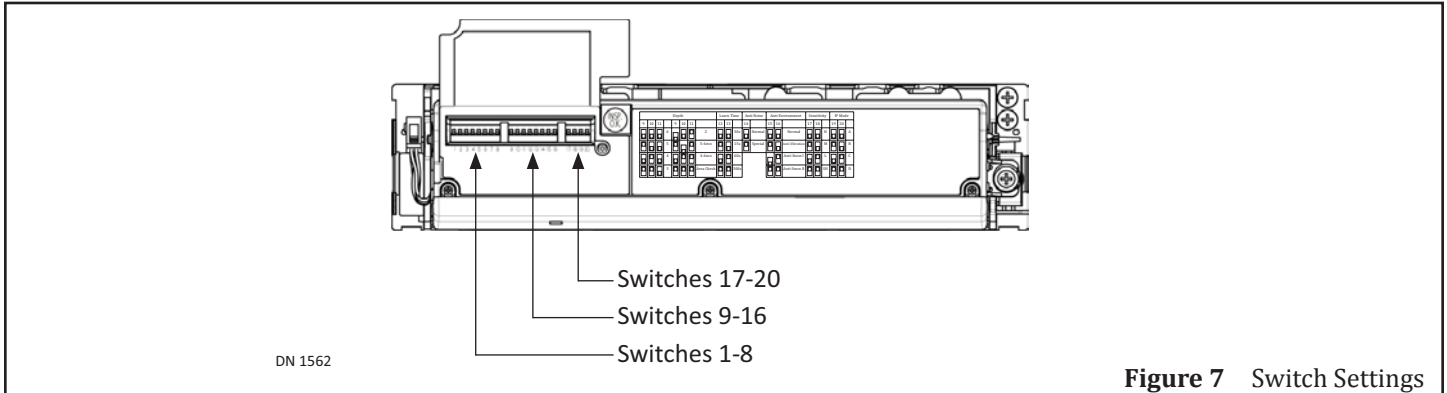

**Figure 7** Switch Settings

**SECTION 8.1: Depth Setting (Switches 9 thru 11)**

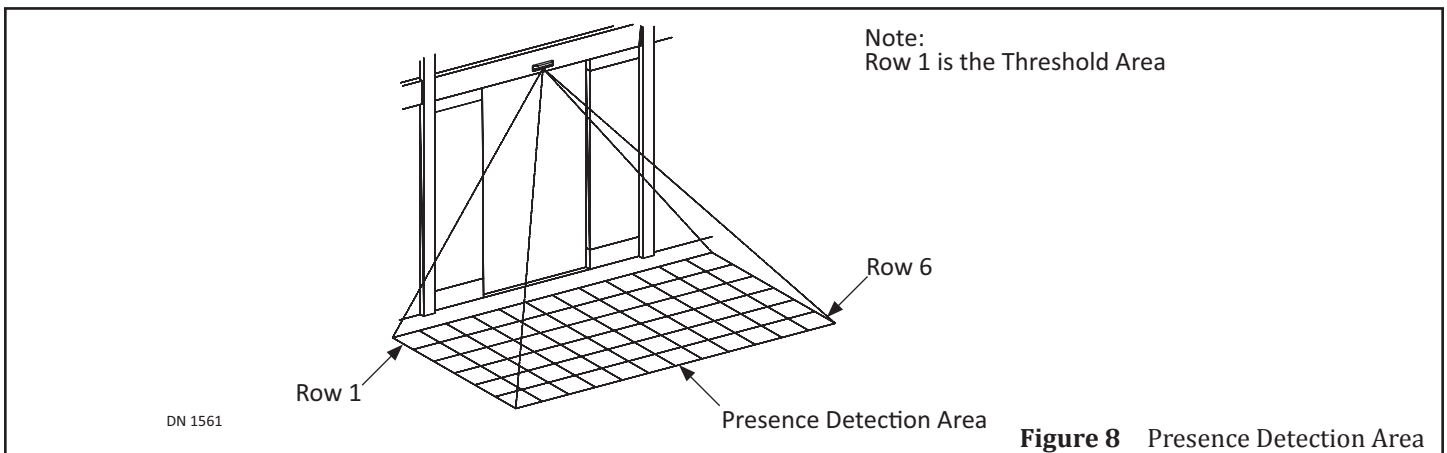

**Figure 8** Presence Detection Area

**Table 9** Depth for Operation Mode: Normal, Doorway 1, and 1st Row OFF

Depth				Detection Area Diagram					Detection Area Diagram
9	10	11	9		10	11			
			6					2	
			5					5-6 ECO	
			4					4-6 ECO	
			3					*Area Check	

●	Operation Mode	Normal	This row is active, but not applied to the monitoring function.
		Doorway 1	This row is active, and is applied to the monitoring function.
		1st Row OFF	Inactive
⊗	ECO Mode	<ul style="list-style-type: none"> <li>▶ Directional presence detection. For detailed information please refer to Subsection Table 3.</li> <li>▶ Same Depth Rows are Active.</li> </ul>	
●	No Monitoring	<ul style="list-style-type: none"> <li>▶ These rows are active, but not applied to the monitoring function.</li> <li>▶ Depth Rows Active.</li> </ul>	
○	Inactive	Depth Rows are not Active.	
*	Used for adjusting detection area depth and confirming test command input, during installation only. For detailed information please refer to Subsection SECTION 7.3.		

**Table 10** Depth for Operation Mode: Doorway 2

Depth				Detection Area Diagram				Detection Area Diagram			
9	10	11		9	10	11		9	10	11	
			6					2			
			5					N/A	ECO Mode does not work well with Swing and Fold doors.		
			4					N/A	ECO Mode does not work well with Swing and Fold doors.		
			3					Area Check			
●	Operation Mode	<ul style="list-style-type: none"> <li>▶ Doorway monitoring works</li> <li>▶ Depth Rows are Active</li> </ul>		●	<ul style="list-style-type: none"> <li>▶ Depth Rows will never be Active</li> <li>▶ If Row 1 is Active, mis-detection will occur on Swing Doors and Fold Doors</li> </ul>						
○	Inactive	Depth Rows are not Active.									

**8.1.1 ECO Mode**

**CAUTION** If mounting height for Sensor is low, movement can easily be detected within multiple rows at the same time. Because of this, the ECO Mode may not operate correctly.

Note: ECO Mode is an acronym for Ecological Friendly Mode, also known as Directional Sensing.

Note: ECO Mode is not used for Doorway 2 operation.

ECO Mode is a function that decides whether movement is coming toward the door, or away from door (directional sensing). If the Sensor decides movement is going away from door, the High or Low feature will determine how far the object gets before the door is allowed to close.

Mode	Depth Rows	Description
Low	5 and 6	Output stops when and object is detected moving away through rows 5 to 6.
	1 thru 4	Output maintains when and object is detected in rows 4 to 1.
High	4, 5, and 6	Output stops when and object is detected moving away through rows 4 to 6.
	1 thru 3	Output maintains when and object is detected in rows 3 to 1.

### 8.1.2 Area Check Mode

**Attention:** Area Check Mode is utilized during installation of the Acusensor M - only. Once correctly installed, the Depth Setting must be set to any Setting other than Area Check.

Area Check Mode is used for adjusting the depth of a detection area, and confirm test command input.

An unique LED color is assigned to each Depth Row (1 thru 6). When the installer selects a Depth Row, the Sensor will illuminate each assigned LED color.

If multiple Depth Rows are detected at the same time the Sensor's LED will illuminate the color assigned to the Depth Row closest to the face of Door.

**Table 11** Assigned LED Colors

Row	LED	
1	Red	When Operation Mode is set to (Normal) or (Doorway 2)
	No Light	When Operation Mode is set to (Doorway 1) or (1st Row)
2	Pale Blue	
3	Yellow	
4	Blue	
5	Green	
6	Purple	

While in Area Check Mode, and every time the door opens, the Control will send a Test Command Input Signal to the Sensor. Before the door starts to open, the Sensor LED will illuminate a blinking White light (4) times (10Hz), indicating communication between the Control and Sensor is normal.

While in Area Check Mode, the ECO Mode will become inactive, and Learn Time becomes 5 seconds.

**Table 12** LED Operating Status

Sensor Status	LED	Sensor Operating Order
Recognized Test Command Input	White Light blinks (4) times	1
Detected Depth Row 1 thru 6	Assigned LED color	2
Stand-by	No Light	3

### 8.1.3 Depth Row Detection LED Lights

During normal operation, when a Depth Row is in Detection, the Sensor's LED will illuminate an assigned color.

If multiple Depth Rows are detected at the same time the Sensor's LED will illuminate the color assigned to the Depth Row closest to the face of Door.

**Table 13** Assigned LED Colors

Operation Mode	Depth Row 1	Depth Row 2	Depth Row 3	Depth Row 4	Depth Row 5	Depth Row 6
Normal	RED		Orange			
Doorway I	Purple	Red		Orange		
Doorway II	Red					
1st Row OFF	N/A	Red		Orange		



**SECTION 8.2: Learn Time (Switches 12 and 13)****WARNING**

In the event a moving pedestrian decidedly stands still within the Presence Detection Area for a time longer than the “Learn Time”, the door may close and cause *some* probability of severe injury or entrapment.

**WARNING**

After Power is turned ON, do not enter the Presence Detection Area for (1) minute.

**Notice:** Set Learn Time to 30 seconds or longer to comply with ANSI Standard.

Learn Time is when the Sensor learns that a stationary object is part of the area, and learns to ignore that object in order for the door to close. Learn Time differs due to the Switch Setting for Operation Mode and Switch Setting for Depth Row.

**Table 14** Learn Time

Operation Mode	Row 1	Row 2	Row 3	Row 4	Row 5	Row 6
Normal	Set: 15s, 30s, 60s, or 300s		5 seconds (fixed)			
Doorway 1	Set: 15s, 30s, 60s, or 300s			5 seconds (fixed)		
Doorway 2	Set: 15s, 30s, 60s, or 300s					
1st Row OFF	Inactive	Set: 15s, 30s, 60s, or 300s		5 seconds (fixed)		



**SECTION 8.3: Anti-Noise (Switch 14)**

**Attention:** If the Switch (Special) is selected, presence detection may be delayed. Be sure to confirm presence detection reaction by walking within the presence detection area, at a normal pace.

**Attention:** In the event the Anti Noise setting is not effective, selecting a different IP setting may help.

*Note:* Anti Noise helps prevent false detection caused by electrical noise or nearby light sources.









**Table 15** Anti-Noise

Anti-Noise		Description
14		
	Normal	Anti Noise is OFF.
	Special	Use when a malfunction occurs due to a lighting fixture, or an electro magnetic noise.

**SECTION 8.4: Anti-Environment (Switches 15 and 16)**

**Attention:** Using Anti-Snow II setting narrows down the Detection Area. If the Sensor mounting height is 118 inches (3.0m), the presence detection area may become extremely narrow. Confirm the presence detection reaction by walking within the presence detection area at a normal pace.

**Table 16** Anti-Environment









Anti-Environment		Vibration	* Mirror	Snow	Insect	Note	
15	16						
		Normal	Inactive	Inactive	Inactive	N/A	
		Anti-Vibration	Active	Inactive	Inactive	Use when Sensor malfunctions due to door vibration during operation	
		Anti-Snow I	Inactive	Inactive	Active	Response time may slow down	
		Anti-Snow II	Active	Active	* Active	** Active	Select if no improvement is seen using Anti-Vibration and/or Anti-Snow I
							* Response time may slow down
							** Detection Area narrows down
* Mirror is when Sensors are facing each other at a close distance.							

## SECTION 8.5: Sensitivity (Switches 17 and 18)

**Attention:** Be sure to confirm presence detection reaction by walking within the presence detection area, at a normal pace.

*Note:* The Sensitivity Mode may be activated for reasons such as color/material of the floor or clothes.

**Table 17** Sensitivity

Sensitivity		Mounting Height
17	18	
		H (High) <ul style="list-style-type: none"> <li>▶ 98" thru 118" (2.5m thru 3.0m)</li> <li>▶ Recommended Switch Setting for above mounting height</li> </ul>
		M (Medium) <ul style="list-style-type: none"> <li>▶ 79" thru 98" (2.0m thru 2.5m)</li> <li>▶ Recommended Switch Setting for above mounting height</li> </ul>
		L (Low) <ul style="list-style-type: none"> <li>▶ 79" thru 98" (2.0m thru 2.5m)</li> <li>▶ Use if sensitivity is too HIGH with Switch Setting (M)</li> </ul>
		SH (Super High) <ul style="list-style-type: none"> <li>▶ 98" thru 118" (2.5m thru 3.0m)</li> <li>▶ Use if sensitivity is too LOW with Switch Setting (H)</li> </ul>

## SECTION 8.6: IP Mode (Switches 19 and 20)









**Attention:** DO NOT use Acusensor M with Acusensor 3 within the same Presence Detection Area. IP Mode may not work properly. Replace Acusensor 3 Sensors with Acusensor M Sensors.

**Attention:** Interior side Sensor and exterior side Sensor must have different IP mode setting.

IP Mode is utilized when Sensors are placed within the same Area and/or when Sensors are facing each other. This is true for multiple Acusensor M Sensors and/or older versions of the Acusensor, Acuvision, and/or Acumotion sensors.

To prevent Sensor Malfunction, the IP Mode Setting must be different from that on each other sensor.

**Table 18** IP Mode

IP Mode		Description
19	20	
		A Default for the Acusensor M
		B Suggested IP Mode for 2nd Sensor
		C Suggested IP Mode for 3rd Sensor
		D Suggested IP Mode for 4th Sensor

## CHAPTER 9: AREA ADJUSTER

The Area Adjuster is a Phillips Head screw that the installer turns to angle the Sensor:

- ▶ Counter Clockwise to adjust the Detection Area Pattern farther out.
- ▶ Clockwise to adjust the Detection Area Pattern farther in.

An Angled Spacer (sold separately) can be used to provide a Presence Detection Area outside of normal Depth.

1. Turn OFF power.
2. Go to Area Adjuster located on the Right hand side of Acusensor M.

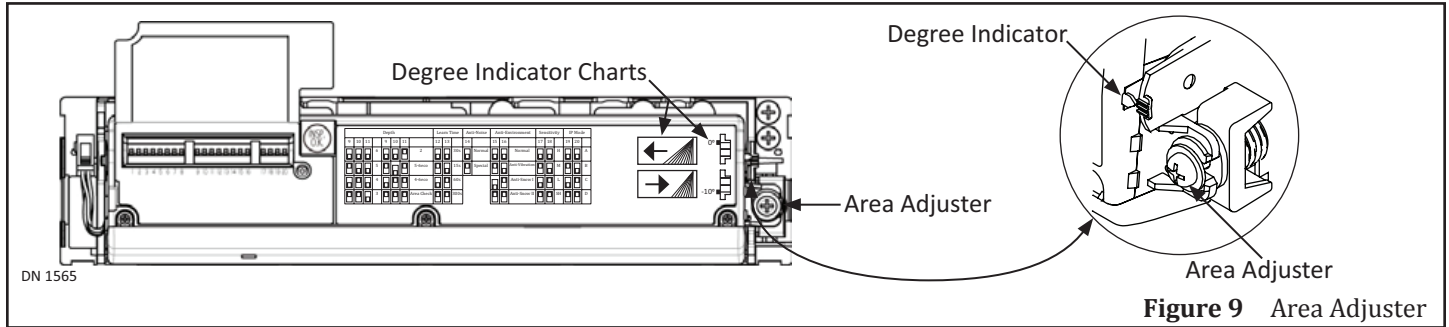

**Figure 9** Area Adjuster

3. Turn the Area Adjuster until the preferred Depth is achieved.
  - a. One half turn of the Area Adjuster:
    - ▶ Without an Angled Spacer is almost equivalent to (1) degree.
      - (1) degree = 1.57 inches (40mm) if the Sensor mounting height is 87 inches (2.2m)
    - ▶ Adding the Angled spacer (sold separately) adds an additional 5 degrees.
  - b. As the phillips head screw is turned, the Degree Indicator Lever will move from (0 to -10 degrees).

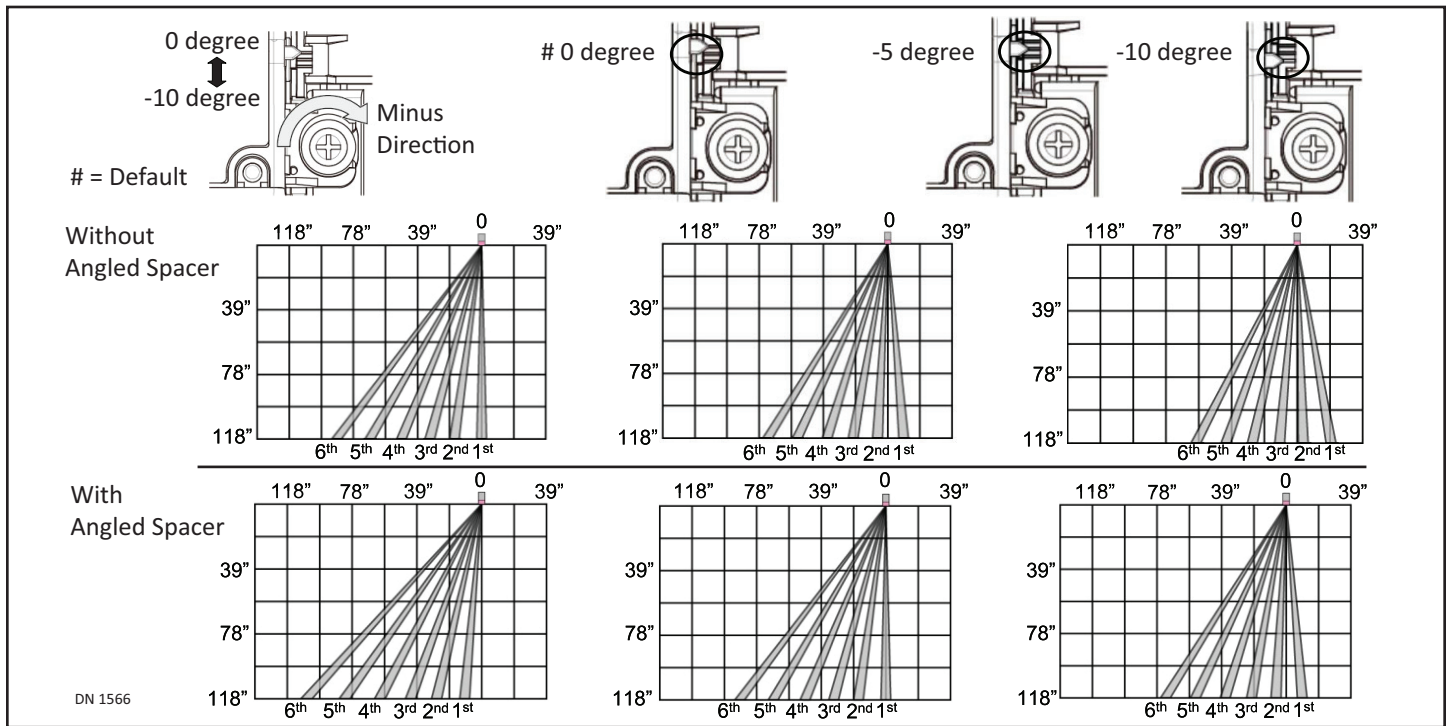

**SECTION 9.1: Adjust Presence Detection Area**

**9.1.1: Normal, and Doorway 2; Operation Mode**

1. Flip Switches 9, 10, and 11 UP.
2. Turn ON Power. Turn the Area Adjuster until Depth Row (1) can be detected within (5) inches from the face of Door.
  - a. To do so, walk within the presence detection area until the LED illuminates a Red light.
  - b. The Red light indicates that Depth Row (1) is detecting.

**9.1.2: Doorway 1, and 1st Row OFF; Operation Mode**

1. Flip Switches 9, 10, and 11 UP.
2. Turn ON Power. Locate the center of Depth Row (1 and 2).
  1. To do so, walk within the presence detection area until the LED illuminates a Pale Blue light.
    - a. The Pale Blue light indicates that Depth Row (2) was detected.

2. Turn the Area Adjuster until Depth Row (2) can be detected within (5) inches from face of Door.
  - a. Depth Row (2) should not become part of the Threshold.

**9.1.3: Test Angle Adjustment**

- ▶ Detection must occur to within (5) inches of the face of the door.
- ▶ The pattern needs to be moved out if the door itself is being detected.
- ▶ The pattern needs to be moved in if there is a loss of detection at any point greater that (5) inches from the face of the door.

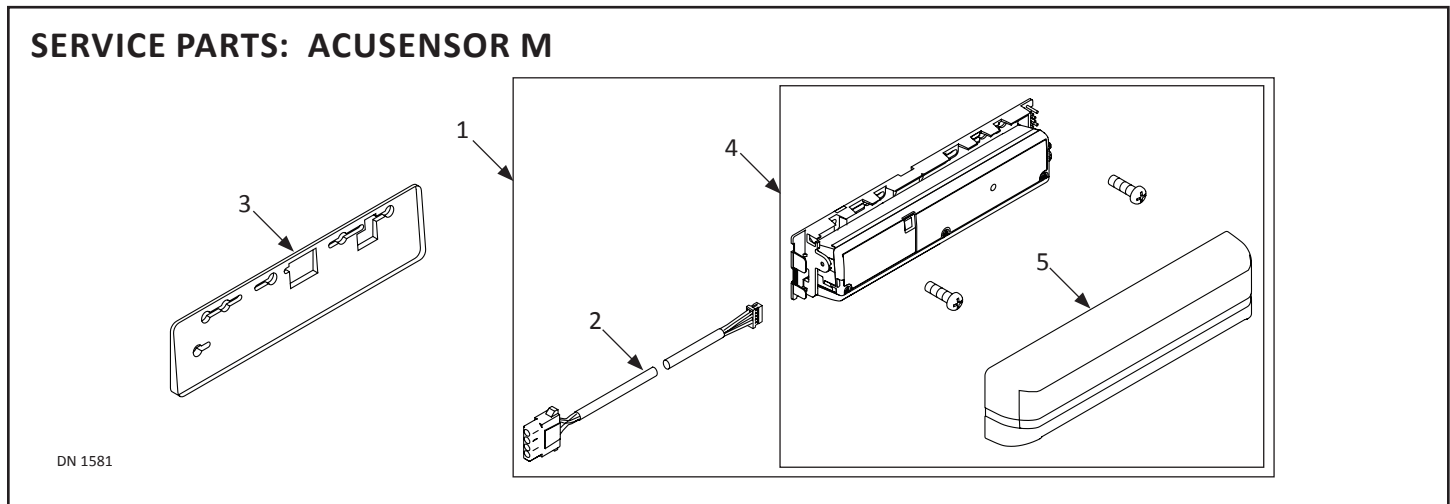

Acusensor M				
Item	Part	Finish/Sizes/Notes	Part	Description
1	A-01306		KIT, ACUSENSOR M	
2	A-01292		HARNES, ACUSENSOR M	
3	V-00742		SPACER, ANGLED - ACUSENSOR M	
4	V-00741		SENSOR, ACUSENSOR M	
5	V-00744		COVER, ACUSENSOR M - BLACK	



S82 W18717 Gemini Drive  
Muskego, WI, 53150  
Phone: (877) 622-2694, Fax: (888) 679-3319  
www.NABCOEntrances.com

Date: July 26, 2017

Who is the contact?  
Technical Support Department

## **Sensor Monitoring will soon be part of the ANSI A156.10 Power Operated Pedestrian Door Standard (does NOT apply to Low Energy doors)**

### **What exactly changed in the Standard?**

From the Sensor section of the Standard:

*“**8.1.4** Monitoring Automatic sliding, swinging, and folding door systems shall include a means to verify each presence sensor’s functionality, and the interface between the automatic door control system and each presence sensor as required in 8.2.2, 8.3.2, and 8.4.2 and, where applicable, in Section 9. A detected fault shall cause automatic operation to cease until the fault is corrected. At a minimum, monitoring shall occur once prior to closing. (See Appendix E-6)”*

### **Do ALL doors have to comply?**

Appendix E-6 of the new standard “Grandfathered” all older installations:

*“**E-6** Each revision of the standard recognizes innovation and technological advances in products and their application since the last standard revision. Presence Sensor/Mat Monitoring is new to the 2017 revision of this standard. It is not mandatory to include presence sensor/mat monitoring on door systems installed prior to the publication of this standard revision. Compliance with the requirements of the new standard on existing installations may be determined by applicable local building codes.”*

Bulletin Number: **86**

S82 W18717 Gemini Drive  
 Muskego, WI, 53150  
 Phone: (877) 622-2694, Fax: (888) 679-3319  
 www.NABCOEntrances.com

Date: July 26, 2017

Who is the contact?  
 Technical Support Department

## Sensor Monitoring will soon be part of the ANSI A156.10 Power Operated Pedestrian Door Standard

### How does sensor monitoring work?

1. A sensor detects someone and tells the control to open the door.
2. Once the door is open and all sensors are clear, the control sends a signal to each safety sensor's Test input to ask if they are functioning properly.

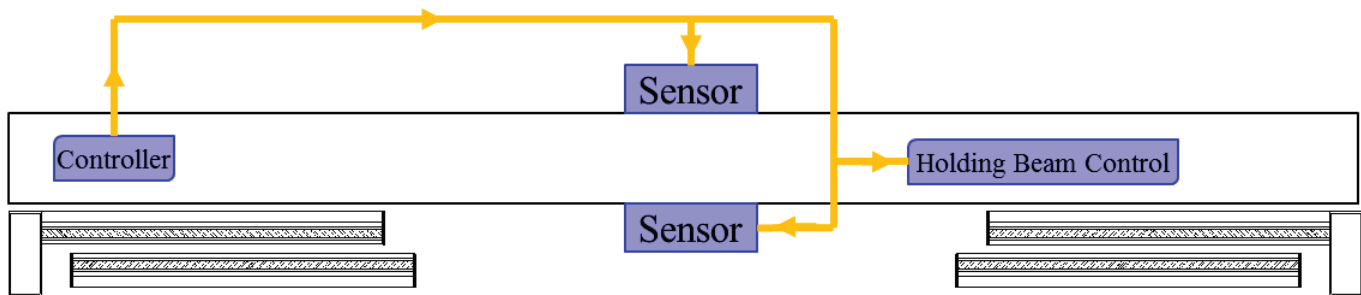

3. Each sensor responds on their individual outputs.

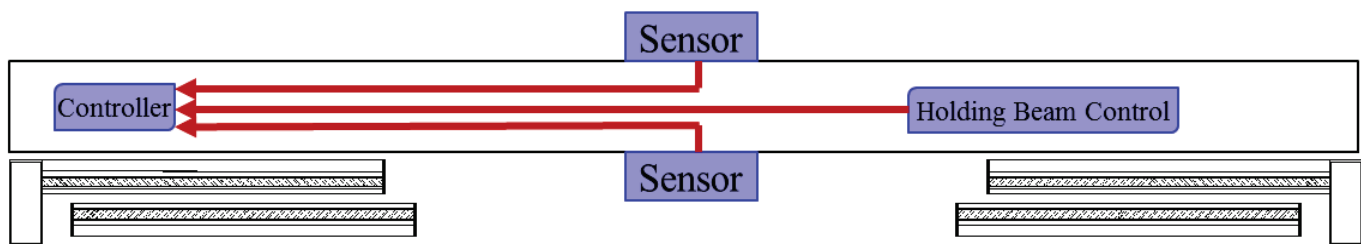

4. If ALL monitored sensors respond that they are OK then the control closes the door.
5. If ANY sensor fails to respond properly, the control holds the door open until the problem with that sensor is resolved.
6. On NABCO products, the control will display an Error, for diagnostic purposes, that specifies which sensor has the fault (the error notification is not a required part of the ANSI standard). If the unit has a U30 Microprocessor, the Error will be displayed on the Handy Terminal. If it's an Opus, then the Error will display on the LCD screen.

Bulletin Number: **86**

S82 W18717 Gemini Drive  
 Muskego, WI, 53150  
 Phone: (877) 622-2694, Fax: (888) 679-3319  
 www.NABCOEntrances.com

Date: July 26, 2017

Who is the contact?  
 Technical Support Department

## Sensor Monitoring will soon be part of the ANSI A156.10 Power Operated Pedestrian Door Standard

### Which sensors must be monitored?

ALL presence sensors including safety mats must be monitored. Saying it a different way, any sensor that provides a safety zone for an automatic door must be monitored. So if an activation sensor also provides a safety zone, it must be monitored. Activation only sensors don't need to be. See illustrations below:

### Slide Doors

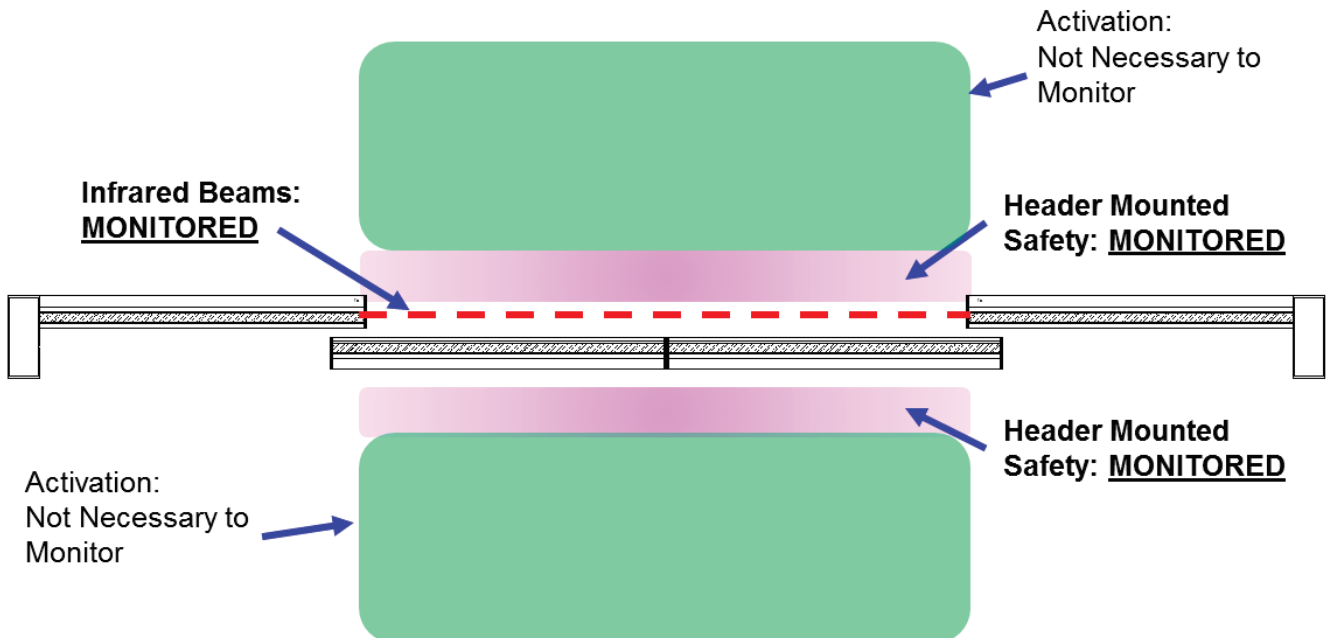

Bulletin Number: **86**

S82 W18717 Gemini Drive  
 Muskego, WI, 53150  
 Phone: (877) 622-2694, Fax: (888) 679-3319  
 www.NABCOEntrances.com

Date: July 26, 2017

Who is the contact?  
 Technical Support Department

## Sensor Monitoring will soon be part of the ANSI A156.10 Power Operated Pedestrian Door Standard

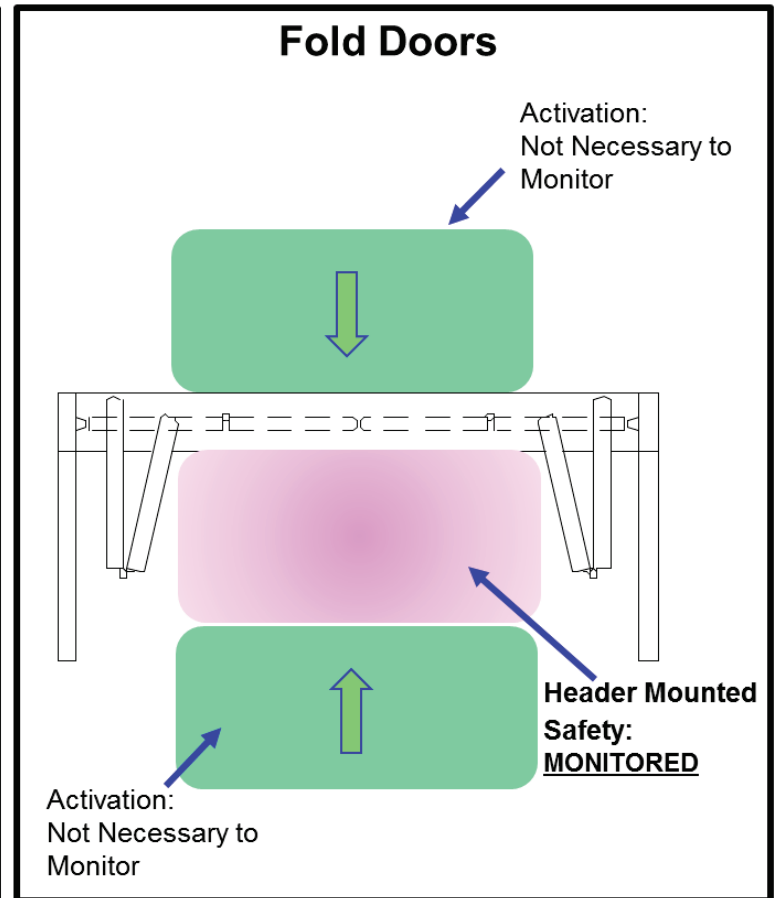
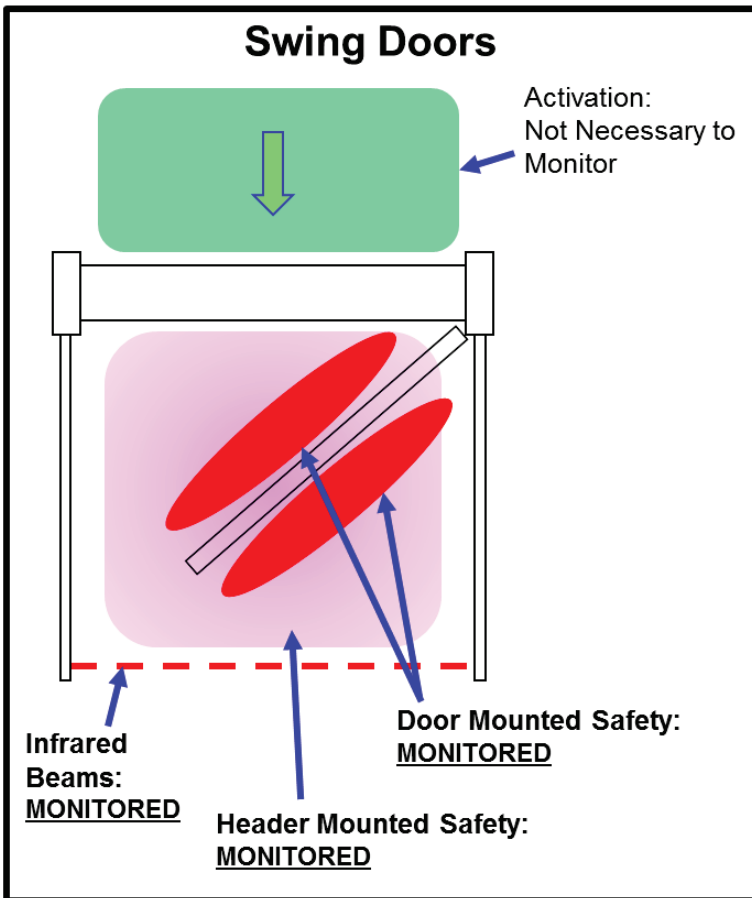

Bulletin Number: **86**



S82 W18717 Gemini Drive  
Muskego, WI, 53150  
Phone: (877) 622-2694, Fax: (888) 679-3319  
www.NABCOEntrances.com

Date: July 26, 2017

Who is the contact?  
Technical Support Department

## Sensor Monitoring will soon be part of the ANSI A156.10 Power Operated Pedestrian Door Standard

Which sensors, that NABCO sells, have monitoring?

### Slide door sensors

Acusensor M  
Acuzone T  
i-One T  
OS-12C T Holding beams  
IXIO-DT1

### Swing door sensors

Pro-Swing Elite T  
OA-Edge T

Which sensors, that NABCO sells, do NOT have monitoring?

Acuvision  
Reaction Two

Will I have to rewire new GT1175 units?

No. NABCO has been shipping units that are wired for and capable of monitoring since late fall of 2016. U30 controls have monitoring capabilities starting with Revision E which became available last fall as well.

The final letter designates the Revision



Bulletin Number: **86**

S82 W18717 Gemini Drive  
 Muskego, WI, 53150  
 Phone: (877) 622-2694, Fax: (888) 679-3319  
 www.NABCOEntrances.com

Date: July 26, 2017

Who is the contact?  
 Technical Support Department

## Sensor Monitoring will soon be part of the ANSI A156.10 Power Operated Pedestrian Door Standard

How do I set up monitoring on a new Slide Door?

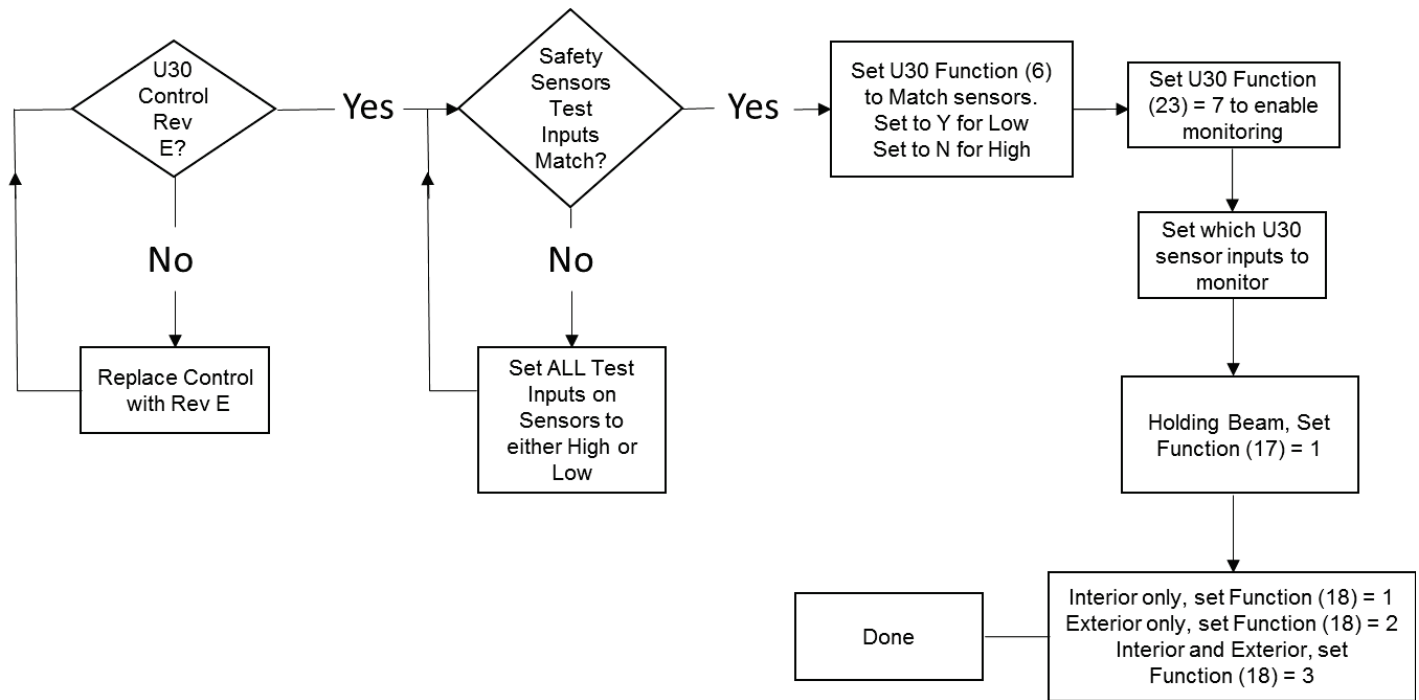

Verify that you have a U30 Rev E control. Only the Rev E has monitoring capability. Monitored sensors have a test input that is either High or Low. All sensors that are to be monitored MUST be set the same, all High or all Low. If not set properly, the door will stay open forever. The U30 control must be set to the same High or Low as the sensors, Function (6). It must also have monitoring enabled on its Auxiliary Output 2, Function (23). Finally you must tell it which input lines are to be monitored: holding Beams (Function (17)), interior or exterior sensors (Function (18)).

Bulletin Number: **86**



S82 W18717 Gemini Drive  
Muskego, WI, 53150  
Phone: (877) 622-2694, Fax: (888) 679-3319  
www.NABCOEntrances.com

Date: July 26, 2017

Who is the contact?  
Technical Support Department

## Sensor Monitoring will soon be part of the ANSI A156.10 Power Operated Pedestrian Door Standard

### What all needs to be replaced to retrofit an existing door?

#### Slide Doors:

If the door has a U30 Revision E then it probably has a yellow wire that connects all the sensors Test inputs. It also probably has monitoring capable sensors. If so, then you just need to setup the sensors and the U30 for monitoring.

If the door has a U30 but it isn't a Revision E then you would need to replace the control in addition to adding a wire to connect all the sensor's Test inputs. You would also have to replace the existing sensors with monitoring capable sensors if they aren't already. Then you would just have to set up the sensors and U30 for monitoring.

If you have a U00 through U19 control then your least expensive route would be to replace the control with an Opus board. Opus has monitoring built in so you would just have to get monitoring capable sensors and run a wire to each of the Test inputs. Retrofit kits are available through your NABCO branch office.

#### Swing Doors:

If a swing door has an Opus control then it is already monitoring capable. You just need to setup the monitoring capable sensors and the Opus for monitoring.

If a swing door has a Magnum, analog, or U19 or earlier control then you would need to replace that control with an Opus in addition to adding a wire to connect all the sensor's Test inputs. You would also have to replace the existing sensors with monitoring capable sensors. Opus retrofit kits for swing doors are available through your NABCO branch office.

#### Fold Doors:

If a fold door has an Opus control then it is already monitoring capable. You just need to setup the monitoring capable sensors and the Opus for monitoring.

If a fold door has a Magnum or U19 or earlier control then you would need to replace that control with an Opus in addition to adding a wire to connect all the sensor's Test inputs. You would also have to replace the existing sensors with monitoring capable sensors. Opus retrofit kits for fold doors are available through your NABCO branch office.

Bulletin Number: **86**