



GT400-500-600-8400-8500-8600
Opus Swing Doors C.U. Quick Set-Up and Parts Guide
P/N C-00174 Rev 8-10-16

Nabco Entrances Inc. S82 W18717 Gemini Drive Muskego, Wisconsin 53150
Phone: (877) 622-2694 Fax: (888) 679-3319 www.nabcoentrances.com

This document is meant to serve as a Quick Set-Up and Parts Guide only.
Installation manuals referenced below should be downloaded and reviewed for complete installation instructions.

Associated Manuals Part Numbers: Opus Control Wiring and Programming QSPG; P/N C-00139
Analog Control Wiring and Adjustment Manual; P/N 15-10745
Conversion Unit Hardware Installation Manual with Opus Control; 15-14985
GT Swing Door Owner's Manual; P/N C-00110 (for Decal Installation)
NABCO Price Book P/N 16-9244-30 (for Sensors, Switches, and Accessories)

WARNING

- Turn OFF all power to the Automatic Door if a Safety System is not working.
- Instruct the Owner to keep all power turned OFF until corrective action can be achieved by a NABCO trained technician. Failure to follow these practices may result in serious consequences.
- NEVER leave a Door operating without all Safety detection systems operational.

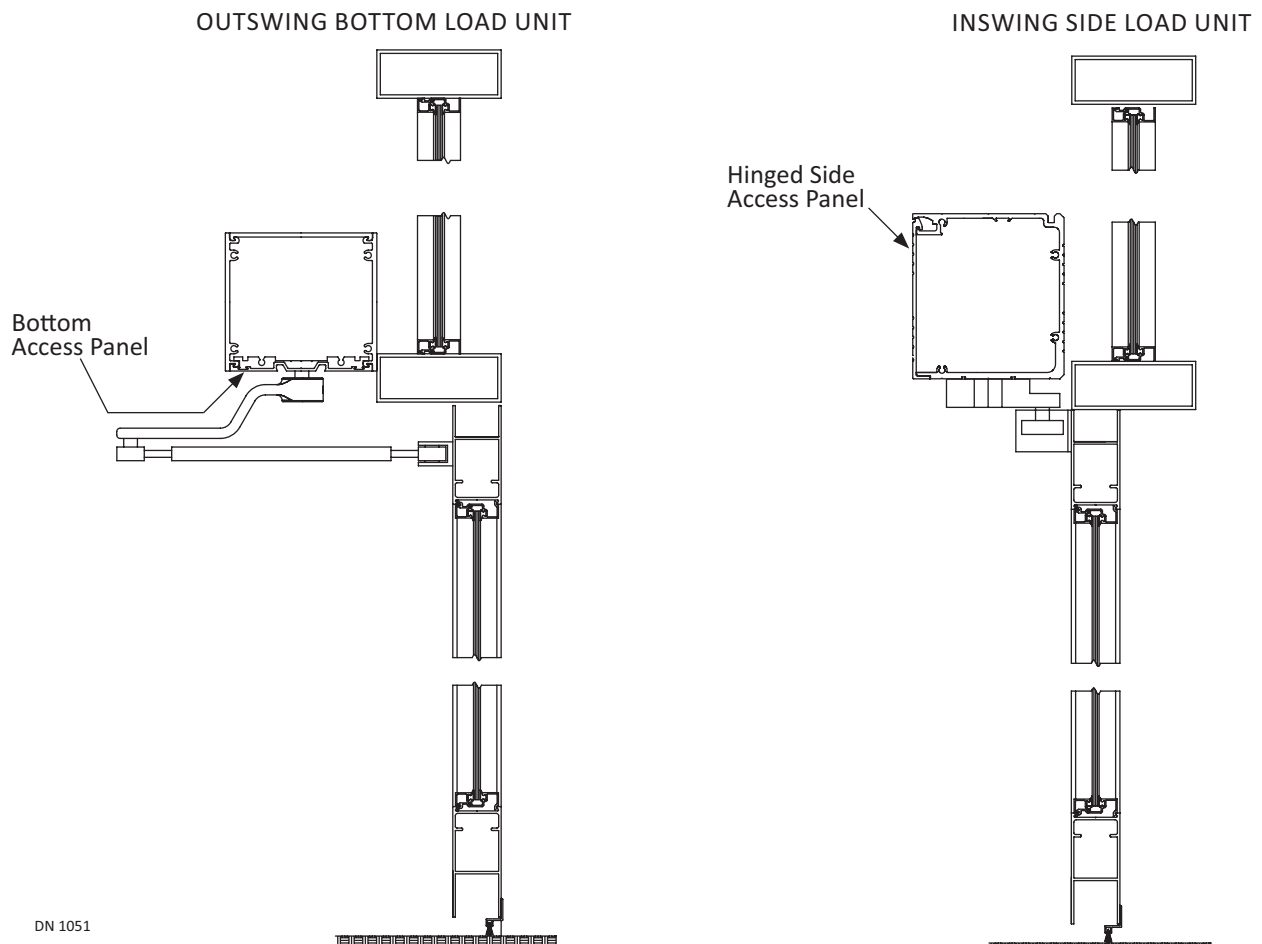

Table of Contents

SECTION 1: TO THE INSTALLER 3

SECTION 2: BEFORE INSTALLING THE HEADER 3

SECTION 3: INSTALL THE BOTTOM LOAD HEADER 3

SECTION 4: SECURE THE HEADER TO DOOR FRAME 5

SECTION 5: INSTALL BOTTOM LOAD COMPONENTS 6

SECTION 6: INSTALL THE SIDE LOAD HEADER 8

SECTION 7: 120 VAC GENERAL WIRING 11

SECTION 8: HANDING 12

SECTION 9: INSTALL THE FIRST HALF OF SWING ARM 13

SECTION 10: INSTALL THE SECOND HALF OF SWING ARM 16

SECTION 11: INSTALL THE ARM STOP (SIDE LOAD UNITS) 18

SERVICE PARTS: C.U. OPUS BOTTOM LOAD HEADER 19

SERVICE PARTS: C.U. ANALOG BOTTOM LOAD HEADER 22

SERVICE PARTS: C.U. OPUS SIDE LOAD HEADER 25

SERVICE PARTS: C.U. ANALOG SIDE LOAD HEADER 28

SERVICE PARTS: SWING ARM ASSEMBLIES 30

SECTION 1: TO THE INSTALLER

The purpose of this manual is to familiarize the installer and purchaser with the proper installation and operation of this system. It is essential that this equipment be properly installed and operational before the door is used by the public. It is the installer’s responsibility to inspect the operation of the entrance system to be sure it complies with any applicable standards. In the United States, ANSI Standard 156.10 (Used to cover Full Energy doors) and ANSI Standard 156.19 (Used to cover Low Energy doors) apply. Other local standards or codes may apply. Use them in addition to the ANSI standards. The owner should determine the door is operating properly and should immediately call for service if there is any malfunction. All installation changes and adjustments must be made by qualified, NABCO trained technicians.

Swing Door Conversion Units are designed to be installed onto the top surface of the Door Frame. The Operator is controlled by the Opus Control (Standard) or by the Analog Control (Optional).

SECTION 2: BEFORE INSTALLING THE HEADER

1. Open the Inswing door 90 degrees.
 - a. Outswing doors do not need to be measured.
2. Measure between the wall and the outside face of the Swing Door.
 - a. There must be a 2 inch minimum gap. If there is less than a 2 inch gap, please call Customer Service at (877) 622-2694.

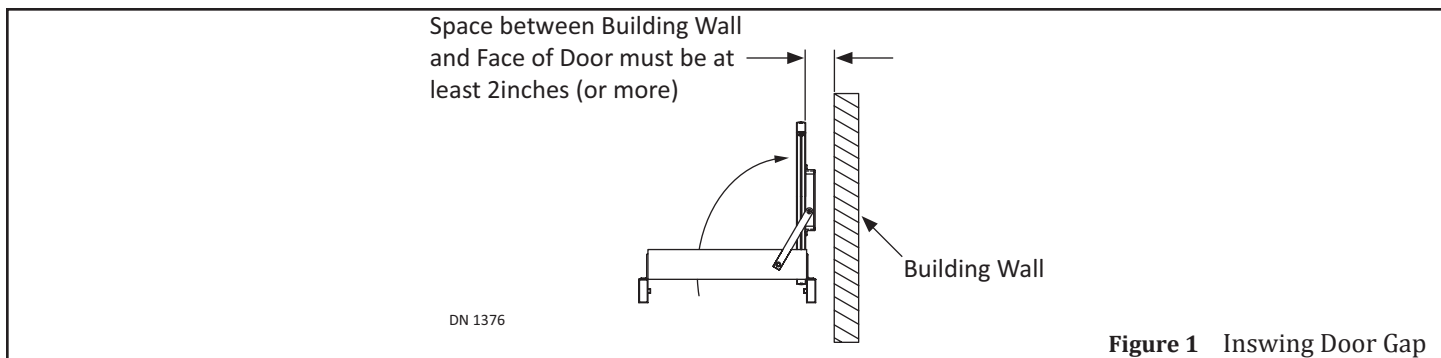

SECTION 3: INSTALL THE BOTTOM LOAD HEADER

FOR SIDE LOAD UNITS SKIP TO SECTION 6

3.1 Prepare the Header

1. Place Header on flat surface with Bottom facing up. Protect Header from scratches. Remove #10-24 x 3/4 inch screws and Dress Plate. Set aside.
2. Mark the locations of each Lock Cover Plate to ensure it is reinstalled in the correct position. Remove Lock Cover Plates.
3. Remove boxes and/or parts bags from inside Header. Set aside.

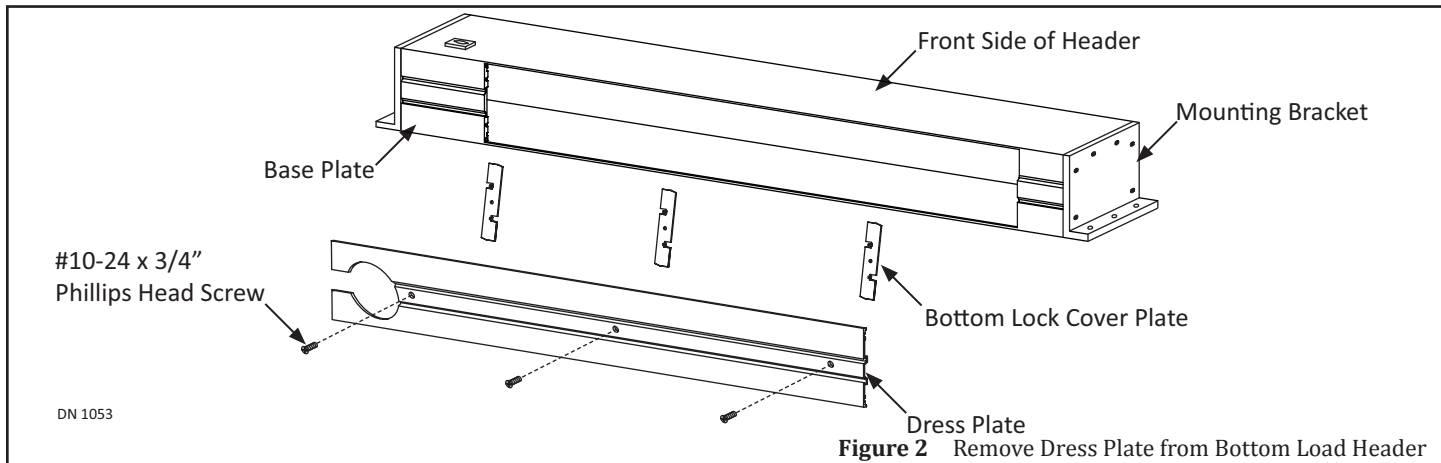

3.2 Prepare the Door Frame

3.2.1 Metal Door Frames

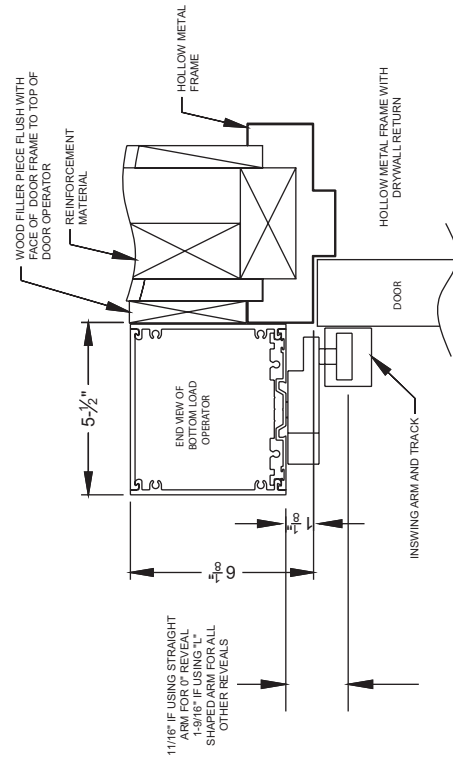

**BOTTOM LOAD
INSWING UNIT**

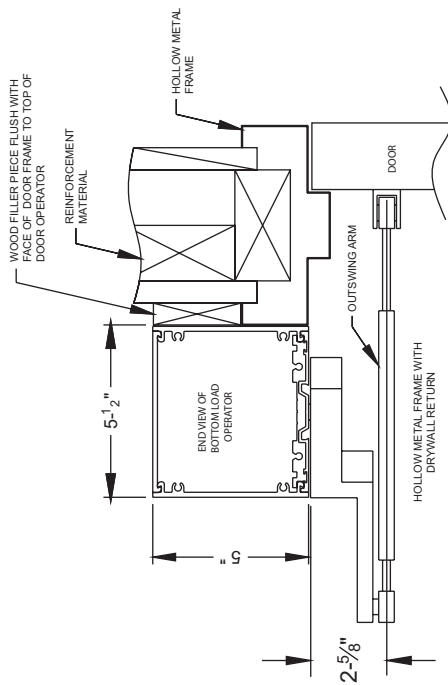

**BOTTOM LOAD
OUTSWING UNIT**

- NOTES:**
1. DOOR OPERATOR INTENDED TO MOUNT FLUSH WITH FACE OF DOOR FRAME.
 2. FINISHED WALL ABOVE MUST BE FLUSH WITH FACE OF FINISHED FRAME UP TO HEIGHT OF 8" ABOVE BOTTOM EDGE OF FRAME FACE.
 3. REINFORCEMENT MATERIAL (EITHER PLYWOOD OR SOLID STRUCTURAL LUMBER) MUST BE INSTALLED BEHIND AND/OR IN PLACE OF FINISHED WALL MATERIAL AND BE SECURED TO WALL FRAMING TO PROVIDE STRONG SURFACE FOR MOUNTING DOOR OPERATOR. IF FACE OF FRAME IS NOT FLUSH WITH FINISHED WALL, ADDITIONAL PLYWOOD IS REQUIRED AS SHOWN TO PROVIDE FLUSH AND STABLE SURFACE FOR MOUNTING DOOR OPERATOR.
 4. REFER TO INSTALLATION INSTRUCTION MANUALS FOR EACH OPERATOR FOR ADDITIONAL MOUNTING DETAILS AND DIMENSIONS.
 5. DRAWING IS FOR GENERAL REFERENCE PURPOSES ONLY AND NOT TO SCALE.

DN 1377

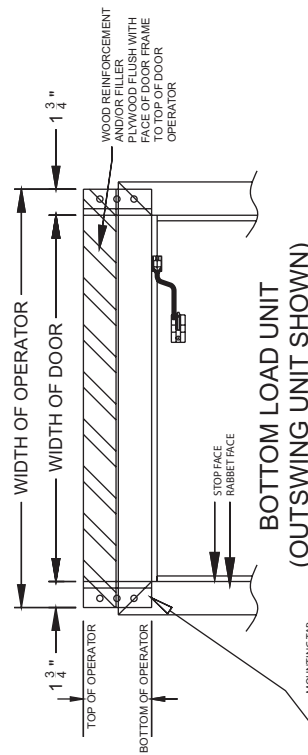

**BOTTOM LOAD UNIT
(OUTSWING UNIT SHOWN)**

3.1.2 Door Frames

Note: The following instructions are for typical Metal Doors and Frame Profile. If the Door Frame is not Metal, ensure the Door Frame being used is of equal strength. It is recommended to use lag bolts.

Note: If the Door Frame is not properly reinforced nor anchored to the building surface, and/or is hollow, reinforce the Door Frame with 1/4-20 blind rivnuts (not provided by NABCO).

1. Go to the Pivot Side of Swing door. Measure up 1-1/8 inch from the Top of Door to the face of Door Frame.
2. Mark a Horizontal Line on the face of the Top door frame, at both ends.

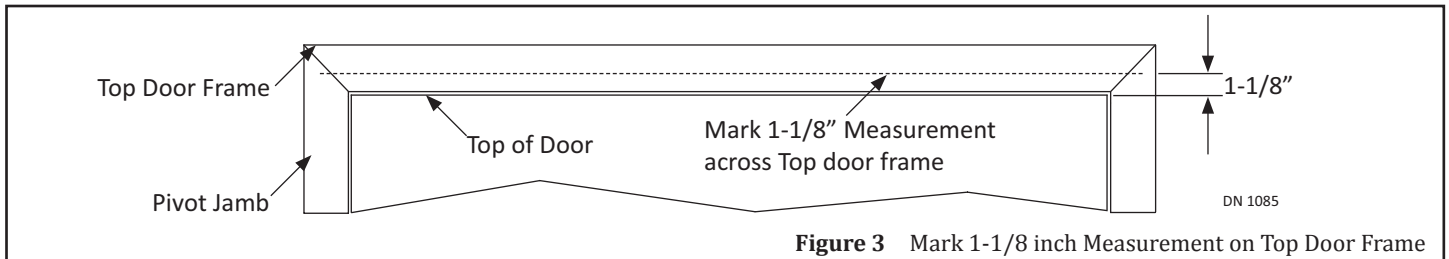

3. Lift the Header up against the Top door frame until the bottom edge of Header is butted up against the Horizontal Lines.
4. To ensure proper operation of the Swing Arm:
 - ▶ For a Door Jamb that is 1-3/4 inches wide, position the Pivot side of Header so it is flush to the outside edge of the Pivot Door Jamb.
 - ▶ For a Door Jamb that is wider than 1-3/4 inches, measure from the inner edge of the Pivot Door Jamb to the center. Mark a vertical line at the 1-3/4 inch measurement. The Pivot side of Header must butt against the 1-3/4 inch mark.

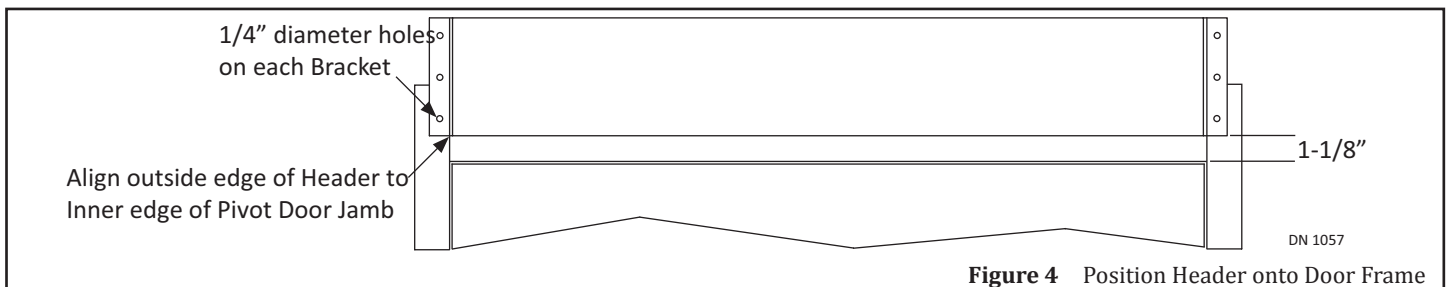

5. Ensure the Header is square and level. Use the Header as a template to mark screw holes onto the face of the door frame.
6. Remove the Header. Set Aside.

SECTION 4: SECURE THE HEADER TO DOOR FRAME

1. Lift up Header to insert Power Wiring through the 7/8 inch hole. It is recommended to use a Conduit.
 - a. It is recommended to insert all other Wiring through a separate hole.
2. Butt the bottom edge of Header against the 1-1/8 inch Horizontal Line.
3. Line up the scw holes. Secure the Header to the Door Frame.
 - a. It is recommended to use Lag Bolts.
 - b. For additional mounting, secure the Header to the Studs located behind the Shim.

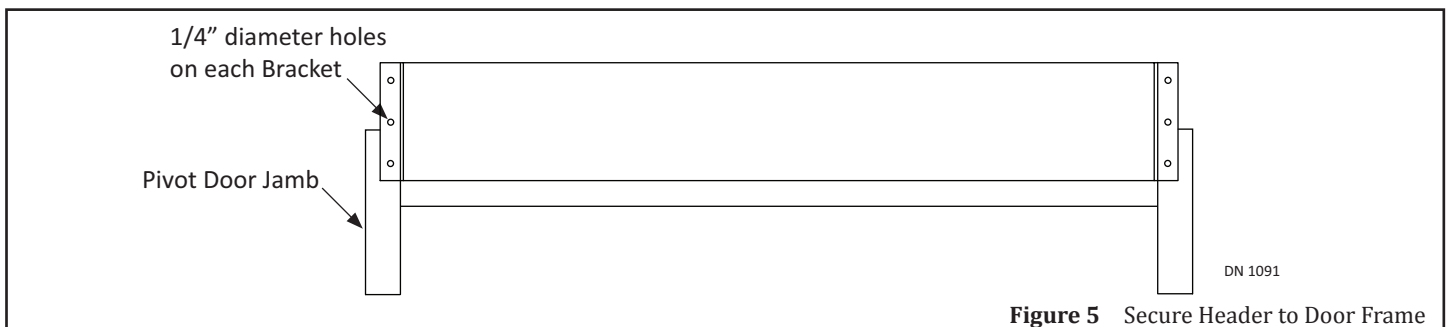

SECTION 5: INSTALL BOTTOM LOAD COMPONENTS

FOR SIDE LOAD UNITS SKIP TO SECTION 6

Note: Location of Contents within Header are subject to change according to Swing door specifications.

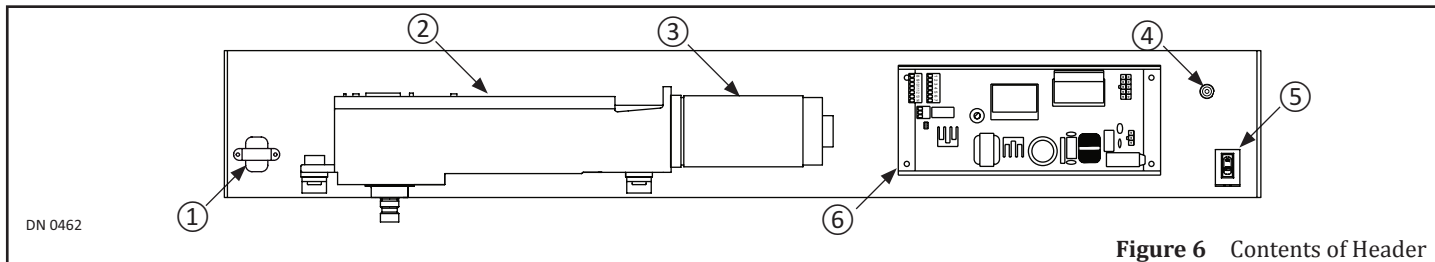

Figure 6 Contents of Header

- | | |
|---------------------------|------------------|
| 1. Transformer (Optional) | 4. Ground Screw |
| 2. Operator | 5. Rocker Switch |
| 3. Motor | 6. Control |

5.1 Secure Incoming Wires

1. Obtain (self sticking) white plastic Wire Clips provided by NABCO.
2. Adhere each Wire Clip to sides of Header. Insert wiring (as deemed necessary).
 - a. 120 VAC Power wires must be routed separate from other wiring, adhere those Wire Clips inside the Header, near the top to prevent pinching.

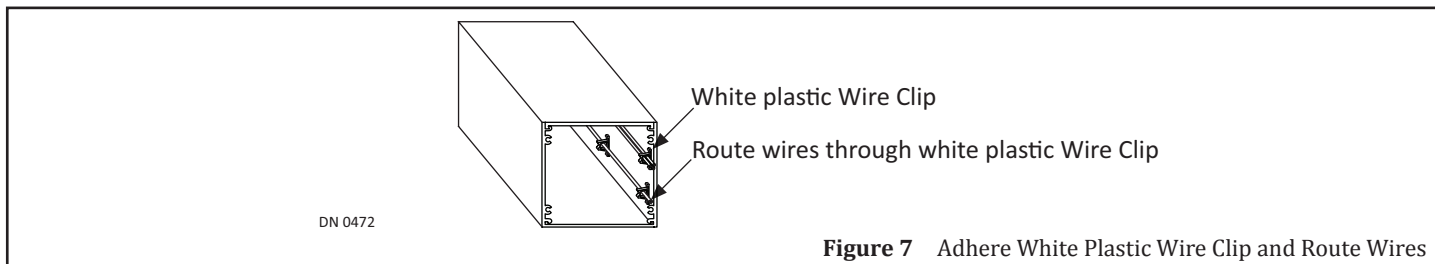

Figure 7 Adhere White Plastic Wire Clip and Route Wires

5.2 Install the Stop Ring

1. Place the Motor/Operator on a flat surface with the underside facing up.
2. Obtain the Stop Ring Assembly provided by NABCO.
3. Slide the Limit Stop onto the Spindle.
4. Secure (4) Ring Stops onto the Limit Stop with 5/16-18 Socket Head screws. Do not fully tighten at this time.
5. Once the Swing Arm is fully installed and Pre-Load has been tested:
 1. Open the Swing door 90 degrees.
 2. Rotate the Limit Stop Spindle until it hits the Swing Arm.
 3. Tighten down (4) Ring Stops with 5/16-18 Socket Head screws.

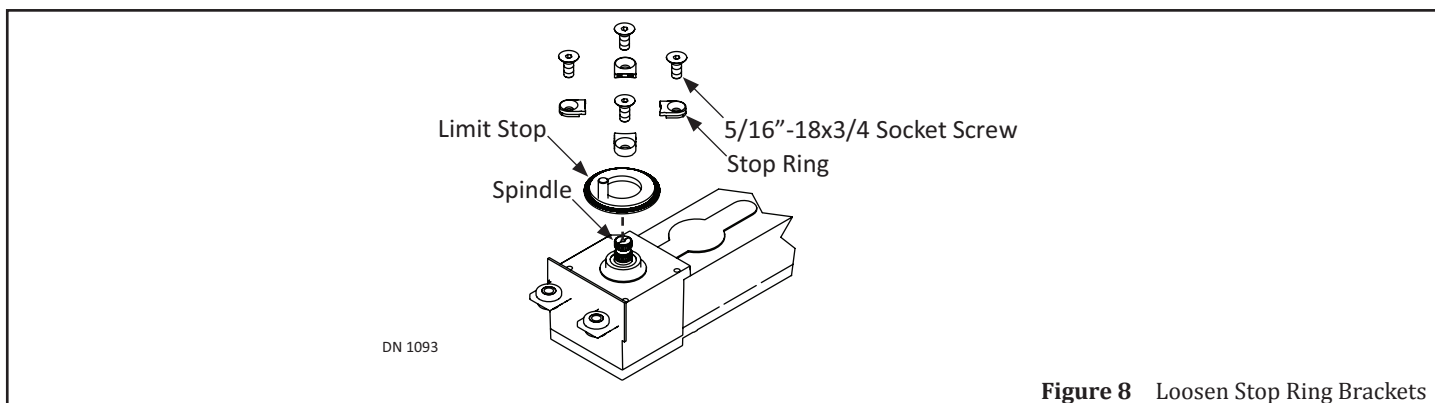

Figure 8 Loosen Stop Ring Brackets

5.3 Install the Motor/Operator

- Go to Table 1 to determine the distance from the center of the Operator Spindle to the Center Pivot or the inside edge of the Pivot Door Jamb.

Table 1 Dimension "A" Spindle Location

Bottom Load Units	Model	Pivot Type	Inswing				Outswing			
			With Fingerguard		No Fingerguard		With Fingerguard		No Fingerguard	
			Spindle Loc.	Base Plate	Spindle Loc.	Base Plate	Spindle Loc.	Base Plate	Spindle Loc.	Base Plate
GT 400	Butt/Offset	N/A	N/A	5"	2-1/2"	N/A	N/A	7-1/4"	4-3/4"	
	Center Pivot	6"	3-1/2"	5"	2-1/2"	8-1/4"	5-3/4"	7-1/4"	4-3/4"	
GT 500	Butt/Offset	N/A	N/A	5"	2-1/2"	N/A	N/A	5"	2-1/2"	
	Center Pivot	6"	3-1/2"	5"	2-1/2"	6"	3-1/2"	5"	2-1/2"	
GT 600	Butt/Offset	N/A	N/A	5"	2-1/2"	N/A	N/A	7-1/4"	4-3/4"	
	Center Pivot	6"	3-1/2"	5"	2-1/2"	8-1/4"	5-3/4"	7-1/4"	4-3/4"	

- Mark that measurement onto the face of Swing Door.

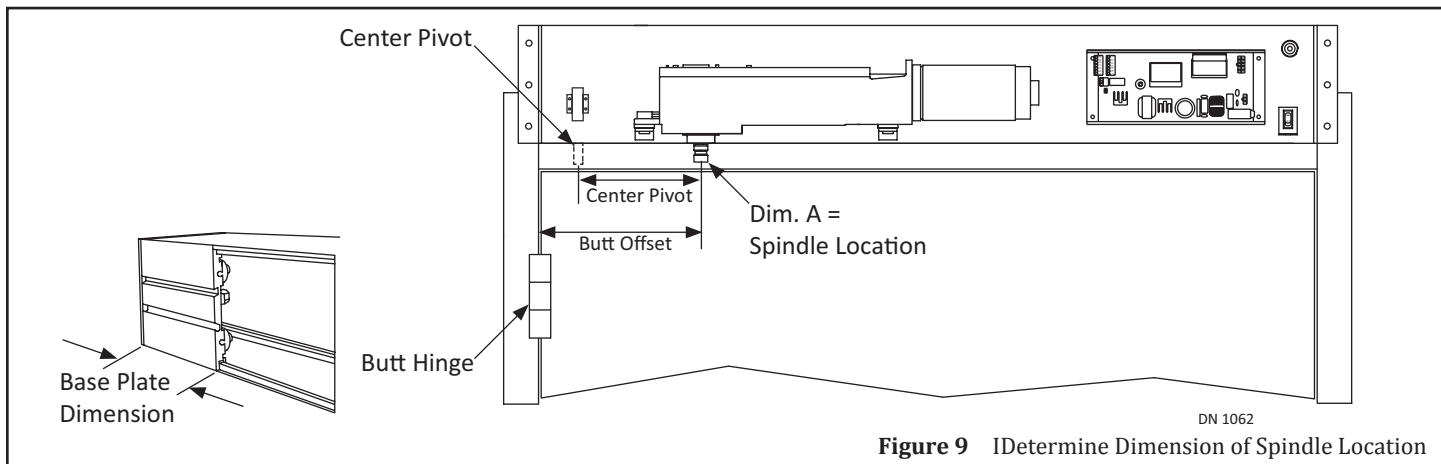

Figure 9 Determine Dimension of Spindle Location

- Locate the factory installed Rear Mount Bracket at the top of Header.
- With a 9/16 inch Deep Well Socket and Ratchet, remove (2) 3/8-16 inch Hex Jam Nuts and (2) 7/16 x 1 inch Washers from (2) Studs extending downward. Set aside.
- Hold the Front end of Motor/Operator at an upward angle to slide Front Mount onto (2) Pivot Base Tabs located inside the Header.

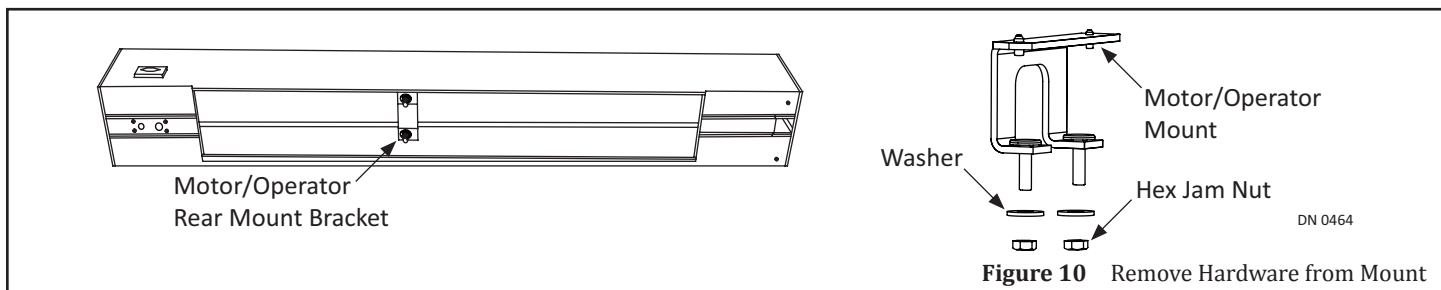

Figure 10 Remove Hardware from Mount

- Lift the rear of the Motor Operator up onto (2) studs extending downward.
 - Ensure the Switch Harness is tucked between the back wall of Header and above the Mounting Bracket.
- Secure the Motor/Operator with (2) 3/8-16 inch Hex Jam Nuts and (2) 7/16 x 1 inch Washers.
 - It is important not to pinch any wiring during the Motor/Operator installation.

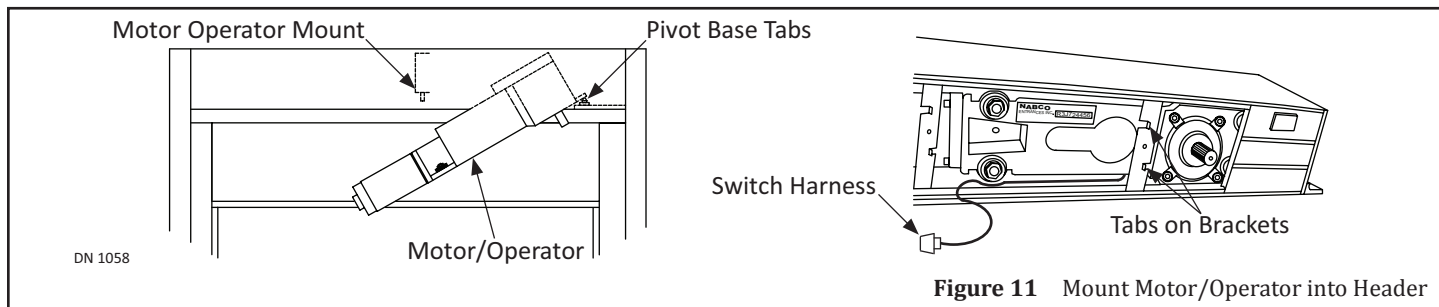

Figure 11 Mount Motor/Operator into Header

5.4 Install the Control

Note: It may be necessary to mount a Soft Starter Capacitor on the Operator prior to installing the Analog Control. For detailed information, please refer to the "Analog Control Wiring and Adjustment Manual; P/N 15-10745".

1. Obtain the Opus Control assembly.
2. Locate where the Opus Control needs to be installed within the Header.
3. Insert the Opus Control with the Mounting Bracket at a 90 degree angle (Control will approximately be at a 4 degree angle).
4. Rotate the Opus Control until each side of the Mounting Bracket slides into each Channel located at the top; inside Header.
5. Secure the Mounting Bracket to the Header by tightening (2) 10-24x.875 inch Socket Head Cap screws, until the tip butts against the inside wall of the Header.

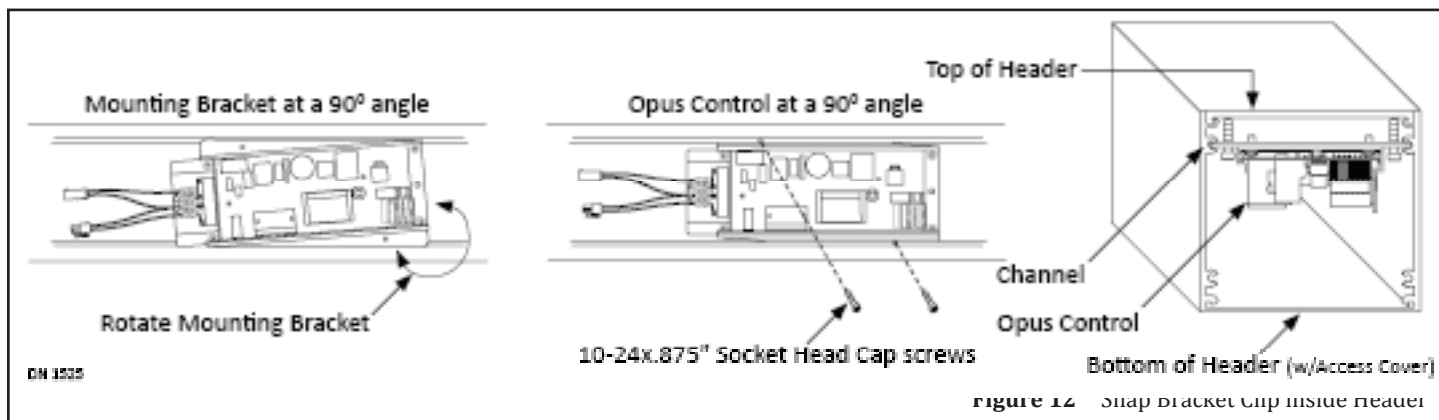

Figure 14 Snap Bracket Clip Inside Header

SECTION 6: INSTALL THE SIDE LOAD HEADER

FOR BOTTOM LOAD UNITS SKIP TO SECTION 7

6.1 Before Installing the Header

1. Open the Inswing door 90 degrees. Outswing doors do not need to be measured.
2. Measure between the wall and the outside face of the Swing Door.
 - a. There must be a 2 inch minimum gap. If there is less than a 2 inch gap, please call Customer Service at (877) 622-2694.

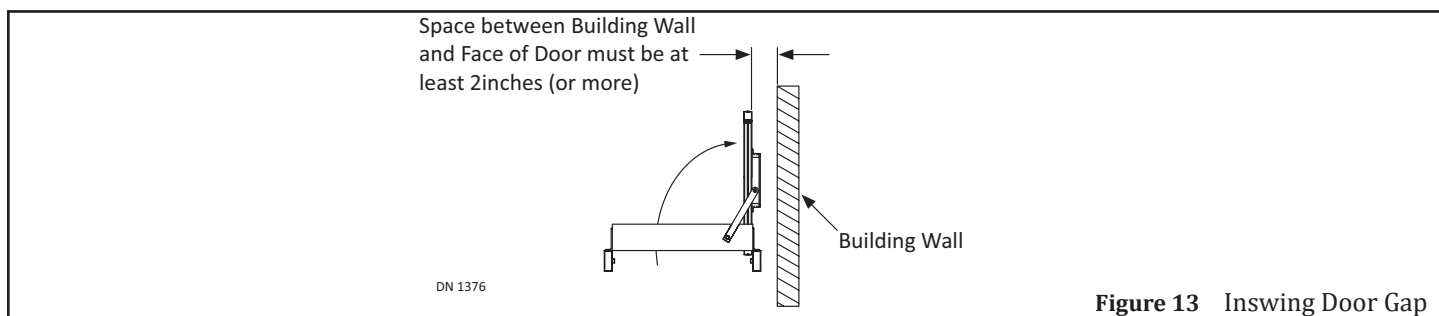

Figure 13 Inswing Door Gap

6.1.1 Drill Holes

- Go to the Strike side of Header. Drill one 7/8 inch hole through the Header to allow all wiring to be drawn inside.
 - The Side Load Header can be ordered with a Knockout hole located at either end of the Header. For details, please call Customer Service at 1-888-679-3319.
- Go to the back wall inside Header on the Pivot side.
- Measure 1 inch from the End Cap towards the center of Header. Mark a Horizontal Line.
- Measure at least 1/2 inch from the bottom of Header towards the top. Mark a Vertical Line across the Horizontal line. This is the center of the first screw hole. Drill 1/4 inch screw hole.
- Measure at least 1/2 inch from the top of Header towards the bottom. Mark (1) more Horizontal line across the Vertical line directly above the first screw hole. This is the center of the second screw hole. Drill 1/4 inch screw hole.
- Go to the other End Cap. Repeat steps 3 thru 5.

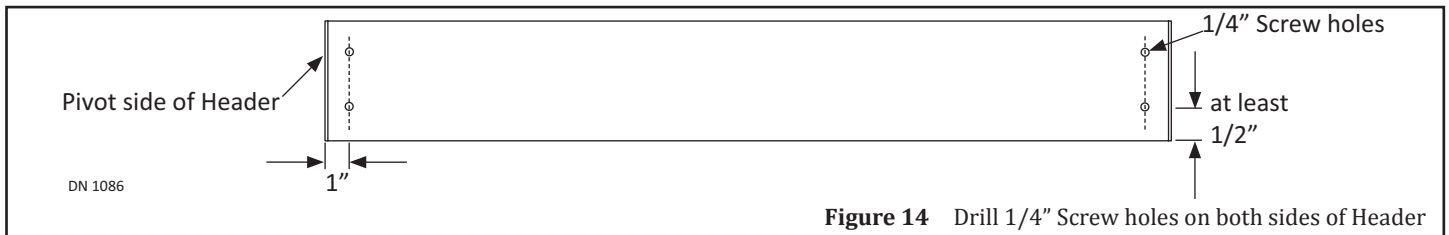

Figure 14 Drill 1/4" Screw holes on both sides of Header

6.2 Prepare the Door Frame

6.2.1 Non-Metal Door Frames

Note: If the Door Frame is not properly reinforced nor anchored to the building surface, and/or is hollow, reinforce the Door Frame with 1/4-20 blind rivnuts (not provided by NABCO).

Note: If the Door Frame is not Metal, ensure the Door Frame being used is of equal strength.

- Go to the Pivot Side of Swing door. Measure up 1-1/8 inch from the Top of door to the face of Door Frame.
- Mark a Horizontal Line onto the face of the Top door frame, at both ends.

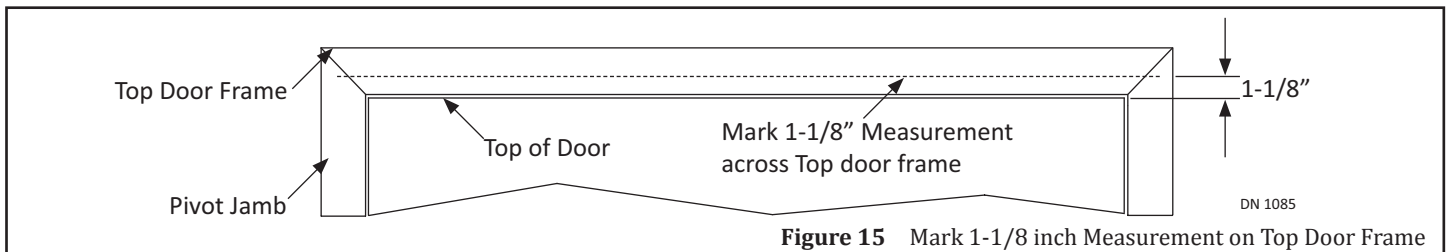

Figure 15 Mark 1-1/8 inch Measurement on Top Door Frame

- Lift the Header up to butt the bottom edge of Header against the Horizontal Line, at both ends.
- To ensure proper operation of the Swing Arm:
 - ▶ For a Door Jamb that is 1-3/4 inches wide, position the Pivot side of Header so it is flush to the outside edge of the Pivot Door Jamb.
 - ▶ For a Door Jamb that is wider than 1-3/4 inches, measure from the inner edge of the Pivot Door Jamb to the center. Mark a vertical line at the 1-3/4 inch measurement. The Pivot side of Header must butt against the 1-3/4 inch mark.
- Ensure the Header is square and level.
- Use the Header as a template to mark screw holes onto the face of the door frame. Remove the Header. Set Aside.

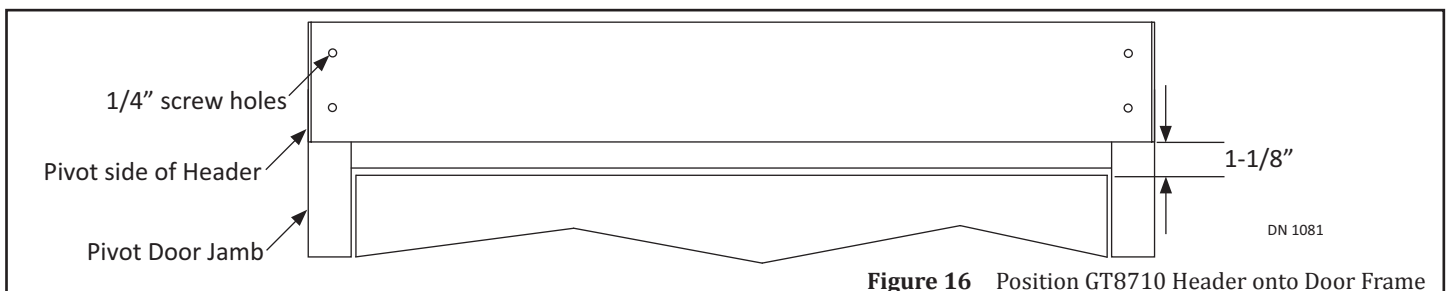
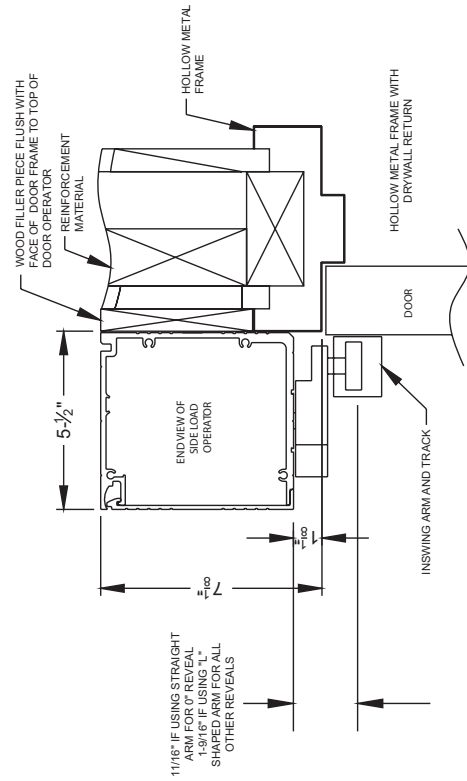

Figure 16 Position GT8710 Header onto Door Frame

6.2.2 Metal Door Frames



**SIDE LOAD
INSWING UNIT**

NOTES:

1. DOOR OPERATOR INTENDED TO MOUNT FLUSH WITH FACE OF DOOR FRAME.
2. FINISHED WALL ABOVE MUST BE FLUSH WITH FACE OF FINISHED FRAME UP TO HEIGHT OF 8" ABOVE BOTTOM EDGE OF FRAME FACE.
3. REINFORCEMENT MATERIAL (EITHER PLYWOOD OR SOLID STRUCTURAL LUMBER) MUST BE INSTALLED BEHIND AND/OR IN PLACE OF FINISHED WALL MATERIAL AND BE SECURED TO WALL FRAMING TO PROVIDE STRONG SURFACE FOR MOUNTING DOOR OPERATOR. IF FACE OF FRAME IS NOT FLUSH WITH FINISHED WALL, ADDITIONAL PLYWOOD IS REQUIRED AS SHOWN TO PROVIDE FLUSH AND STABLE SURFACE FOR MOUNTING DOOR OPERATOR.
4. REFER TO INSTALLATION INSTRUCTION MANUALS FOR EACH OPERATOR FOR ADDITIONAL MOUNTING DETAILS AND DIMENSIONS.
5. DRAWING IS FOR GENERAL REFERENCE PURPOSES ONLY AND NOT TO SCALE.

DN 1378

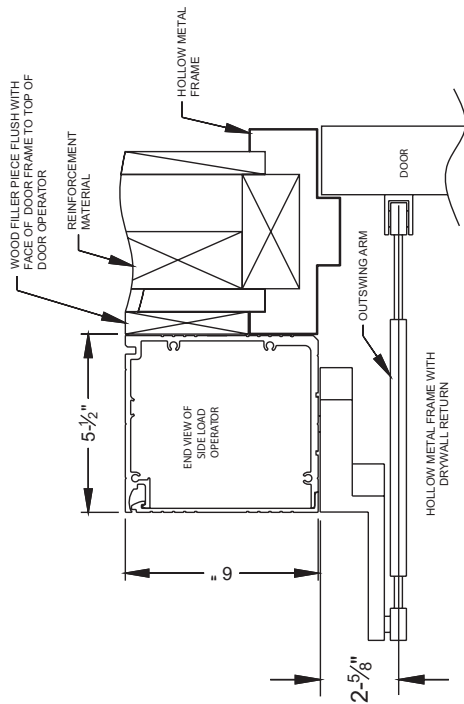

**SIDE LOAD
OUTSWING UNIT**

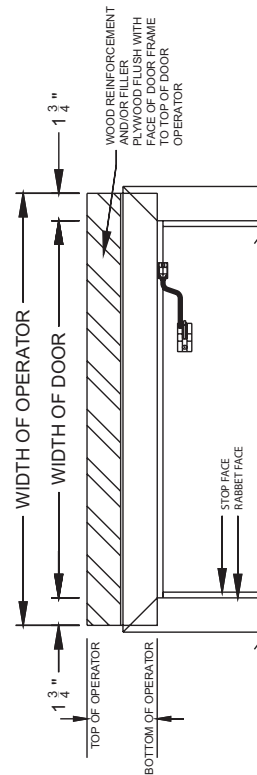

**SIDE LOAD UNIT
(OUTSWING UNIT SHOWN)**

6.3 Secure the Header to the Door Frame

1. Lift up the Header to insert Power Wiring through the 7/8 inch hole located at the left or right side of Header End Cap.
 - a. It is recommended to use a Conduit.
 - b. It is recommended to insert all other Wiring through a separate hole.
2. Line up the screw holes. Secure the Header to the Door Frame. It is recommended to use Lag Bolts.
 - a. For additional mounting, secure the Header to the Studs located behind the Shim. It is recommended to use Lag Bolts.

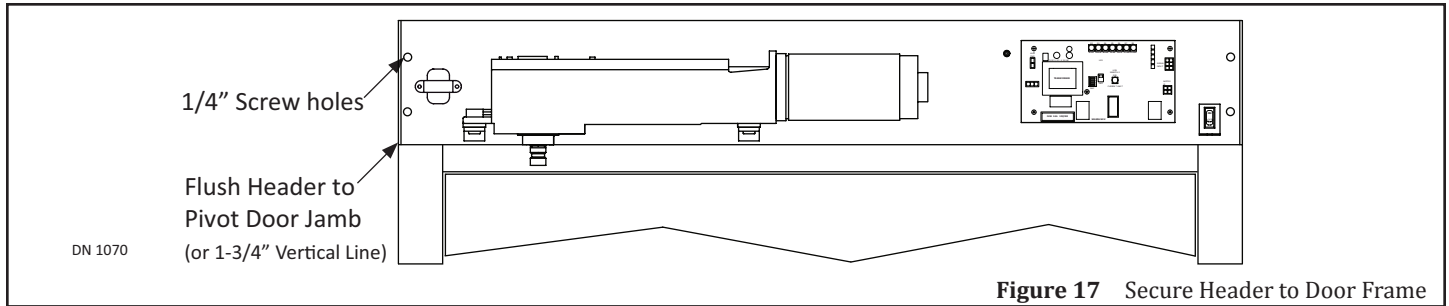
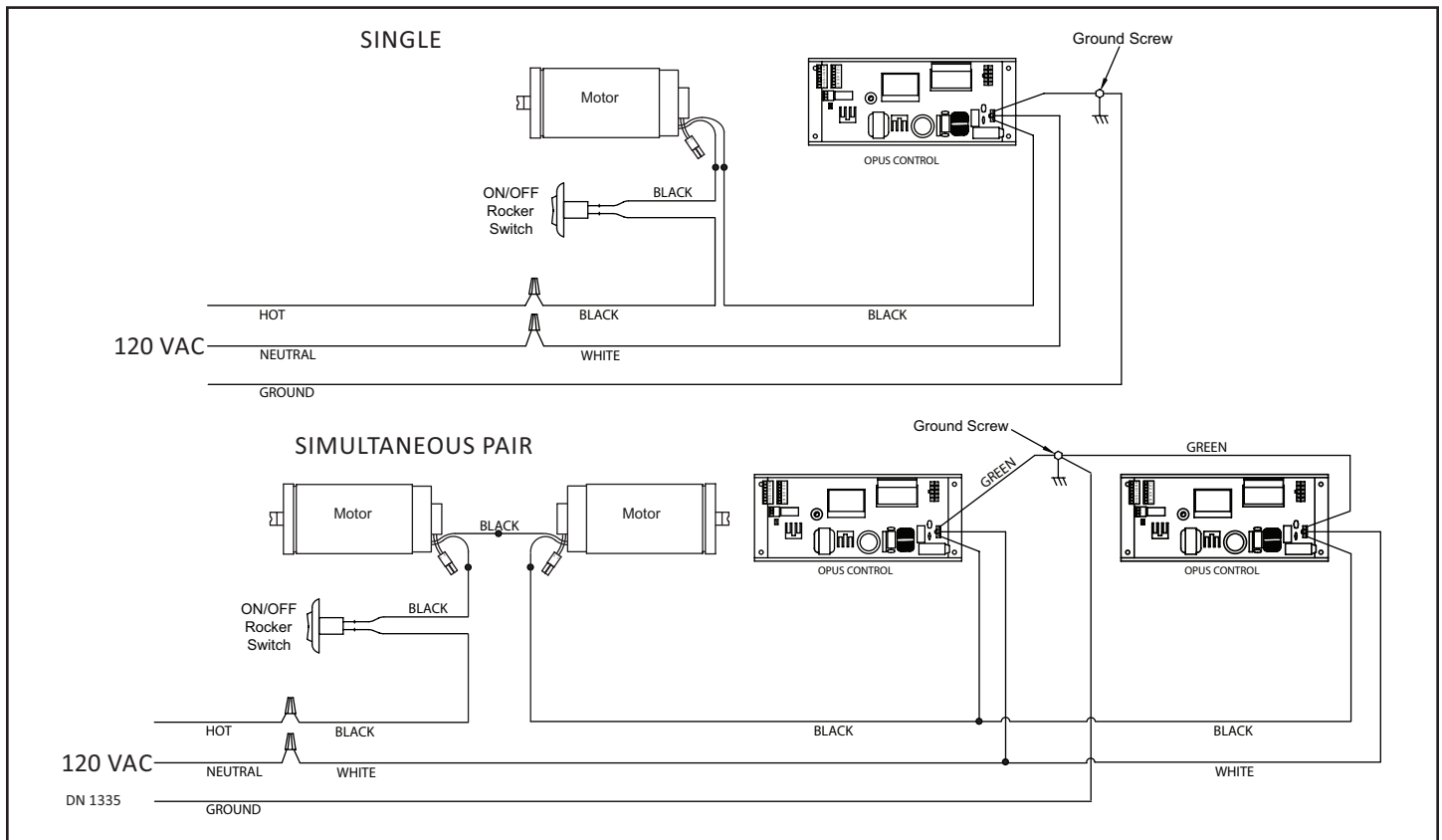

Figure 17 Secure Header to Door Frame

SECTION 7: 120 VAC GENERAL WIRING



WARNING

Shut the installation site, branch Circuit Breaker OFF. Failure to do so may result in serious personal or fatal injury. When uncertain whether power supply is disconnected, always verify using a voltmeter.

WARNING

All high voltage electrical connections must be made by licensed electricians according to National and Local electrical codes/regulations.

CAUTION

Permanent wiring shall be employed as required by local codes.

CAUTION

Keep all Incoming 120 VAC wiring separate from low voltage wiring within Header. 120 VAC Power wires must be routed (separate from other wiring) located near the top of inside Header.

CAUTION

Ensure that the **Grounding of the Electric Power Supply** is installed/connected in a proper way (especially the PE Cable from the Building Side).

Attention: Insert all Incoming 120 VAC Power wires into the pre drilled Electric Service Access Hole located at the left or right side of Header End Cap.

Note: It is recommended for the Installer to house all Incoming 120 VAC wires within an Electrical Conduit.

SECTION 8: HANDING

8.1 How to Determine Handing

- ▶ Locate the Serial Number underneath the Operator.
 - The Letter (L) or (R) located in front of the Serial Number indicates the Handing.

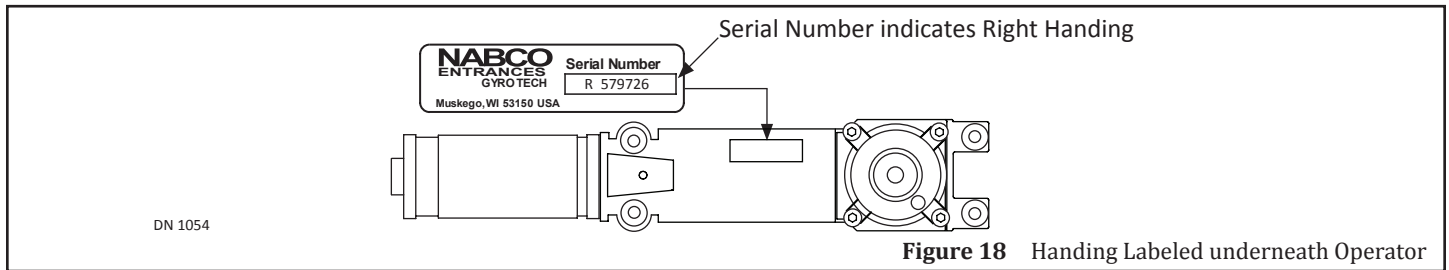

Figure 18 Handing Labeled underneath Operator

- ▶ Stand underneath the Header and then open the Swing door. Butt your back against the Pivot side of the Swing door. Swing out your (right or left) arm in the direction the Swing door opened. If you swing out your Right Arm the Swing Door is Right Handed. If you swing out your Left arm the Swing Door is Left Handed.

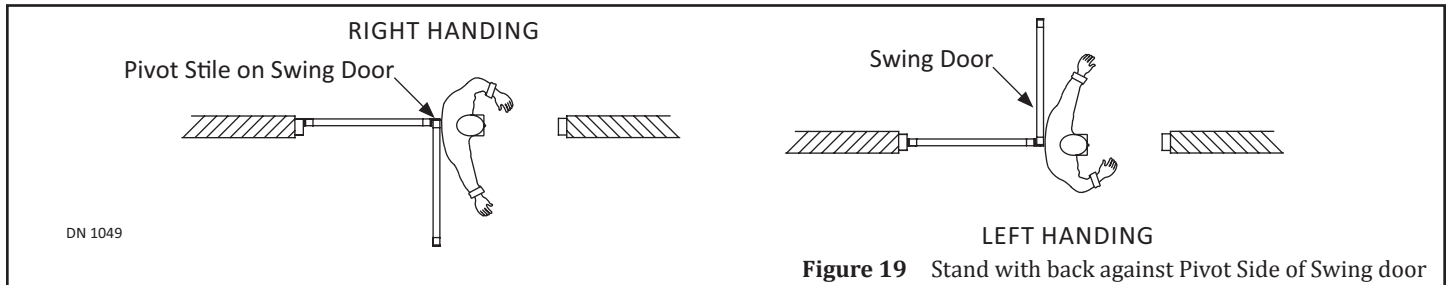

Figure 19 Stand with back against Pivot Side of Swing door

- ▶ If the Swing Arm does not swing underneath the Threshold to open, it is an Inswing Unit.
- ▶ If the Swing Arm swings underneath the Threshold to open, it is an Outswing Unit.

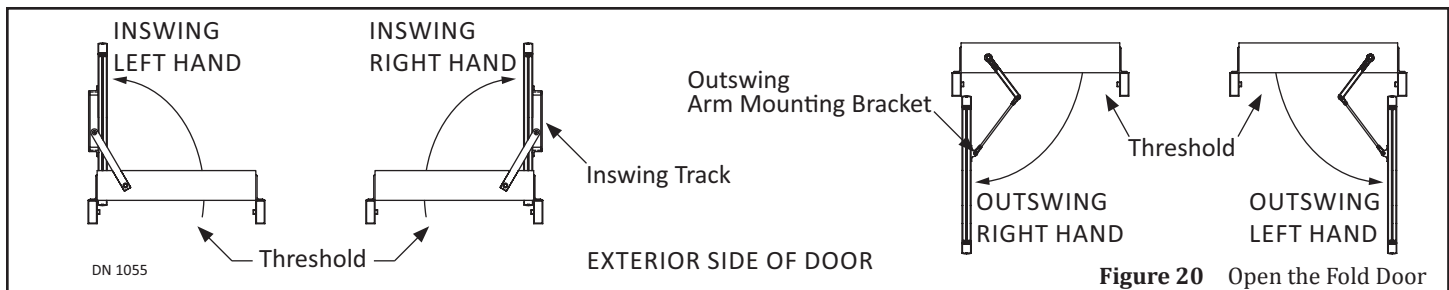

Figure 20 Open the Fold Door

8.2 Install the Handing Harness

Attention: The Handing Harness is used for Right Handed Units only. Left Handed Units do not use a Handing Harness.

1. Connect the (Break Module Harness) Female Pin to the Male Pin Housing (Handing Harness)
2. Connect the (Break Module Harness) Male Pin Housing to the Female Pin (Handing Harness).

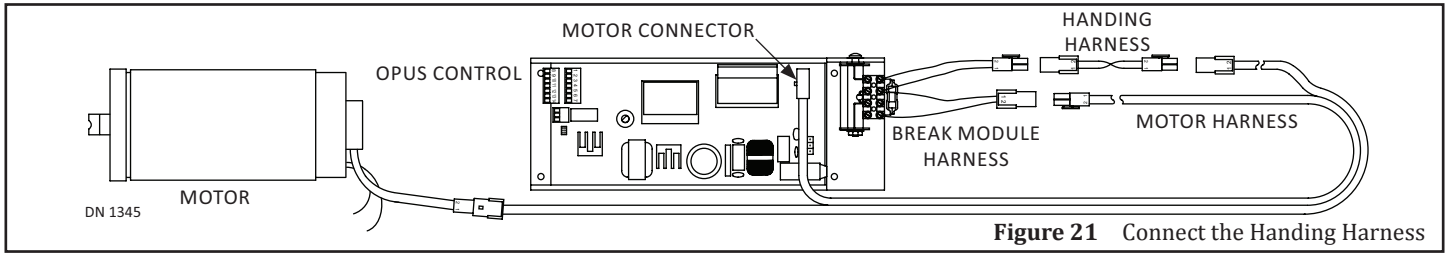

Figure 21 Connect the Handing Harness

SECTION 9: INSTALL THE FIRST HALF OF SWING ARM

9.1 Outswing Arm

FOR INSWING ARMS SKIP TO SUBSECTION 9.2

9.1.1 Prep the Swing Door

1. Measure and mark a Horizontal Line from the (Center Hinge or Butt Offset) to the center of the Face of Door according to Table 2 .

Table 2 Dimension “A” Arm Shoe Mounting Locations

Model	Pivot Type	Outswing	
		With Fingerguard	No Fingerguard
GT 400 & 8400	Butt/Offset	N/A	12-7/16”
	Center Pivot	16”	15”
GT 500 & 8500	Butt/Offset	N/A	10-3/16”
	Center Pivot	13-3/4”	12-3/4”
GT 600 & 8600	Butt/Offset	N/A	12-7/16”
	Center Pivot	16”	15”

2. Measure 1 - 1/2 inches from the Bottom of Door Frame down to the Horizontal Line. Mark a Vertical line across the Horizontal Line. This is the center of the first Sex Bolt hole.
3. Butt the Arm Shoe against the Swing door by aligning the first Sex Bolt hole with the measured Mark.
4. Ensure the Arm Shoe is square and level.
5. Use the Arm Shoe as a Template to mark the second Sex Bolt hole. Set aside.

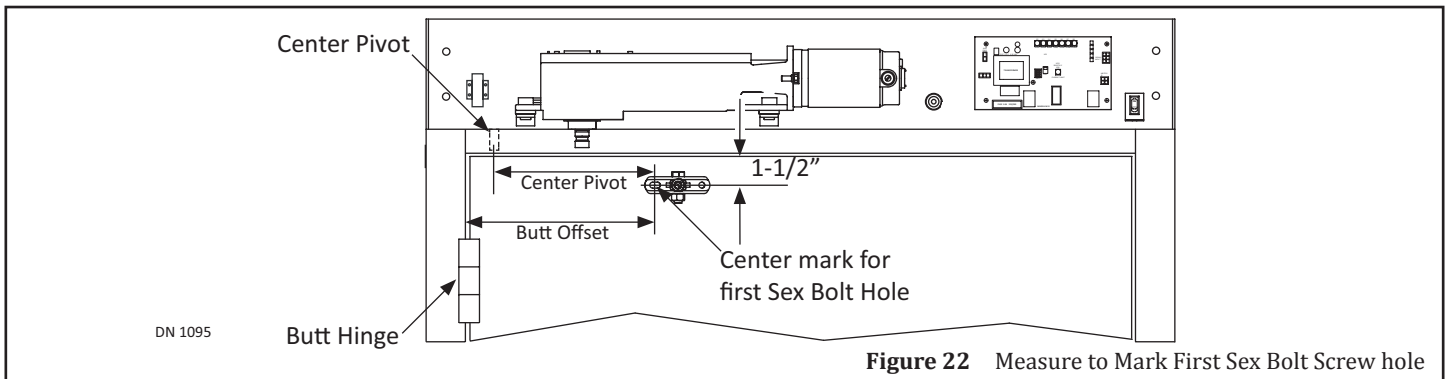

Figure 22 Measure to Mark First Sex Bolt Screw hole

9.1.2 Prep the Outswing Arm Assembly

1. Please refer to Table 3 to obtain the appropriate full length measurement of the Outswing Arm.

Table 3 Full Length of Outswing Arm

Model	Pivot Type	Reveal					
		1-1/8 inch	2-1/8 inch	3-1/8 inch	4-1/8 inch	5-1/8 inch	6-1/8 inch
GT 400 & 8400	Butt/Offset	11-7/8”	12-7/8”	13-7/8”	14-7/8’	15-7/8”	16-7/8”
	Center Pivot	12-1/2”	13-1/2”	14-1/2”	15-1/2”	16-1/2”	17-1/2”

Model	Pivot Type	Reveal					
		1-1/8 inch	2-1/8 inch	3-1/8 inch	4-1/8 inch	5-1/8 inch	6-1/8 inch
GT 500 & 8500	Butt/Offset	11-7/8"	12-7/8"	13-7/8"	14-7/8"	15-7/8"	16-7/8"
	Center Pivot	11-7/8"	12-7/8"	13-7/8"	14-7/8"	15-7/8"	16-7/8"
GT 600 & 8600	Butt/Offset	11-7/8"	12-7/8"	13-7/8"	14-7/8"	15-7/8"	16-7/8"
	Center Pivot	12-1/2"	13-1/2"	14-1/2"	15-1/2"	16-1/2"	17-1/2"

1. Remove the Swing Arm from the Threaded Rod.

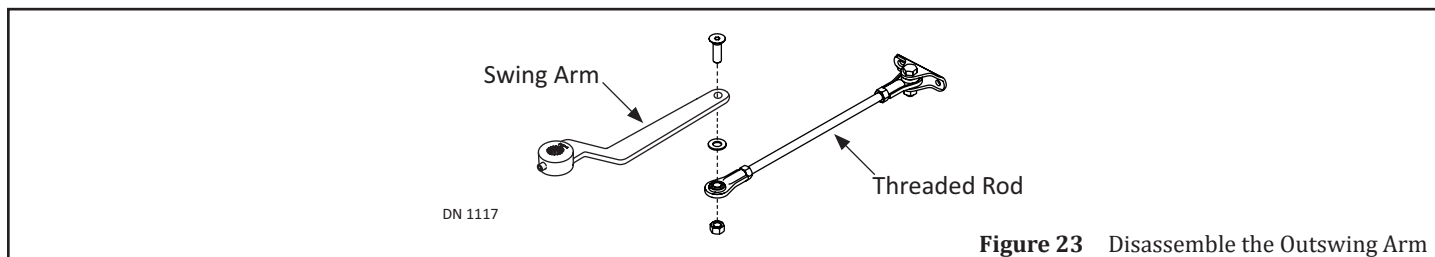

2. Measure between the center of each Eye located at each end of the Outswing Rod.
3. Write that measurement down.

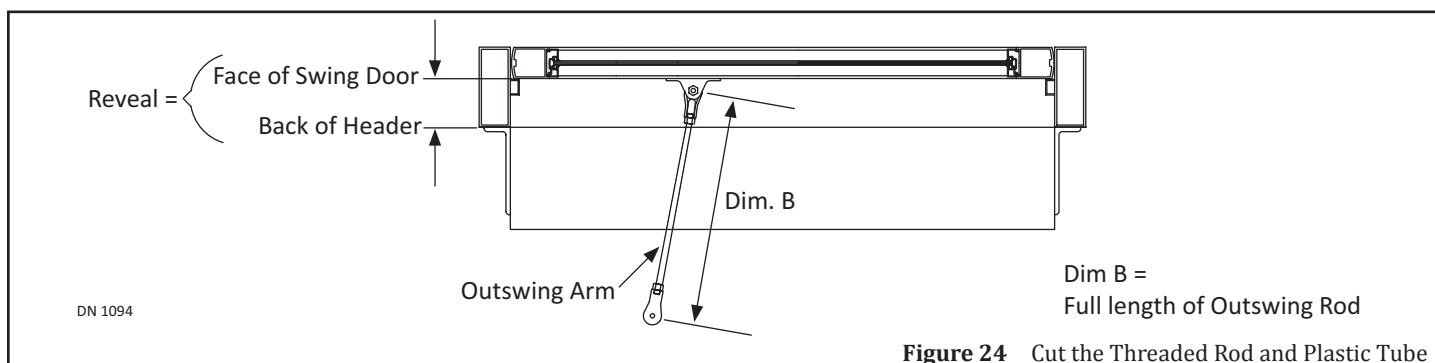

4. Cut the Threaded Rod until the appropriate Full Length measurement is achieved (according to Table 3).
 - a. The Threaded Rod will be approximately 1 inch shorter than the full length measurement.
 - b. For Reveals that are (0 inches thru 6-1/2 inches), a 20 inch Threaded Rod must be purchased.
 - c. For Reveals that are (6-3/4 inches and higher), a 30 inch Threaded Rod must be purchased.
5. Obtain (1) color coordinated Plastic Tube from the Outswing Rod assembly.
6. Cut the Plastic Tube to the same length as the exposed Rod (between the Links and Nuts).
7. Slide the Plastic Tube over the Threaded Rod.
8. Replace the Rod Link back onto the Threaded Rod.
9. Tighten the Nut against the Link to prevent the Rod from screwing In or Out.

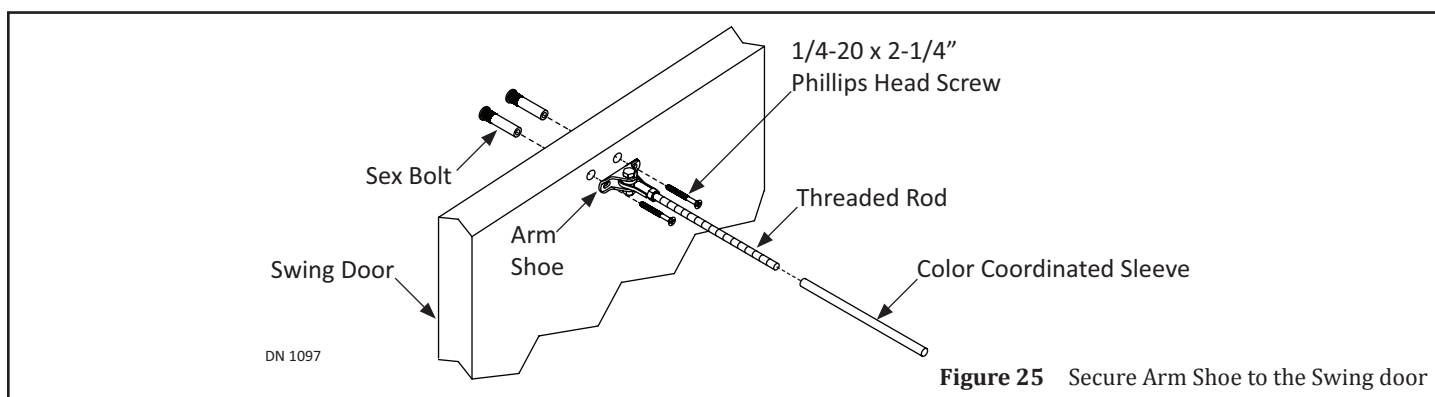

9.1.3 Secure the Arm Shoe to the Swing Door

1. Butt the Arm Shoe against the Swing door. Align the first Sex Bolt hole to the measured Mark.
2. Ensure the Arm Shoe is square and level.
3. Use the Arm Shoe as a Template to mark the second Sex Bolt hole. Set aside.
4. Drill (2) 3/8 inch bolt holes all the way through the Swing door.
5. Go to the back of the Swing door. Insert each Sex Bolt into the drilled holes.
6. Go to the front of the Swing door. Secure the Arm Shoe to the Swing Door with (2) 1/4-20 x 2-1/4" Screws.

9.2 Inswing Arm

Note: Ensure there is a 2 inch gap between the wall and the outside face of the Swing door in the fully opened position (90 degrees) for the Inswing Arm to operate properly.

1. Measure and mark a Horizontal Line from Center Hinge or Butt Offset to the center of the Face of Door according to Table 4.

Table 4 Track Mounting Locations

Model	Pivot Type	Inswing Standard Track (ST) 12-1/4"		Inswing Standard Track (PT) 21"	
		With Fingerguard	No Fingerguard	With Fingerguard	No Fingerguard
GT 400 & 8400	Butt/Offset	N/A	8-1/4"	N/A	N/A
	Center Pivot	13"	12"	3-3/4"	2-3/4"
GT 500 & 8500	Butt/Offset	N/A	8-1/4"	N/A	N/A
	Center Pivot	13-3/4"	12"	3-3/4"	2-3/4"
GT 600 & 8600	Butt/Offset	N/A	8-1/4"	N/A	N/A
	Center Pivot	13"	12"	3-3/4"	2-3/4"

2. Measure:
 - ▶ Straight Arm:
 - 11/16 inch from the Bottom of Door Frame down to the Horizontal Line. Mark a vertical line across the Horizontal Line. This is the center of the first Sex Bolt hole. For Zero Reveal, please refer to Subsubsection 9.2.1 "Zero Reveal".
 - ▶ L-Shape Arm:
 - 1-9/16 inch from the Bottom of Door Frame down to the Horizontal Line.
 - ▶ For dimensions not shown (L-Shape Arm):
 - Reveal + 8-7/8 inch = New dimension

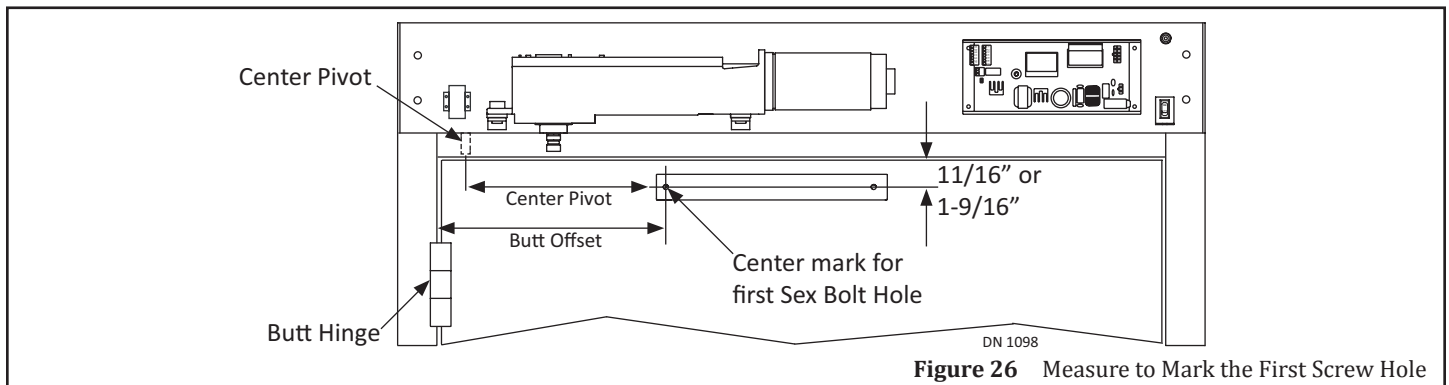
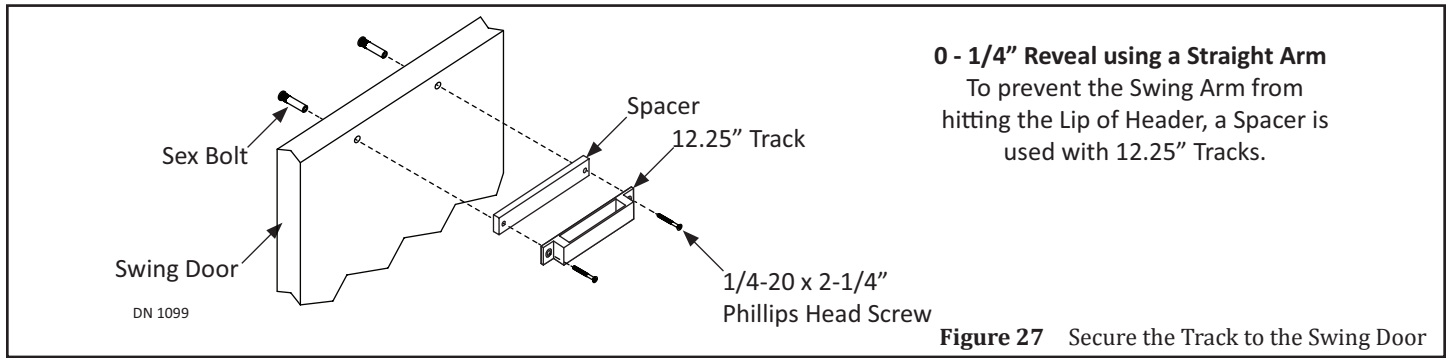
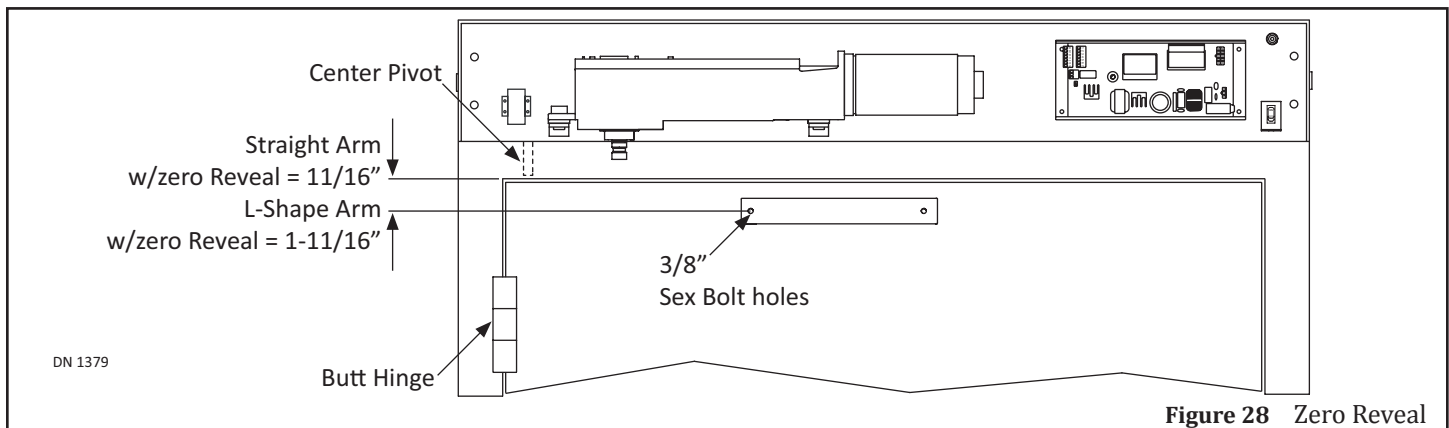

Figure 26 Measure to Mark the First Screw Hole

3. Butt the Track against the Swing door by aligning the first Sex Bolt hole with the measured Mark.
4. Ensure the Track is square and level. Use the Track as a Template to mark the second Sex Bolt hole. Set aside.
5. Drill (2) 3/8 inch bolt holes all the way through the Swing door.
6. Go to the back of the Swing door. Insert each Sex Bolt into the drilled holes.
7. Go to the front of the Swing door. Butt the Track against the Swing door by aligning the Sex Bolt holes.
 - a. Install (1) Spacer behind the Track for Swing doors with "0" Reveal.
8. Secure the Track to the Swing Door with (2) 1/4-20 x 2-1/4" Screw.



9.2.1 Zero Reveal



Note: For zero Reveal applications the Straight Arm can be used to eliminate the Arm protruding into the room.

- ▶ Straight Arm:
 - Measure 11/16 inch from the Bottom of Door Frame down to the Horizontal Line.
- ▶ L-Shape Arm:
 - Measure 1-11/16 inch from the Bottom of Door Frame down to the Horizontal Line.

SECTION 10: INSTALL THE SECOND HALF OF SWING ARM

10.1 Set Pre-Load

WARNING Proper Preload is critical for the Control and Operator to open/close the Swing Door correctly.

CAUTION Power must be turned OFF during the Swing Arm installation.

DANGER Ensure the Motor/Operator is plugged into the Controller. This needs to be done so the Swing Arm will not swing back as fast, if accidentally let go.

Full Energy 400/600/8400/8600	Low Energy 500/8500
20 degrees to 140 degrees	20 degrees to 140 degrees
Not to exceed 15 to 30 pounds of Pressure	Not to exceed 15 pounds of Pressure

1. Ensure the Spring on the Operator is in the Unwound (0°) position.
 - a. The Motor/Operator is shipped in the Unwound (0°) position.

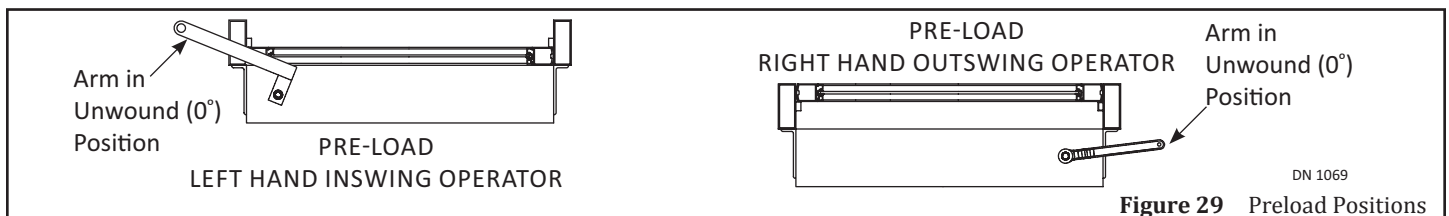

2. Obtain (1) Pin or 1/8 inch Allen Wrench. Go underneath the Header. Locate the Operator Spindle.
3. At the 0 degree position, slide the Swing Arm onto the Spindle.
4. With a firm grip, from the Unwound (0 degree) position, rotate the Swing Arm approximately 20 - 140 degrees.

DANGER

Do not allow the Pin or 1/8 inch Allen Wrench to drop out of the Lovejoy Coupling Access hole at any time during installation. The Swing Arm will spring back to its original location and can result in personal injury or damage.

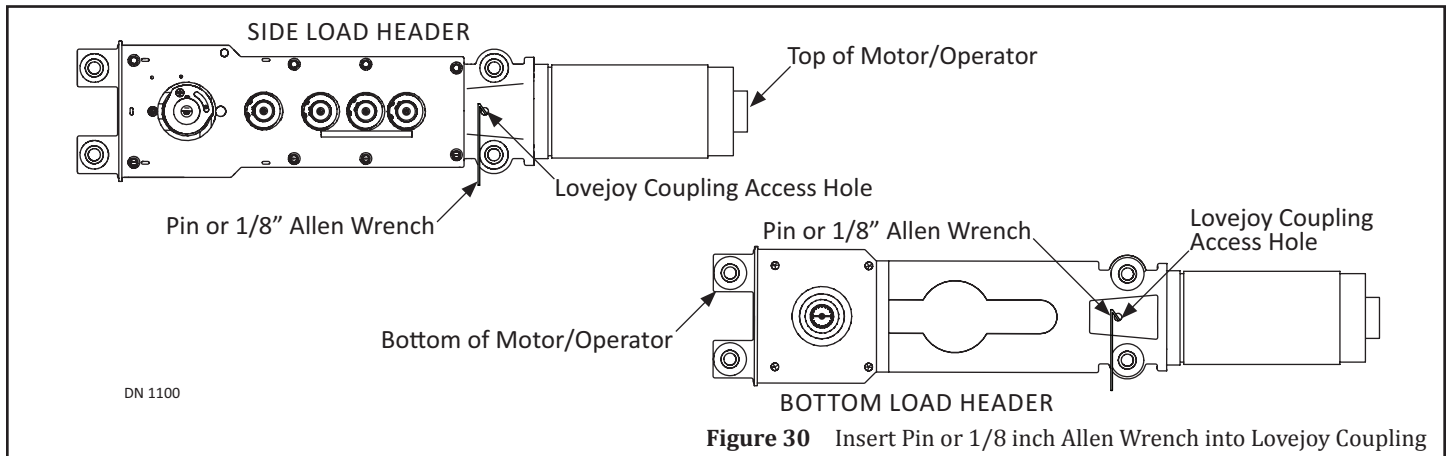

Figure 30 Insert Pin or 1/8 inch Allen Wrench into Lovejoy Coupling

10.2 Secure the Swing Arm to the Swing Door

10.2.1: Outswing Arm

1. Align the Screw hole at the end of Swing Arm to the Screw hole at the end of Threaded Rod.
 - a. It may be necessary to remove and then slide the Swing Arm back onto the Operator Spindle.
2. Secure the Swing Arm to the Threaded Rod with (1) 3/8"-24 x 1-1/4" Socket Screw, (1) .405 Washer, and (1) 3/8"-24 Lock Nut.

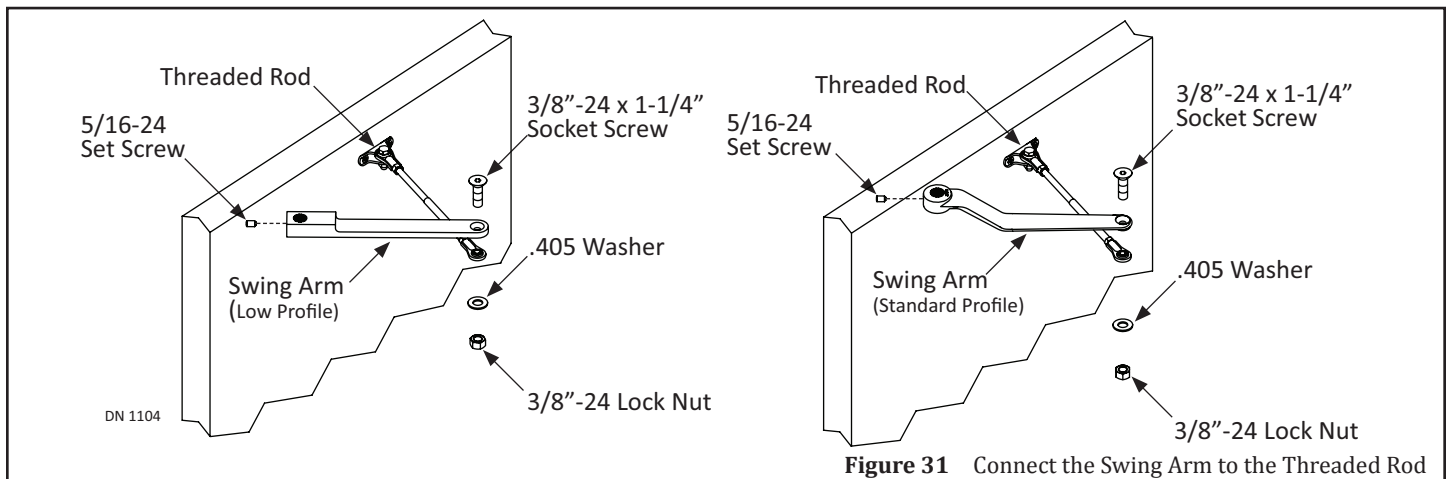

Figure 31 Connect the Swing Arm to the Threaded Rod

10.2.2: Inswing Arm

1. Remove the first 1/4-20 x 2-1/4" Screw (closest to the Pivot Door Jamb) that is used to secure the Track to the Swing door, so that side of the Track will hang down.
2. Close the Swing door to allow the Wheeled Roller (located at the end of the Swing Arm) to butt against the Swing door.
3. Raise the Track until the screw hole is aligned with the screw hole on the Swing door.
 - a. The Wheeled Roller will insert itself into the Track.
4. Secure the Track to the Swing door with (1) 1/4-20 x 2-1/4" Screw.
5. Secure the Swing Arm to the Operator Spindle with (1) Set Screw. Tighten but do not overtighten.
 - a. Ensure the Set Screw is seated correctly within the groove on the Operator Spindle.
6. Remove the (Pin or 1/8 inch) Allen Wrench.

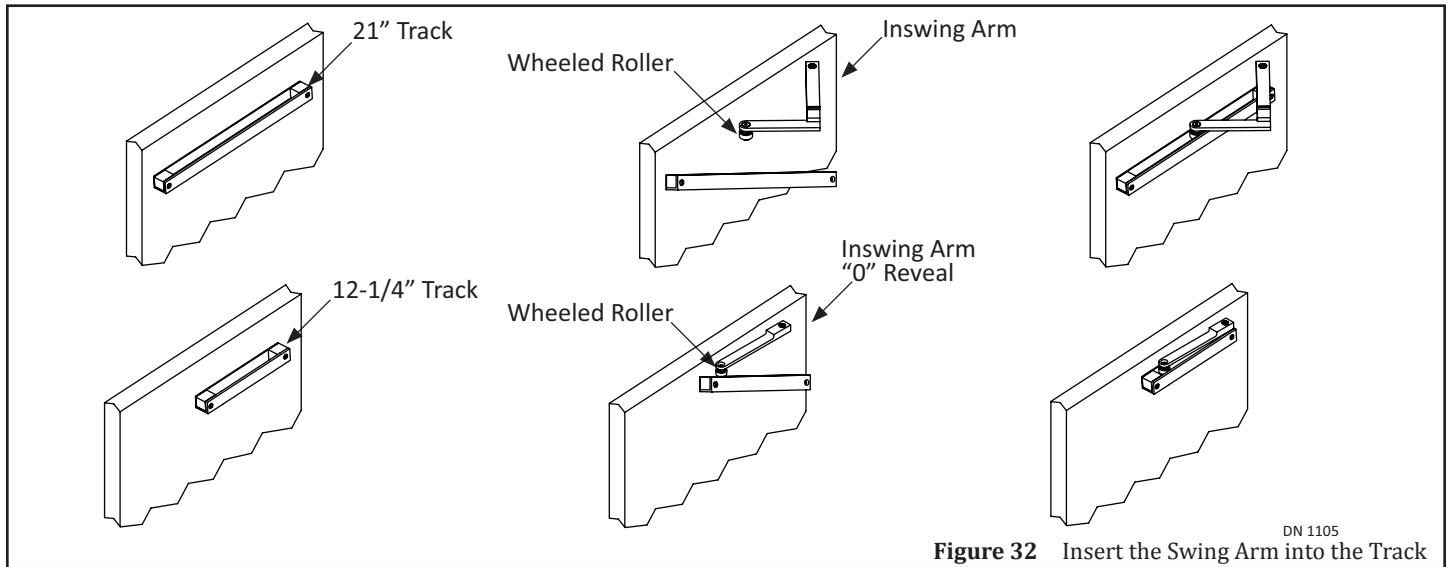

Figure 32 Insert the Swing Arm into the Track DN 1105

SECTION 11: INSTALL THE ARM STOP (SIDE LOAD UNITS)

CAUTION

Do Not drill screw holes for the Arm Stop into the Motor/Operator!!!

1. Open the Swing Door 90 degrees.
2. Obtain the Parts Bag that includes (1) Arm Stop and (2) 1/4-20 inch Self Tapping screws.
3. Position the Arm Stop at the bottom of Header according to type of Swing Arm and Reveal shown in Figure 33.
4. Use the Arm Stop as a template to mark and drill (2) 7/32 inch diameter screw holes.
5. Secure the Arm Stop with (2) 1/4-20 inch Self Tapping screws.

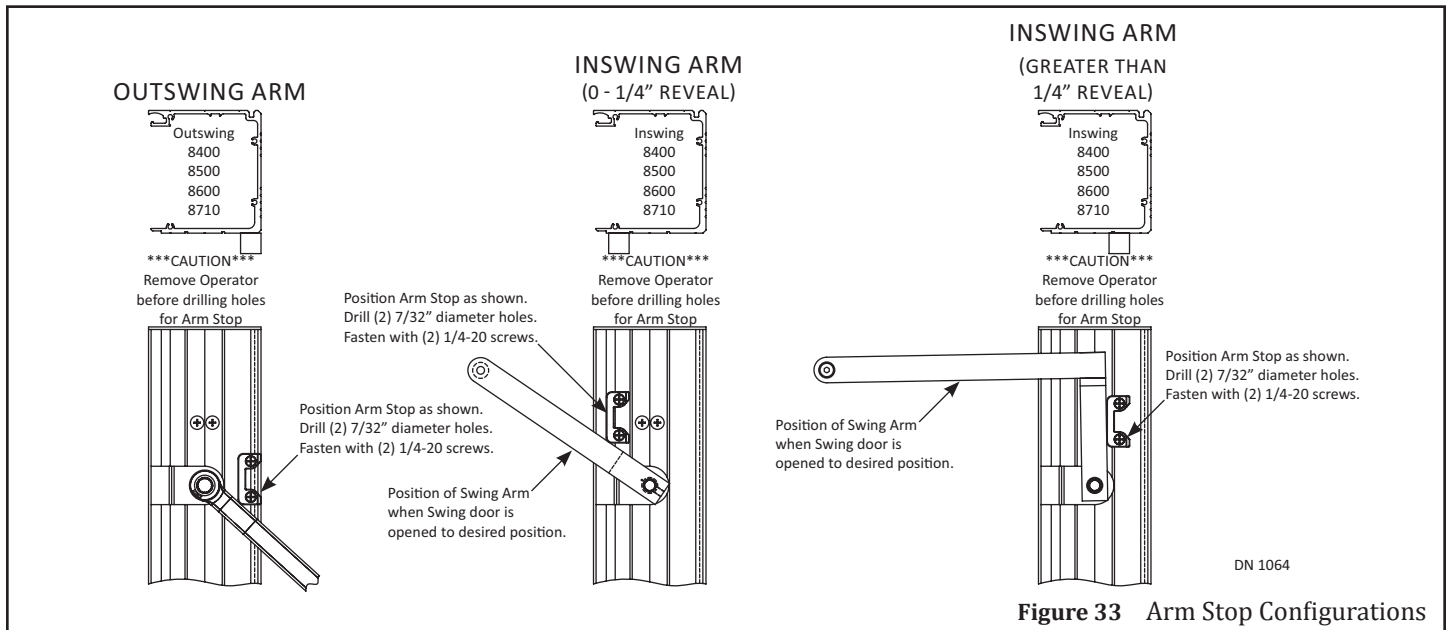
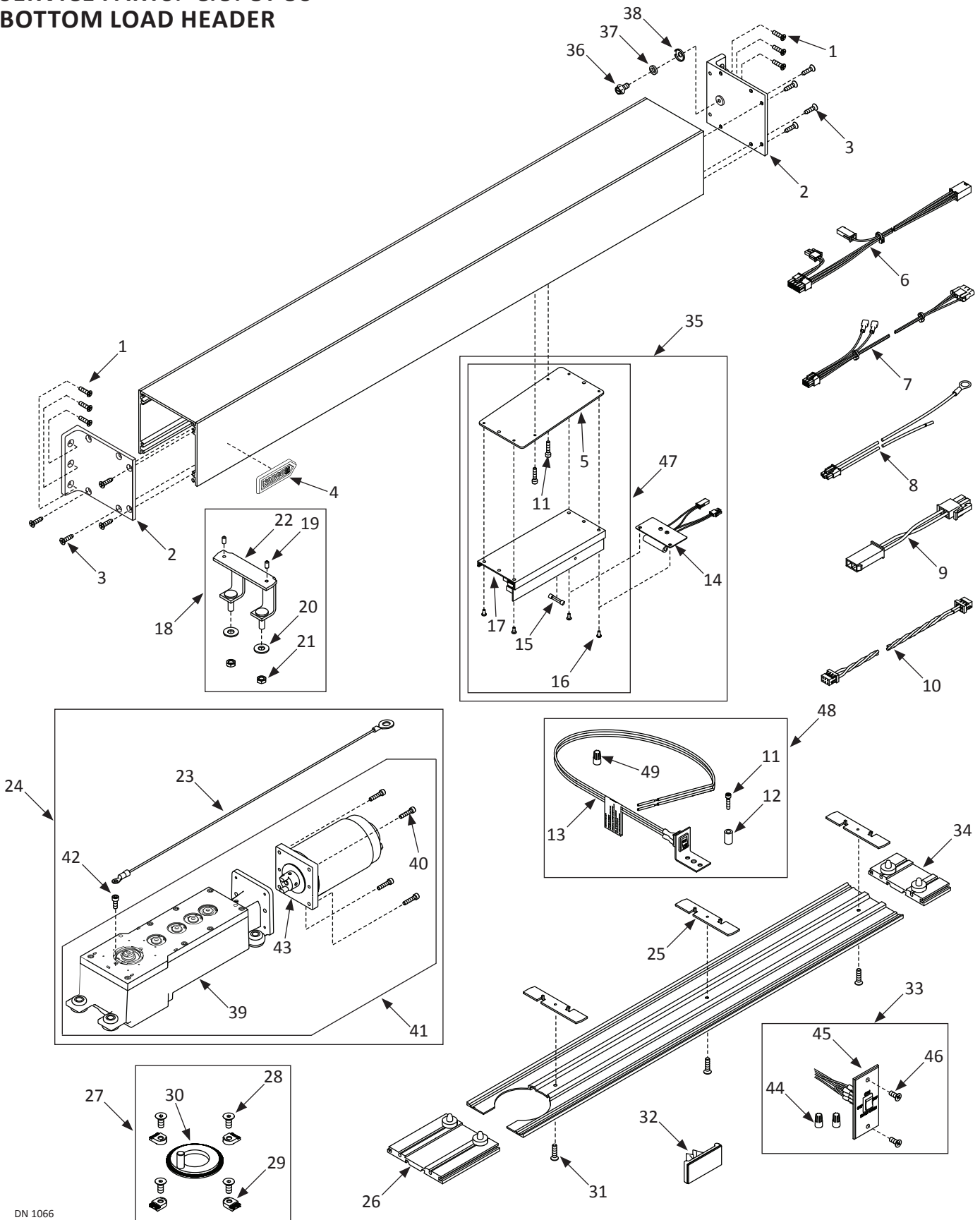

Figure 33 Arm Stop Configurations DN 1064

SERVICE PARTS: C.U. OPUS BOTTOM LOAD HEADER



DN 1066

Opus Bottom Load Header			
Item	Part	Finish/Sizes/Notes	Description
1	T-00294		FHMS,1/4-20x1.000L.,PHIL,ZN
2	A-60733	Clear	"BRACKET,END CAP,C.U.,204"
	A-70733	Dark Bronze	"BRACKET,END CAP,C.U.,313"
3	T-00061		FHMS,1/4-20x1.000L.,PHIL,TRI-LOBE,ZINC
4	C-00067		NAMEPLATE,NABCO LOGO
5	M-01735		PLATE,BOTTOM LOAD,OPUS
6	A-01000	Not used on GT710/8710	HARNESS,MOTOR,OPUS
7	A-01002	Retrofit Kits Only	HARNESS,ADAPTER,NON-ENCODER,OPUS
8	M-01072		HARNESS,POWER,MAGNUM/OPUS
9	A-01001	Not used on GT710/8710	HARNESS,HANDING,OPUS
10	M-01680	Simultaneous Pair	HARNESS,SIM PAIR,OPUS
11	T-00232		SHCS,10-24x0.875L.,ZINC
12	V-00283		SPACER,CIRCUIT BOARD,STANDOFF
13	M-01085		HARNESS, POWER SWITCH - SWINGERS/710
14	A-01003		MODULE,BRAKE,OPUS
15	V-00288	Used on Brake Module	FUSE,3 AMP,250V,FAST,2AG,AXIAL LEAD
	V-00552	Used on Opus Control	FUSE;5A;GMA;5X20mm
16	T-00420		PHMS,8-32x0.375L,PHIL,SWAGEFORM,ZINC
17	M-01546		CONTROLLER,OPUS
18	A-00501		BRKT.;MOTOR;REAR;BTM.LOAD
19	T-00073		SHSS,1/4-20x0.500L.,KNURL PT.
20	T-00092		WASHER,.438 ID,1.00 OD,.083 THK,ZINC
21	T-00067		NUT,HEX,JAM,3/8-16,ZINC
22	M-01181		TOP FRAME MOUNT, SUB - ASSY - SWINGER
23	A-00620		GROUND WIRE:SWING OPERATOR:MAGNUM
24	A-01093	RH	"OPER.SWGR,W/ENCOD,ROF;RH;NO CLUTCH;B-LO
	A-01092	LH	"OPER.SWGR,W/ENCOD.ROF;LH;NO CLUTCH;B-LO
25	M-01177		LOCK COVER PLATE - BOTTOM
26	A-60731	Clear/Out	"BASE PIVOT,C.U.,OUTSWING,204"
	A-70731	Dark Bronze/Out	"BASE PIVOT,C.U.,OUTSWING,313"
	A-60738	Clear/In	"BASE PIVOT,C.U.,IN/OUTSWING,2-1/2,204"
	A-70738	Dark Bronze/In	"BASE PIVOT,C.U.,IN/OUTSWING,2-1/2,313"
27	A-00489		STOP,RING ASSY
28	T-00334		FHMS:5/16-18x0.750L.:SOKT:ZN
29	M-01159		RING, STOP - HOLD DOWN
30	M-01475		LIMIT STOP:C.U.
31	T-00391		"FHMS,10-24x0.750L.,PHIL,ZINC"
32	V-00098		SADDLE, WIRE
33	A-00805		SWITCH,ROCKER,SWINGER,ON/OFF/HOLD OPEN
34	24-0154-01	Clear	CU - SGL STRIKE BASE 3-1/4,204
	24-0154-02	Dark Bronze	CU - SGL STRIKE BASE 3-1/4,313
35	A-01098		CONTROLLER,W/ BRAKE,BOTTOM LOAD,OPUS

Opus Bottom Load Header			
Item	Part	Finish/Sizes/Notes	Description
36	T-00346		HHCS:1/4-20x0.375L:GREEN:WASH HD:SLOT
37	M-00450		SPACER,MTG.END CAP
38	V-00104		WASHER, CUP.312 ID X .88 OD X .040 THICK
39	A-01053	RH	"OPER. SWINGER,W/O MTR.,NO CLUTCH,RH;ROF
	A-01052	LH	"OPER. SWINGER,W/O MTR.,NO CLUTCH,LH;ROF
40	T-00103		"SHCS,10-24x0.875L.,W-LOCK PATCH"
41	A-00824	RH	"OPERATOR,SWGR,W/ENCODER, RH CLUTCHLESS"
	A-00823	LH	"OPERATOR,SWGR,W/ENCODER, LH CLUTCHLESS"
42	T-00185		SHCS,10-24x0.500L.,BK.OX.
43	V-00090		MOTOR,SHORT FRAME,ENCODER,DUOWEI
44	T-00197		NUT,WIRE,RANGE 22-14AWG,GREY
45	M-01576		SWITCHPLATE,ON/OFF/HOLD OPEN
46	T-00031		FHMS,10-32x0.500L.,PHIL,UCUT,T-LOBE,BKZN
47	A-01143		CONTROLLER,W/O BRAKE,BOTTOM LOAD,OPUS
48	A-00409		PARTS BAG,ON/OFF,SWINGER,SWITCH
49	T-00047		NUT,WIRE,72B,2-18AWG-3-16AWG

SERVICE PARTS: C.U. ANALOG BOTTOM LOAD HEADER

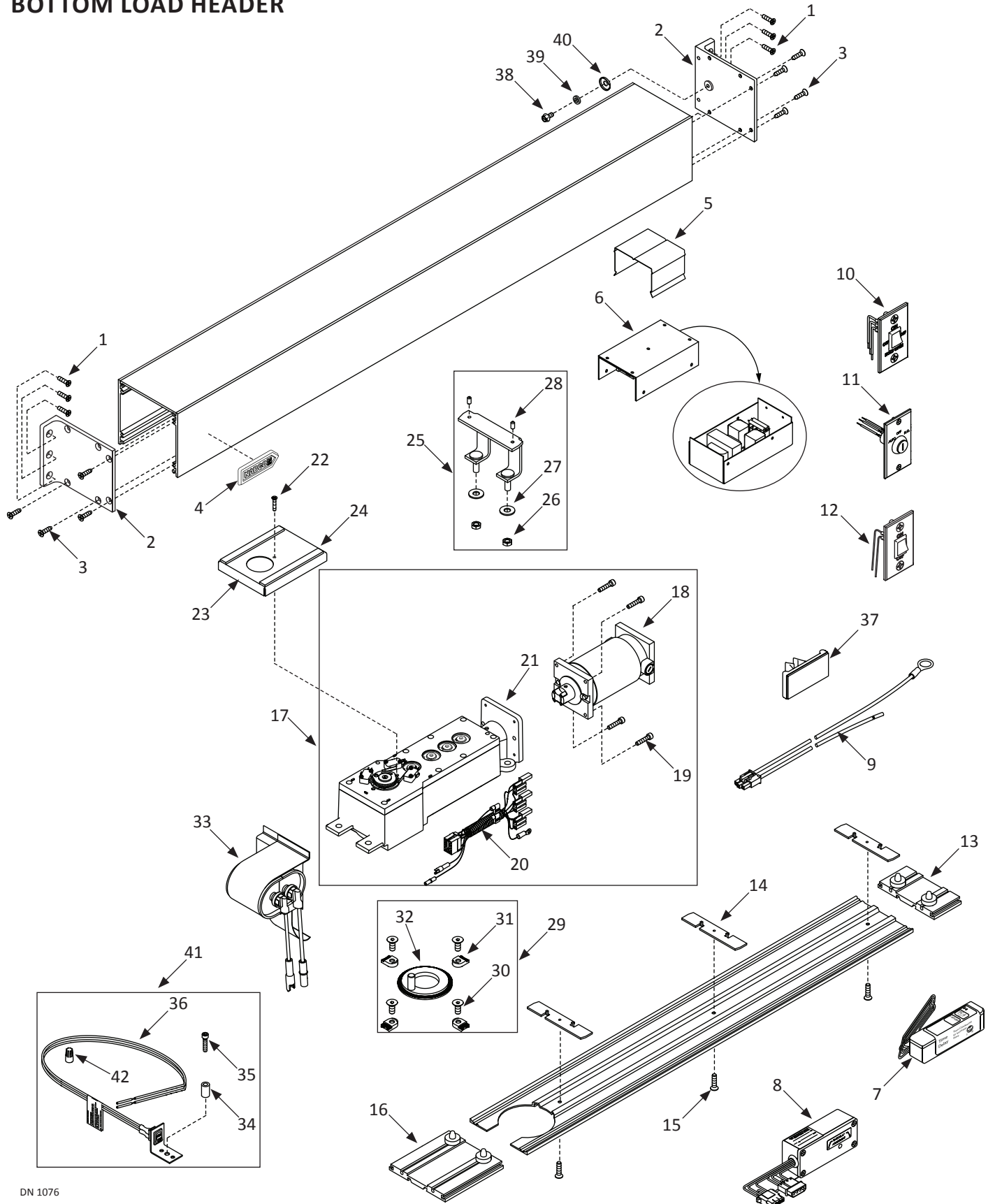

DN 1076

Analog Bottom Load Header			
Item	Part	Finish/Sizes/Notes	Description
1	T-00294		FHMS,1/4-20x1.000L.,PHIL,ZN
2	A-60733	Silver	"BRACKET,END CAP,C.U.,204"
	A-70733	Dark Bronze	"BRACKET,END CAP,C.U.,313"
3	T-00061		FHMS,1/4-20x1.000L.,PHIL,TRI-LOBE,ZINC
4	C-00067		NAMEPLATE,NABCO LOGO
5	M-01040		CONTROL BOX MOUNT
6	M-01457	For GT400/600 Units	CONTROL BOX: 300/400
	A-01007	For GT500 Unit	CONTROL BOX;SLOW MODE OPERATOR
7	V-00245		RELAY,LOCK OUT,PC-6,(USSE KIT #14-11807)
8	A-00592		MODULE:TIME DELAY: ASM W/ CLIP
9	M-01072		HARNES,POWER,MAGNUM/OPUS
10	M-01169		SWITCH,ON/OFF/HOLD ROCKER,GT LOGO
11	A-00552		SWITCH,KEY,KS-14,3 POSITION
12	A-00449		SWITCH,ROCKERLE RS-11,ON/OFF,ASSY W/FPLT
13	24-0154-01	Clear	CU - SGL STRIKE BASE 3-1/4,204
	24-0154-02	Dark Bronze	CU - SGL STRIKE BASE 3-1/4,313
14	M-01177		LOCK COVER PLATE - BOTTOM
15	T-00391		"FHMS,10-24x0.750L.,PHIL,ZINC"
16	A-60731	Clear/Out	"BASE PIVOT,C.U.,OUTSWING,204"
	A-70731	Dark Bronze/Out	"BASE PIVOT,C.U.,OUTSWING,313"
	A-60738	Clear/In	"BASE PIVOT,C.U.,IN/OUTSWING,2-1/2,204"
	A-70738	Dark Bronze/In	"BASE PIVOT,C.U.,IN/OUTSWING,2-1/2,313"
17	A-00699	LH	"OPERATOR,SWINGER,LH,ANALOG"
	A-00698	RH	"OPERATOR,SWINGER,RH,ANALOG"
18	A-00347		MOTOR AND COUPLER
19	T-00103		"SHCS,10-24x0.875L.,W-LOCK PATCH"
20	A-00352		HARNES,THREE SWITCH OPERATOR
21	A-01053	RH	"OPER. SWINGER,W/O MTR.,NO CLUTCH,RH;ROF
	A-01052	LH	"OPER. SWINGER,W/O MTR.,NO CLUTCH,LH;ROF
22	T-00238		FHMS,10-24x1.000L.,PHIL,ZINC
23	A-00348		COVER,SWITCH,SWINGER
24	M-01018		BUMPON STRIP
25	A-00501		BRKT.;MOTOR;REAR;BTM.LOAD
26	T-00067		NUT,HEX,JAM,3/8-16,ZINC
27	T-00092		WASHER,.438 ID,1.00 OD,.083 THK,ZINC
28	T-00073		SHSS,1/4-20x0.500L.,KNURL PT.
29	A-00489		STOP,RING ASSY
30	T-00334		FHMS:5/16-18x0.750L.:SOKT:ZN
31	M-01159		RING, STOP - HOLD DOWN
32	M-01475		LIMIT STOP:C.U.
33	A-00737	30 MF	"SOFT START KIT,SWINGER"
	A-00955	15 MF	"SUPER SOFT START KIT,SWINGER"

Analog Bottom Load Header

Item	Part	Finish/Sizes/Notes	Description
34	V-00283		SPACER,CIRCUIT BOARD,STANDOFF
35	T-00232		SHCS,10-24x0.875L.,ZINC
36	M-01085		HARNESS, POWER SWITCH - SWINGERS/710
37	V-00098		SADDLE, WIRE
38	T-00346		HHCS:1/4-20x0.375L:GREEN:WASH HD:SLOT
39	M-00450		SPACER,MTG.END CAP
40	V-00104		WASHER, CUP.312 ID X .88 OD X .040 THICK
41	A-00409		PARTS BAG,ON/OFF,SWINGER,SWITCH
42	T-00047		NUT,WIRE,72B,2-18AWG-3-16AWG

SERVICE PARTS: C.U. OPUS SIDE LOAD HEADER

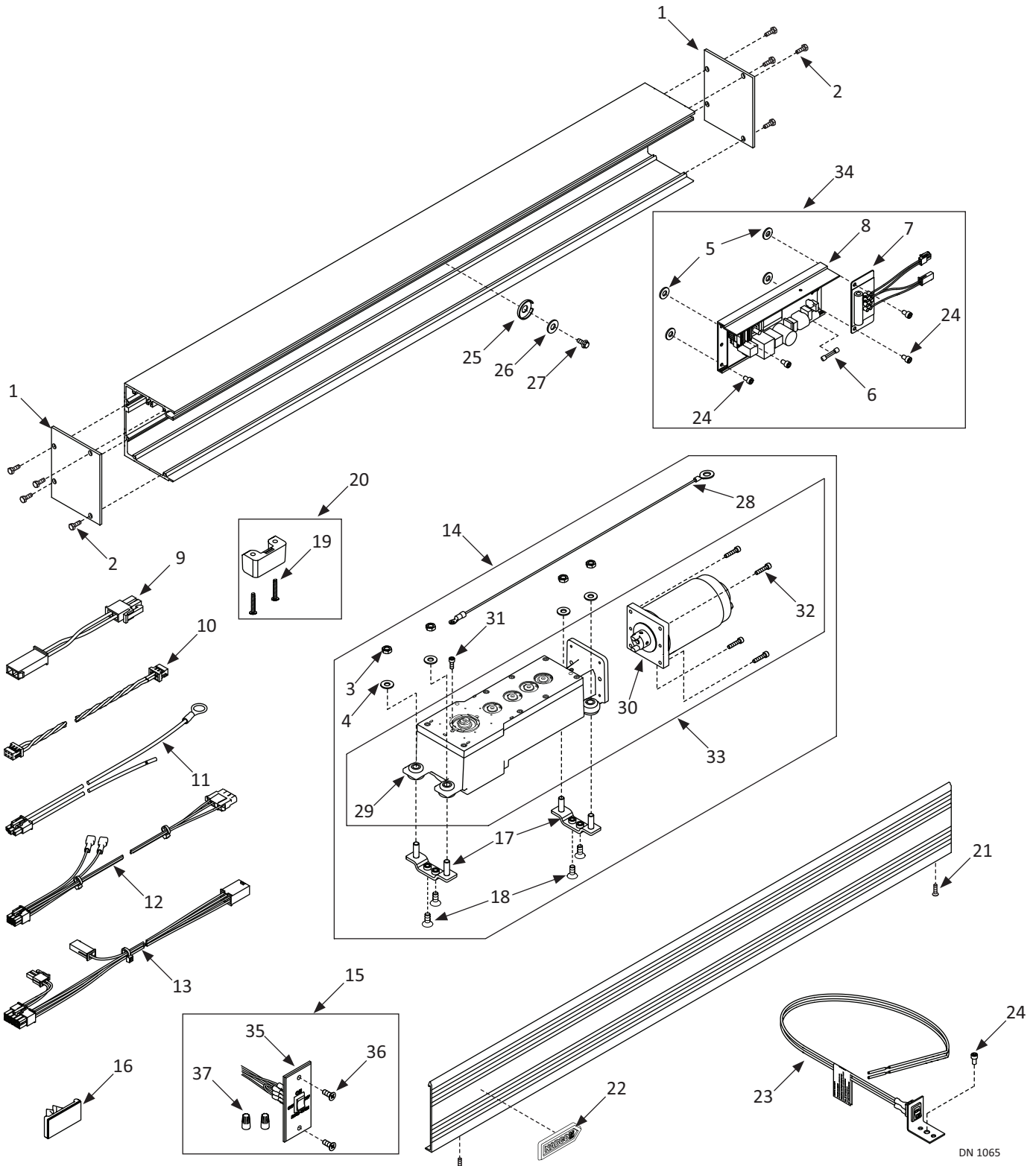

Opus Side Load Header			
Item	Part	Finish/Sizes/Notes	Description
1	M-01051	Clear	END CAP,SIDELOAD HDR,84-8500 4HOLE,204
	M-71051	Dark Bronze	END CAP,SIDELOAD,NO ACCESS HOLE,313
2	T-00016	Clear	FHMS,1/4-20x0.438L.,PHIL,UNDERCUT,ZINC
	T-00108	Dark Bronze	FHMS,1/4-20x0.438L.,PHIL,UNDERCUT,BLK ZN
3	T-00067		NUT,HEX,JAM,3/8-16,ZINC
4	T-00092		WASHER,.438 ID,1.00 OD,.083 THK,ZINC
5	T-00365		WASHER,.170 ID,.625 OD,.032 THK,NYLON
6	V-00288		FUSE,3 AMP,250V,FAST,2AG,AXIAL LEAD
	V-00552		FUSE;5A;GMA;5X20mm
7	A-01003		MODULE,BRAKE,OPUS
8	M-01546		CONTROLLER,OPUS
9	A-01001	Not used on GT710/8710	HARNESS,HANDING,OPUS
10	M-01680	Simultaneous Pair	HARNESS,SIM PAIR,OPUS
11	M-01072		HARNESS,POWER,MAGNUM/OPUS
12	A-01002	Retrofit Kits Only	HARNESS,ADAPTER,NON-ENCODER,OPUS
13	A-01000	Not used on GT710/8710	HARNESS,MOTOR,OPUS
14	A-01091	RH	"OPER.SWGR,W/ENCOD,ROF;RH;NO CLUTCH;S-LO
	A-01090	LH	"OPER.SWGR,W/ENCOD.ROF;LH;NO CLUTCH;S-LO
15	A-00805		SWITCH,ROCKER,SWINGER,ON/OFF/HOLD OPEN
16	V-00098		SADDLE, WIRE
17	M-01043		BRACKET, OPERATOR, SIDELOAD HEADER
18	T-00334	Clear	FHMS:5/16-18x0.750L.:SOKT:ZN
	T-00370	Dark Bronze	FHMS:5/16-18x0.750L.:SOKT:BK.ZN
19	T-00325		PHMS, 1/4-20X1.500L, PHIL, TYPE F
20	A-00454		ARM STOP,ASSEM FOR 400, 8400, 500, 8500
21	T-00337		PHSMS:#8x0.625L.:PHIL
22	C-00067		NAMEPLATE,NABCO LOGO
23	M-01085		HARNESS, POWER SWITCH - SWINGERS/710
24	T-00335		SHCS,10-24x0.313L.,ZINC
25	V-00104		WASHER, CUP.312 ID X .88 OD X .040 THICK
26	T-00029		WASHER,.250 ID,.563 OD,.049 THK,ZINC
27	T-00347		HHCS:10-32x0.375L:GREEN:WASH HD:SLOT
28	A-00620		GROUND WIRE:SWING OPERATOR:MAGNUM
29	A-01053	RH	"OPER. SWINGER,W/O MTR.,NO CLUTCH,RH;ROF
	A-01052	LH	"OPER. SWINGER,W/O MTR.,NO CLUTCH,LH;ROF
30	V-00090		MOTOR,SHORT FRAME,ENCODER,DUOWEI
31	T-00185		SHCS,10-24x0.500L.,BK.OX.
32	T-00103		"SHCS,10-24x0.875L.,W-LOCK PATCH"
33	A-00824	RH	"OPERATOR,SWGR,W/ENCODER, RH CLUTCHLESS"
	A-00823	LH	"OPERATOR,SWGR,W/ENCODER, LH CLUTCHLESS"
34	A-00888		CONTROLLER,W/ BRAKE,SIDELOAD,OPUS
35	M-01576		SWITCHPLATE,ON/OFF/HOLD OPEN

Opus Side Load Header			
Item	Part	Finish/Sizes/Notes	Description
36	T-00031		FHMS,10-32x0.500L.,PHIL,UCUT,T-LOBE,BKZN
37	T-00197		NUT,WIRE,RANGE 22-14AWG,GREY

SERVICE PARTS: C.U. ANALOG SIDE LOAD HEADER

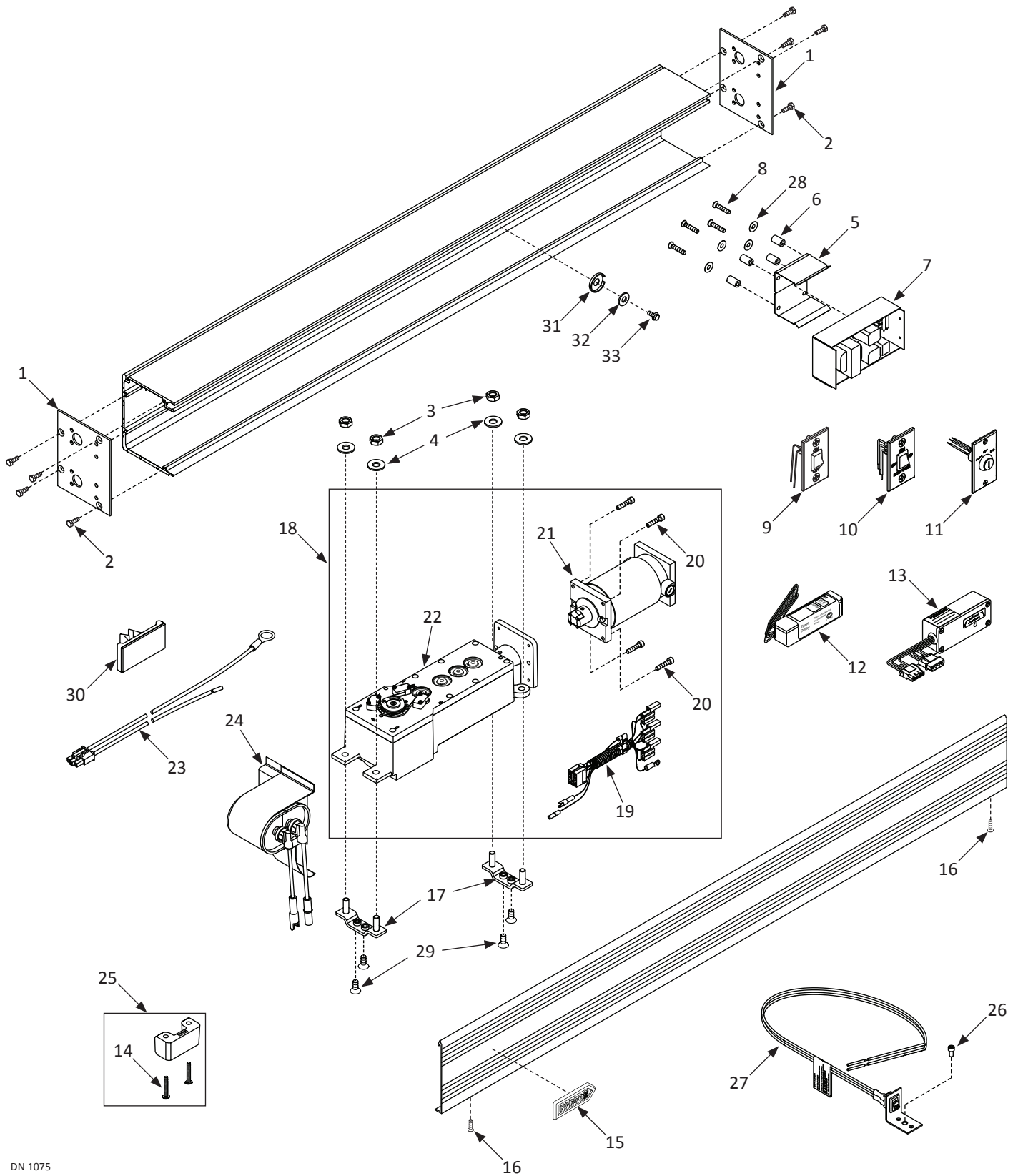

DN 1075

Analog Side Load Header			
Item	Part	Finish/Sizes/Notes	Description
1	M-01051	Clear	END CAP,SIDELOAD HDR,84-8500 4HOLE,204
	M-71051	Dark Bronze	END CAP,SIDELOAD,NO ACCESS HOLE,313
2	T-00016	Zinc	FHMS,1/4-20x0.438L.,PHIL,UNDERCUT,ZINC
	T-00108	Black Onix	FHMS,1/4-20x0.438L.,PHIL,UNDERCUT,BLK ZN
3	T-00067		NUT,HEX,JAM,3/8-16,ZINC
4	T-00092		WASHER,.438 ID,1.00 OD,.083 THK,ZINC
5	A-00957		CONTROL BOX MOUNT
6	V-00283		SPACER,CIRCUIT BOARD,STANDOFF
7	M-01457	For GT400/600 Units	CONTROL BOX: 300/400
	A-01007	For 500 Unit	CONTROL BOX;SLOW MODE OPERATOR
8	T-00238		FHMS,10-24x1.000L.,PHIL,ZINC
9	A-00449		SWITCH,ROCKERLE RS-11,ON/OFF,ASSY W/FPLT
10	M-01169		SWITCH,ON/OFF/HOLD ROCKER,GT LOGO
11	A-00552		SWITCH,KEY,KS-14,3 POSITION
12	V-00245		RELAY,LOCK OUT,PC-6,(USSE KIT #14-11807)
13	A-00592		MODULE:TIME DELAY: ASM W/ CLIP
14	T-00325		PHMS, 1/4-20X1.500L, PHIL, TYPE F
15	C-00067		NAMEPLATE,NABCO LOGO
16	T-00337		PHSMS:#8x0.625L.:PHIL
17	M-01043		BRACKET, OPERATOR, SIDELOAD HEADER
18	A-00698	RH	"OPERATOR,SWINGER,RH,ANALOG"
	A-00699	LH	"OPERATOR,SWINGER,LH,ANALOG"
19	A-00352		HARNESSTHREE SWITCH OPERATOR
20	T-00103		"SHCS,10-24x0.875L.,W-LOCK PATCH"
21	A-00347		MOTOR AND COUPLER
22	A-01053	RH	"OPER. SWINGER,W/O MTR.,NO CLUTCH,RH;ROF
	A-01052	LH	"OPER. SWINGER,W/O MTR.,NO CLUTCH,LH;ROF
23	M-01072		HARNESSTHREE SWITCH OPERATOR
24	A-00737	30 MF	"SOFT START KIT,SWINGER"
	A-00955	15 MF	SUPER SOFT START KIT, 15 MF
25	A-00454		ARM STOP,ASSEM FOR 400, 8400, 500, 8500
26	T-00232		SHCS,10-24x0.875L.,ZINC
27	M-01085		HARNESSTHREE SWITCH OPERATOR
28	T-00365		WASHER,.170 ID,.625 OD,.032 THK,NYLON
29	T-00334	Clear	FHMS:5/16-18x0.750L.:SOKT:ZN
	T-00370	Dark Bronze	FHMS:5/16-18x0.750L.:SOKT:BK.ZN
30	V-00098		SADDLE, WIRE
31	V-00104		WASHER, CUP.312 ID X .88 OD X .040 THICK
32	T-00029		WASHER,.250 ID,.563 OD,.049 THK,ZINC
33	T-00347		HHCS:10-32x0.375L:GREEN:WASH HD:SLOT

SERVICE PARTS: SWING ARM ASSEMBLIES

Inswing Arm
Reveal **Equal** to 0 degrees

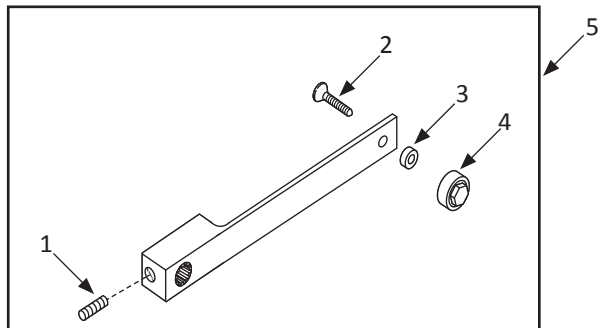

Outswing Arm Assembly

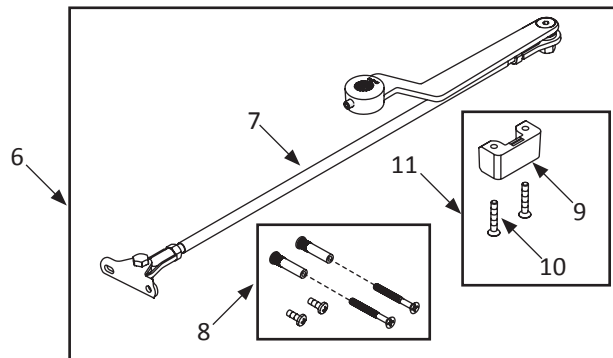

(CU) Inswing Arm Assembly
Reveal Greater than 0 inches

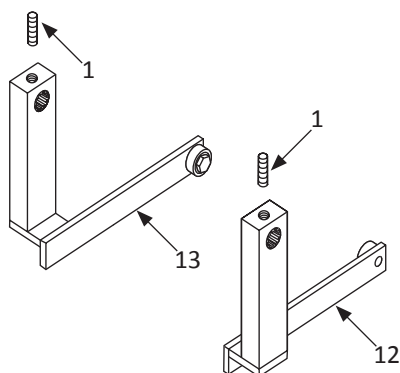

Low Profile
Outswing Arm Assembly

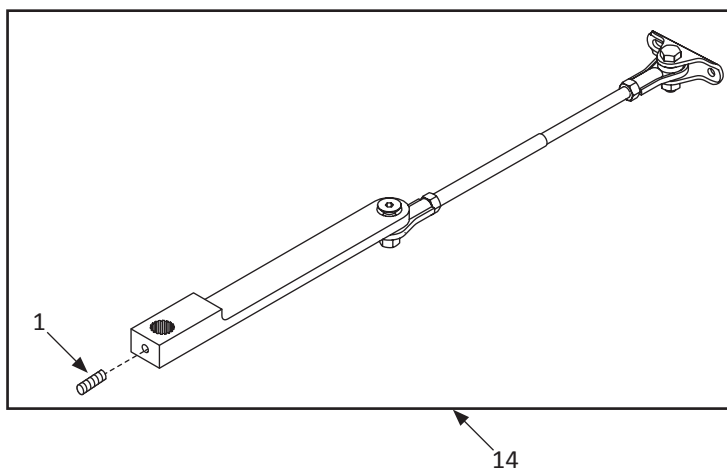

Inswing Track Assembly (12.25 inch)

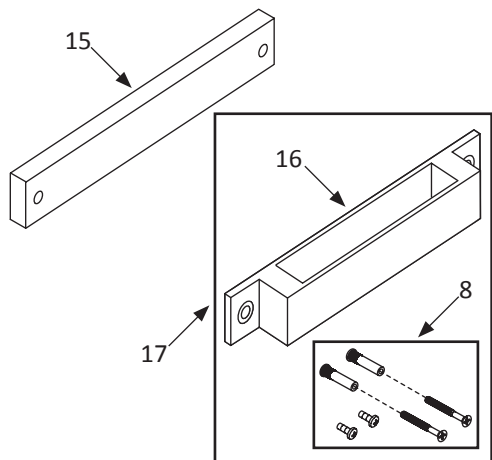

Inswing Track Assembly (21 inch)

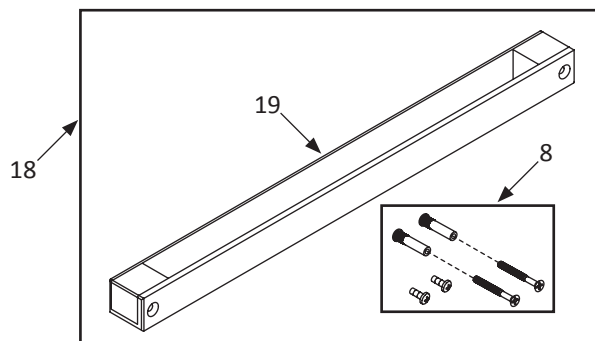

Swing Arm Assemblies			
Item	Part	Finish/Sizes/Notes	Description
1	T-00261		SHSS,5/16-24x0.500L.,CUP PT.
2	T-00223		FHCS,3/8-24x1.250L.,ZINC
3	M-01045		WASHER,STEEL,.375IDx.750Dx.375THK.
4	A-00752		"ROLLER,REPLACEMENT"
5	A-60545	Clear	"ARM,INSWING,CU,NON PANIC,NH,204"
	A-70545	Dark Bronze	ARM,INSWING CU,NO PANIC,NH 313
6	A-60786	Clear	"ARM,OUTSWING,CU.,20in,204,W-STOP"
	A-70786	Dark Bronze	"ARM,OUTSWING,CU.,20in,313,W-STOP"
	A-60787	Clear	"ARM,OUTSWING,,C.U.,30in,204,W-STOP"
	A-70787	Dark Bronze	"ARM,OUTSWING,CU.,30in,313,W-STOP"
7	A-60425	Clear	"ARM,OUTSWING,STD ASM,20in,204"
	A-70425	Dark Bronze	ARM:OUTSWING:STD ASM:20":313
	A-60426	Clear	"ARM,OUTSWING,STD ASM,30in,204"
	A-70426	Dark Bronze	ARM:OUTSWING:STD ASM:30":313
8	A-00389	Clear	PARTS BAG,SEX BOLTS & HARDWARE,204
	A-00388	Dark Bronze	PARTS BAG,SEX BOLTS & HARDWARE,313
9	M-01080		ARM STOP, 710
10	T-00325		PHMS, 1/4-20X1.500L, PHIL, TYPE F
11	A-00471		KIT, GT710 PARTS
12	A-60658	RH/Clear	"INSWING ARM,0 TO 2 REV,RH,204"
	A-70658	RH/Dark Bronze	INSWING ARM:7-3/4:RH:313
	A-60671	RH/Clear	"INSWING ARM,2 TO 5-1/2 REV,RH,204"
	A-70671	RH/Dark Bronze	INSWING ARM:11-1/2:RH:313
	A-60672	RH/Clear	"INSWING ARM5-1/2 TO 9-3/4 REV,RH,204"
	A-70672	RH/Dark Bronze	INSWING ARM:15-3/4:RH:313
	A-60673	RH/Clear	"INSWING ARM,9-3/4 TO 13 REV,RH,204"
	A-70673	RH/Dark Bronze	INSWING ARM:20-1/2:RH:313
13	A-60675	LH/Clear	"INSWING ARM,0 TO 2 REV,LH,204"
	A-70675	LH/Dark Bronze	INSWING ARM:7-3/4:LH:313
	A-60676	LH/Clear	"INSWING ARM,2 TO 5-1/2 REV,LH,204"
	A-70676	LH/Dark Bronze	INSWING ARM:11-1/2:LH:313
	A-60677	LH/Clear	"INSWING ARM,5-1/2 TO 9-3/4,LH,204"
	A-70677	LH/Dark Bronze	INSWING ARM:15-3/4:LH:313
	A-60678	LH/Clear	"INSWING ARM,9-3/4 TO 13 REV,LH,204"
	A-70678	LH/Dark Bronze	INSWING ARM:20-1/2:LH:313
14	A-60770	Clear	"ARM,OUTSWING,CU,20IN,204"
	A-70770	Dark Bronze	"ARM,OUTSWING,CU.20IN.313"
	A-60771	Clear	"ARM,OUTSWING,CU,30IN.204"
	A-70771	Dark Bronze	"ARM,OUTSWING,CU,30IN.313"
15	A-00952		SPACER, INSWING TRACK
16	A-60536	Clear	"GUIDE TRACK,C.U.,12.25L,204"
	A-70536	Dark Bronze	GUIDE TRACK,C.U.,SUB-ASSY,12.25"

Swing Arm Assemblies			
Item	Part	Finish/Sizes/Notes	Description
17	A-60639	Long/Clear	"TRACK,INSWING,10,204"
	A-70639	Long/Dark Bronze	"TRACK,INSWING,10,313"
18	A-00481	Clear	TRACK,INSWING,21 LG,204
	A-70481	Dark Bronze	TRACK,INSWING,21 LG,313
19	A-60435	Clear	"C.U. GUIDE TRACK,21.0L,204"
	A-70435	Dark Bronze	C.U. GUIDE TRACK,21.0L,313