



NABCO ENTRANCES Inc.
S82 W18717 Gemini Drive
Muskego, WI 53150
Phone: 877-622-2694
Fax: 888-679-3319
Technical Support: 866-622-8325
www.nabcoentrances.com

Analog Control

Wiring & Adjustment Manual

for

Gyro Tech Swing Door Operators

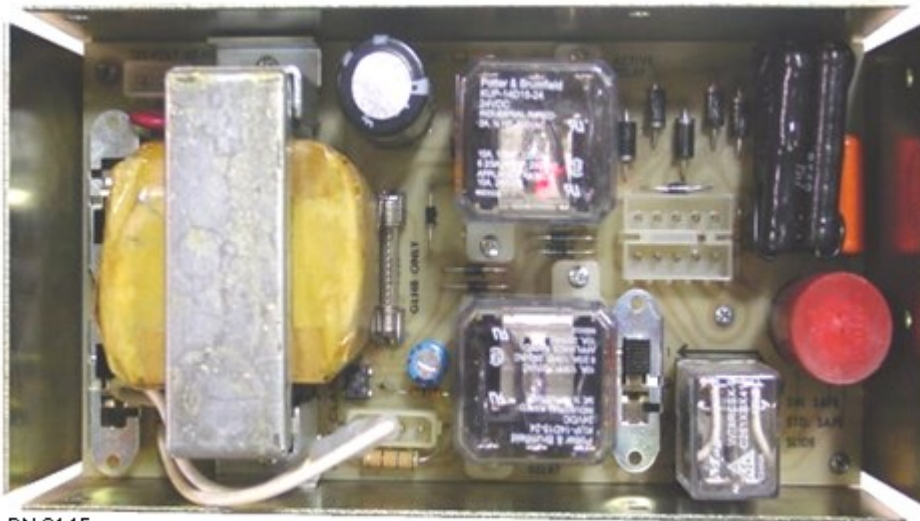

DN 0145

WARNING

Turn OFF all power to the Automatic Door if a Safety System is not working.

Instruct the Owner to keep all power turned OFF until corrective action can be achieved by a NABCO trained technician. Failure to follow these practices may result in serious consequences.

NEVER leave a Door operating without all Safety detection systems operational.

Part Number 15-10745
Rev 8-13-09

CAUTION

Read these safety practices before installing, operating or servicing the automatic door. Failure to follow these practices may result in serious consequences.

Read, study and understand the operating instructions contained in or referenced in this manual before operating. If you do not understand the instruction, ask the installing qualified technician to teach you how to use the door.

This manual and the owners' manual must be given to and retained by the purchasing facility or end user.

If the door appears broken or does not seem to work correctly, it should be immediately removed from service and a qualified service technician contacted for corrective action.

Disconnect power at the fused disconnect during all electrical or mechanical service. When uncertain whether power supply is disconnected, always verify using a voltmeter.

All electrical troubleshooting or service must be performed by qualified electrical technicians and must comply with all applicable governing agency codes.

It is the responsibility of the installing door technician to install all warning and instructional labels in accordance with the applicable ANSI standard.

It is the responsibility of the purchasing facility or end user to keep warning and instructional labels and literature legible, intact and with the door.

Replacement labels and literature may be obtained from local NABCO ENTRANCES INC. authorized distributors. If the name of the local distributor is unknown, contact NABCO ENTRANCES INC. at (877-622-2694) for assistance.

Do not place finger or uninsulated tools inside the electrical control box. Touching wires or other parts inside the enclosure may cause electrical shock, serious injury or death.

All adjustments should be made with a small screwdriver. DO NOT use a pencil.

The ground wire from the Magnum 120 VAC harness and the ground wire from the 120 VAC "in" line must be attached to the ground screw which is located in the header.

Final installation must conform to current versions of ANSI 156.19 for Low Energy swingers or ANSI 156.10 for Full Automatic Installations.

Table of Contents

To The Installer	Page 4
Overview	Page 4
Specifications	Page 4
Analog Control Components	Page 5
Wiring Connectors	Page 6
Door Positions	Page 6
Terminology	Page 6
Adjustments	Page 6
Micro switch Adjustments	Page 7
Wiring for Rocker switch	Page 7
Wiring for Panic Break-out	Page 8
Required Wiring Harnesses	Page 9
Section A - Sample Wiring Diagrams for GT-300, GT-400 Full Automatic Installations	Page 10
Figure 7 - General Wiring - GT-300/400 Single Outswing	Page 11
Figure 8 - General Wiring - GT-300/400 Single Inswing	Page 12
Figure 9 - General Wiring – GT-300/400 Pair Outswing	Page 13
Figure 10 - General Wiring – GT-300/400 Pair Inswing	Page 14
Section B - Sample Wiring Diagrams for GT-500 Low Energy Installations	Page 15
Figure 11 - General Wiring - GT-500 Single Outswing	Page 16
Figure 12 - General Wiring - GT-500 Single Inswing	Page 17
Figure 13 - General Wiring – GT-500 Pair Outswing	Page 18
Figure 14 - General Wiring – GT-500 Pair Inswing	Page 19
Figure 15 - GT-500 with Electric Lock & Sequencer	Page 20
Troubleshooting	Page 21
Troubleshooting	Page 22

To The Installer

The purpose of this manual is to familiarize the purchaser with the proper installation and operation of this system. It is essential that this equipment be properly installed and operational before the door is used by the public. It is the purchaser's responsibility to inspect the operation of the entrance system to be sure it complies with any applicable standards. In the United States, ANSI Standard 156.19 usually covers this type of door. Other local standards or codes may apply. Use them in addition to the ANSI Standard.

Instruct the building owners/operator on the essentials of the operation of the door and this device. The owner should follow these instructions to determine whether the door is operating properly and should immediately call for service if there is any malfunction.

All installation changes and adjustments must be made by qualified, NABCO trained technicians.

Overview

Some features of the Analog Control:

- A. One safety input with slide switch to select safety modes:
 - 1. Standard Safe - Safety is ignored during opening cycle only
 - 2. Swing Safe - Safety is never ignored
 - 3. Slide - DO NOT USE
- D. Push-N-Go module available as an option (GT-500 Standard Mode only)
- E. Open speed slide switch
- F. Check speed slide switch
- G. 24 VAC 0.25 Amp output for auxiliary devices

Specifications:

Power Input	120 VAC (±10%) AC 50-60 Hz, 5 Amps
Available Output for Accessories	0.25 Amps 24 Volts AC
Available Wire Size for Incoming Power	14 AWG
Fuses	1 x 120 VAC, BUSS GLH-8
Thermo-Couple	Automatic cutoff of motor if overheated
Activation Hold Time	Adjustable 0-60 seconds (with optional time delay module)

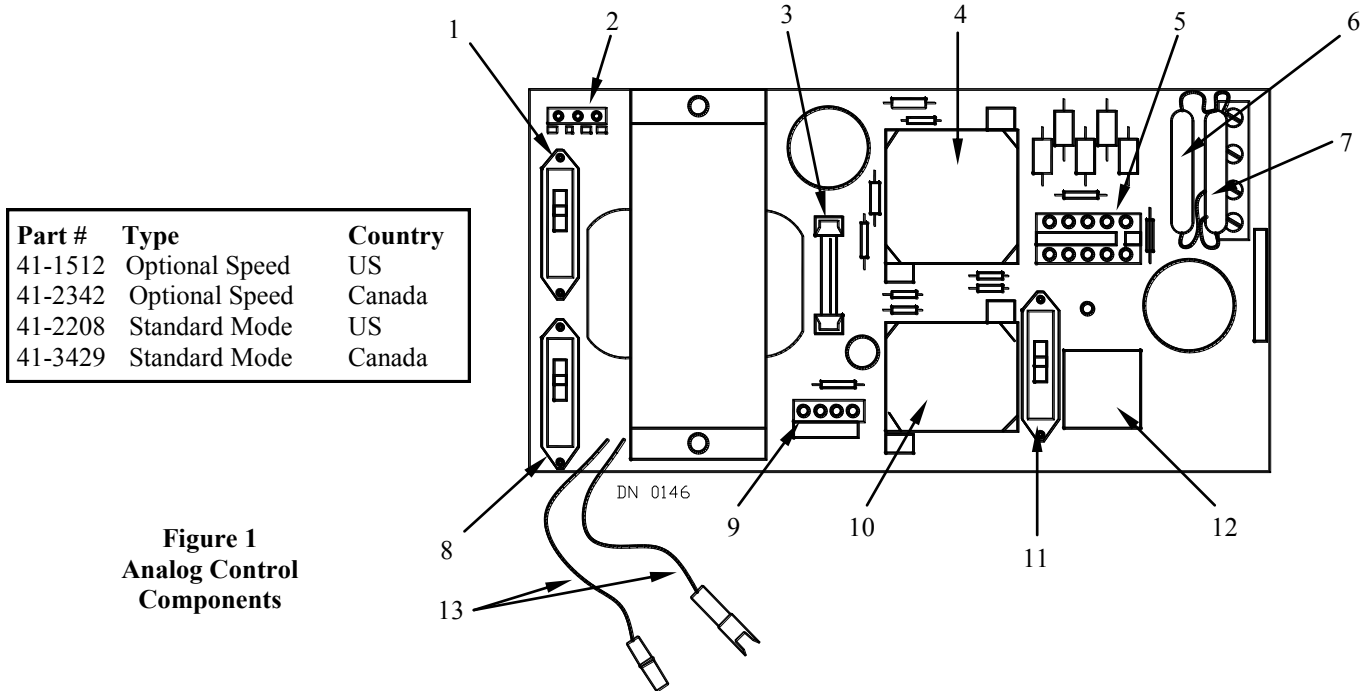

ITEM	DESCRIPTION	USE	NOTES:
1	OPEN Speed Switch	Vary the opening speed	Fast position toward center of control
2	120 VAC Connector	Supply 120 VAC to control and equipment	
3	Fuse	Main fuse for control	BUSS GLH-8
4	Activate Relay	Relay responsible for switching voltage to motor	
5	Operator Switch Harness Connector	Used to connect the motor and operator micro switch circuit to the control	Model 850 Lockout (when used) also connects here
6	Closing Resistor	Governs closing speed of door. Resistor located on terminals 1 & 3 of terminal block. Terminal 1 being closest to edge of control.	Value of resistor governs closing speed. Higher value speeds up door. Lower value slows door down.
7	Latch Resistor	Governs latch speed of door. Resistor located on terminals 2 & 4 of terminal block. Terminal 1 being closest to edge of control.	
8	Check Speed Switch	Vary the back check speed	Fast position toward center of control
9	Mat Harness Connector	Interfaces the Activation, Safety and 24 VAC signals to the control	Black: Activation Signal Red: Common to Signal and 24 VAC White: Safety Signal Orange: 24 VAC
10	Safety Relay	Relay responsible for switching the Safety circuit	
11	Safety Selector Switch	Slide switch to select two safety modes	1. Standard Safe - Safety is ignored during opening cycle only 2. Swing Safe - Continuous Safety 3. Slide - DO NOT USE
12	Motor Protector Relay	Relay responsible for switch motor between high OPEN speed voltage and low CHECK speed voltage	This relay is not used with the GT-500 Standard Mode system. The relay is removed and a jumper is installed in its place.
13	Soft Start Capacitor Connectors	Used with GT300/400 and GT500 Optional Speed Units. <u>Not</u> used on GT-500 <u>Standard Mode</u> Control.	Leads should be connected together if a soft start capacitor is not used. Otherwise door will not open.

Wiring Connectors:

Refer to Figure 1. There are three connectors located on the control board. These are:

1. 120 VAC Connector

This is a three-pin connector with a mating connector installed. The 120 VAC Hot, Neutral and Ground connect to this plug

2. Activation Connector

This is a four-pin connector with a mating connector installed. The function of the wires on this connector are as follows:

- Black: Activation - Shorting this wire to Red common will open the door.
- Red: Common
- White: Safety - Shorting this wire to Red common will safety the door.
- Orange: 24 VAC - Connecting a load between this wire and Red common will apply 24 VAC to the load.

VAC

Figure 2 - Door Positions

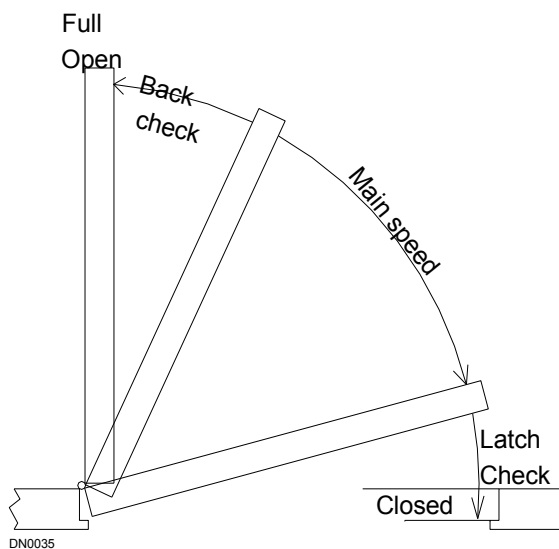

Terminology:

Back Check – This takes place from about the last 10° of sweep to the full open position.

Closing Speed – How fast the door moves from fully open to the final 10° before fully closed.

Latch Check–This takes place from about the last 10° of sweep to the full closed position.

Opening Speed – How fast the door opens from fully closed to approximately 80° open.

Time Delay Activation Signal – When the door is activated via a push plate, a mat, a sensor, etc., this option determines how long the door will stay open. It is adjustable up to 60 seconds.

Adjustments:

There are three slide switch adjustments on the Analog Control Board. Refer to Items 1, 8, and 11 in Figure 1. There are two switches that govern OPEN and CHECK speeds and one that controls when the safety signal on the White wire on the Mat Harness is acknowledged.

Notes:

The amount of energy stored in the door and imparted to an object on impact is determined by both the weight and speed of the door. NABCO ENTRANCES INC. recommends setting opening and closing speeds as slow as owners will accept, AND below the maximums stated by ANSI.

The settings on the controller will vary slightly as the voltage supplied to the unit varies due to fluctuations in building and electrical supply loads. To allow for variations, the manufacturer recommends adding 1 second to ANSI’s minimum opening or closing times. Use a stopwatch for assistance.

Micro switch Adjustments:

This section details the installation and adjustments of the Analog Control in a GT-300 and GT-400 swing door units.

Step 1: Install all components as per the applicable hardware installation manual.

Step 2: Connect all wiring and harnesses as per the following wiring diagrams as they pertain to wiring and adjustments for GT-300, GT-400, GT-500, and GT-600 Operators.

Back Check and Latch Micro Switches:

The operators used with the GT-300, GT-400 and GT-500's provide the necessary latch check and back check limit switches the Analog control requires for correct operation. These switches are mounted on the top of the operator assembly as illustrated in the Figure # 3 below.

Wiring for Rocker switch:

Rocker Switch (part # 10-3528) is available. Connect the red wire to the black on the Mat Harness connector, the white wire to Red common on the Mat Harness connector and the black wire to the normally open contact of the activation device. Refer to

FIGURE 3 - MICRO SWITCH CONFIGURATIONS

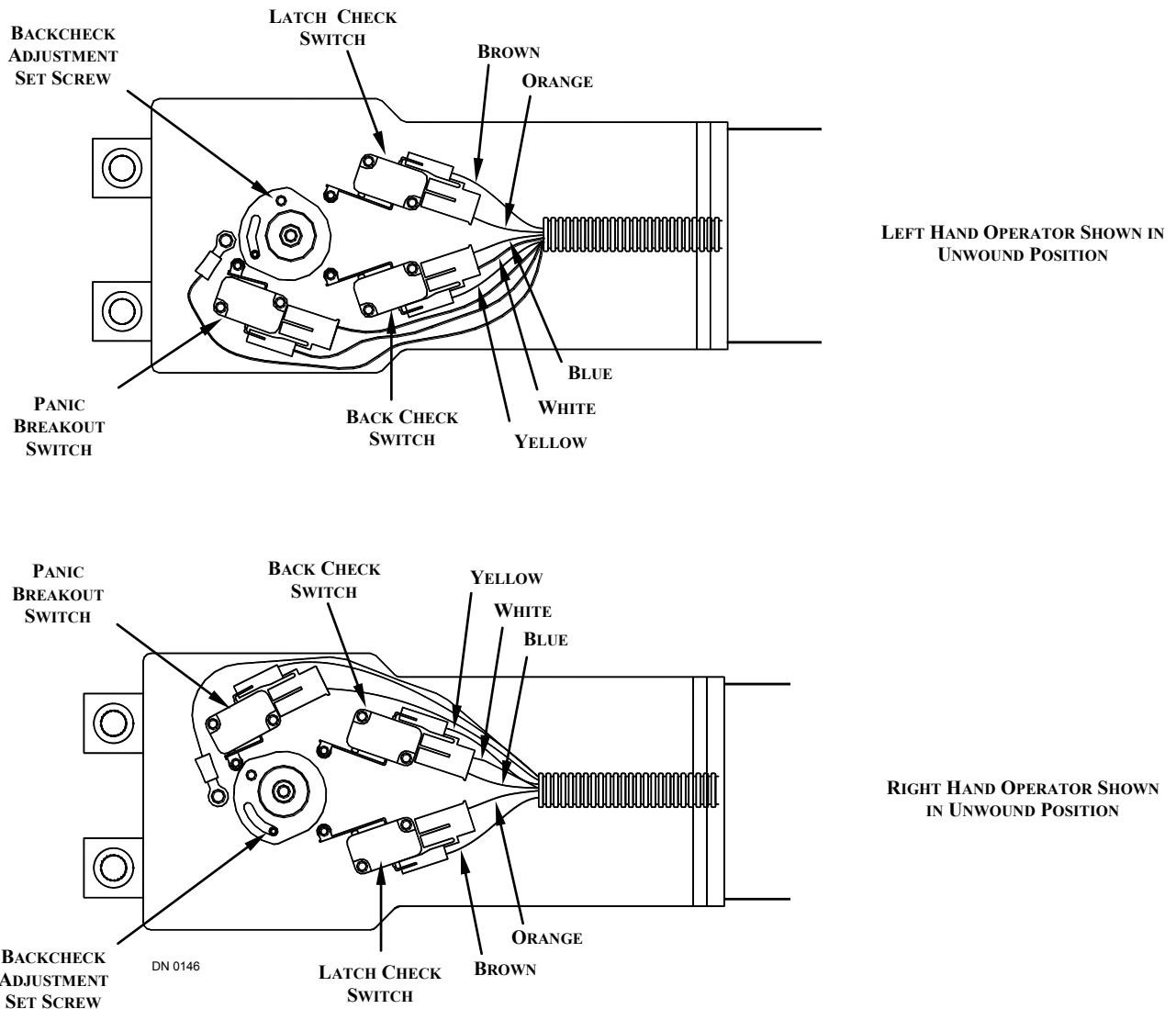

Wiring for Panic Break-out:

When the unit has a Break-out feature, the panic breakout circuit must be connected to shut down the system when the door is broken out in the opposite direction. This is done by opening the Red common circuit to the activation devices. Please refer to the following procedure.

- A Panic Latch must be installed. When installing the panic latch, the panic latch is installed so that the “ ← EXT” arrow points to Exterior side of the building. This makes the switch open when the door is broken out. See Figure 4 below.
- b. Plug the Red wire from the Mat Harness into the mating connector of the panic breakout switch. Plug the other connector on the panic breakout switch into the mating connector on one of the red wires going to the micro switch on the top of the operator. Connect the other Red wire from the micro switch to the various necessary points required for the common wire. Refer to the following diagrams.

**FIGURE 4
PANIC LATCH**

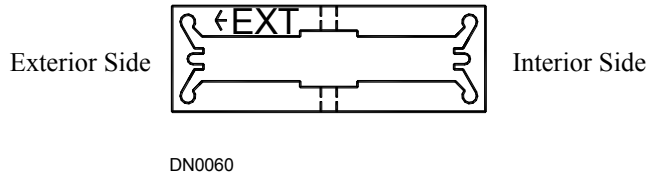

**FIGURE 5
BREAKOUT CIRCUIT
WIRING DIAGRAM**

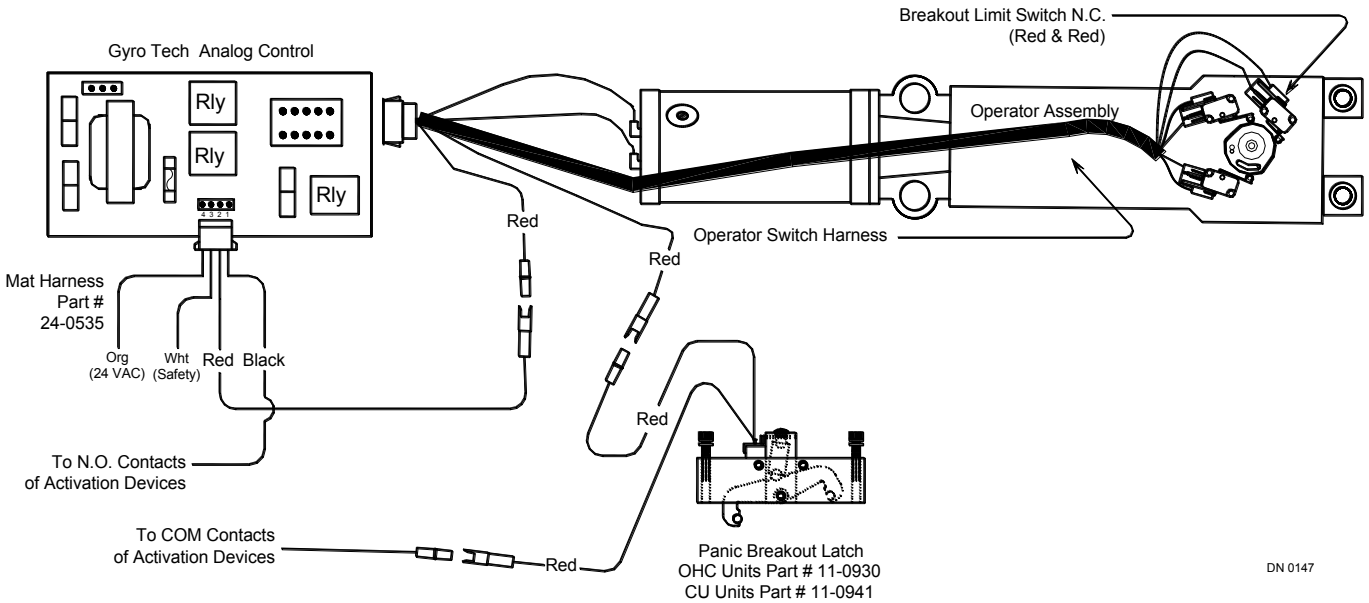

Required Wiring Harnesses:

See below for an illustration of some of the wiring harnesses that are necessary to complete a typical installation.

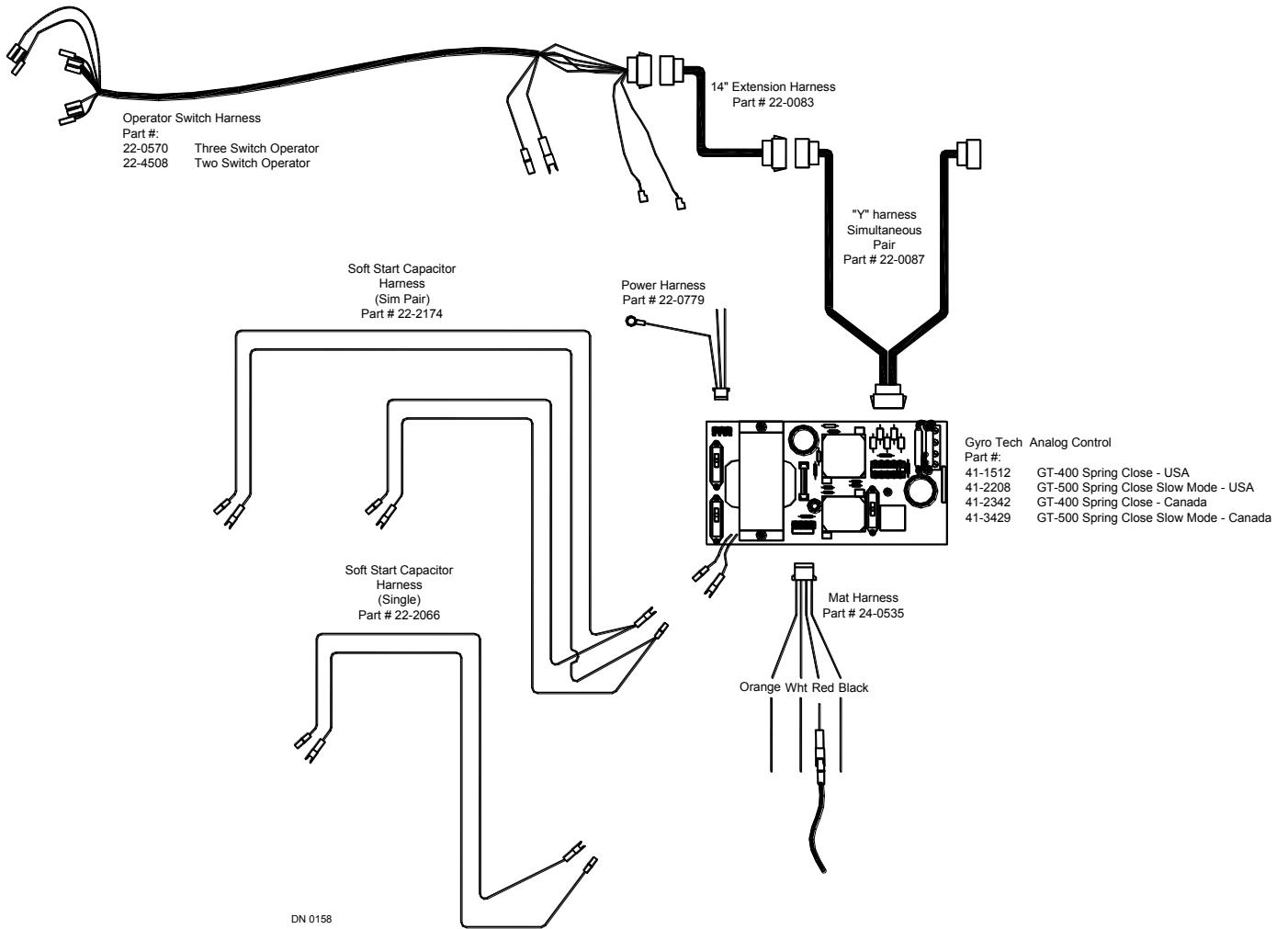
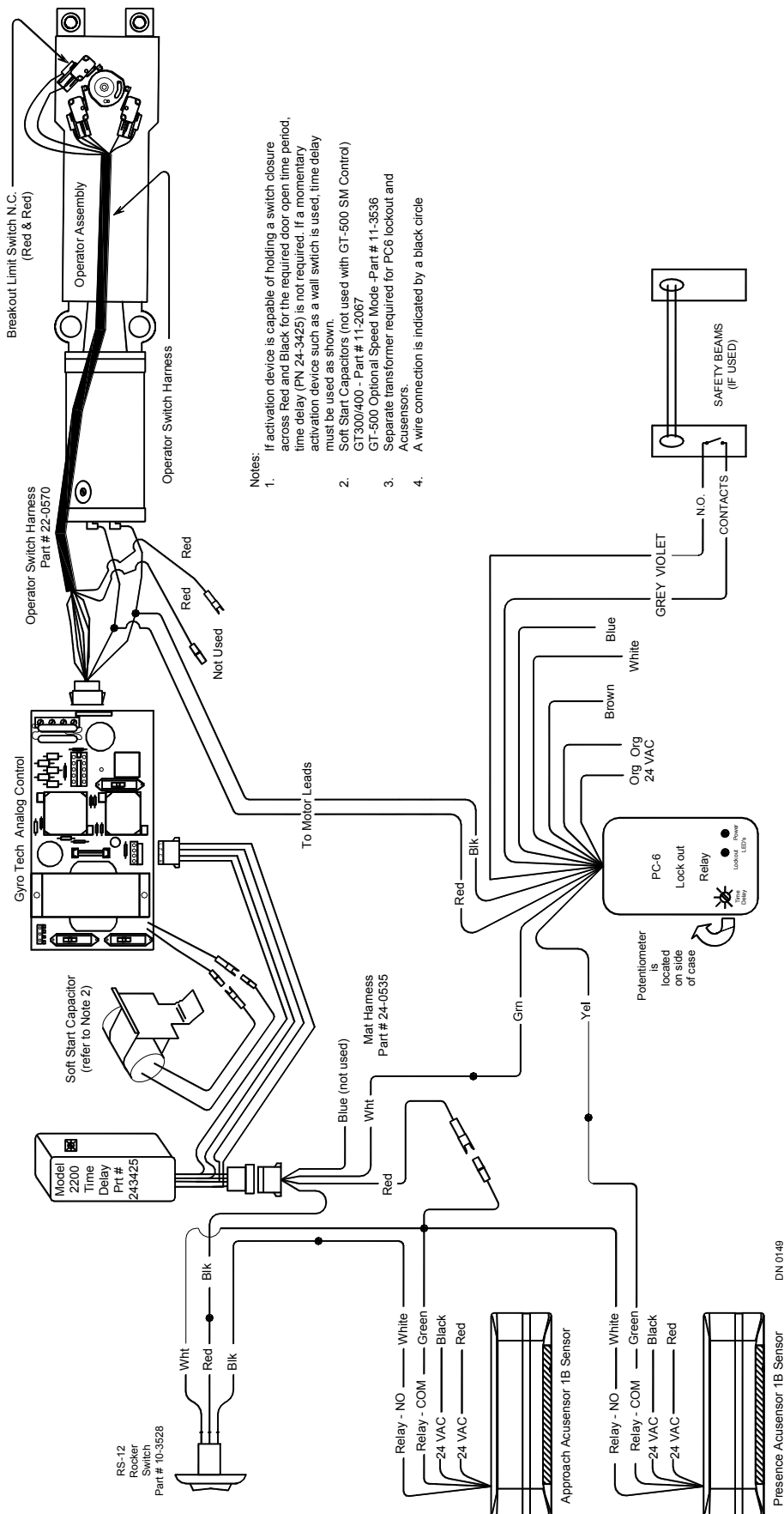

FIGURE 6 - WIRING HARNESSSES FOR MAGNUM IV

Section A
Sample Wiring Diagrams
for GT-300, GT-400 Full Automatic Installations

Page 11	Figure 6 - General Wiring - GT-300/400 Single Outswing
Page 12	Figure 7 - General Wiring - GT-300/400 Single Inswing
Page 13	Figure 8 - General Wiring – GT-300/400 Pair Outswing
Page 14	Figure 9 - General Wiring – GT-300/400 Pair Inswing



- Notes:
1. If activation device is capable of holding a switch closure across Red and Black for the required door open time period, time delay (PN 24-3425) is not required. If a momentary activation device such as a wall switch is used, time delay must be used as shown.
 2. Soft Start Capacitors (not used with GT-500 SM Control) GT300/400 - Part # 11-2067
 3. GT-500 Optional Speed Mode -Part # 11-3536
 4. Separate transformer required for PC6 lockout and Acusensors.
- A wire connection is indicated by a black circle

Figure 7 - General Wiring - GT-300/400 Single Outswing

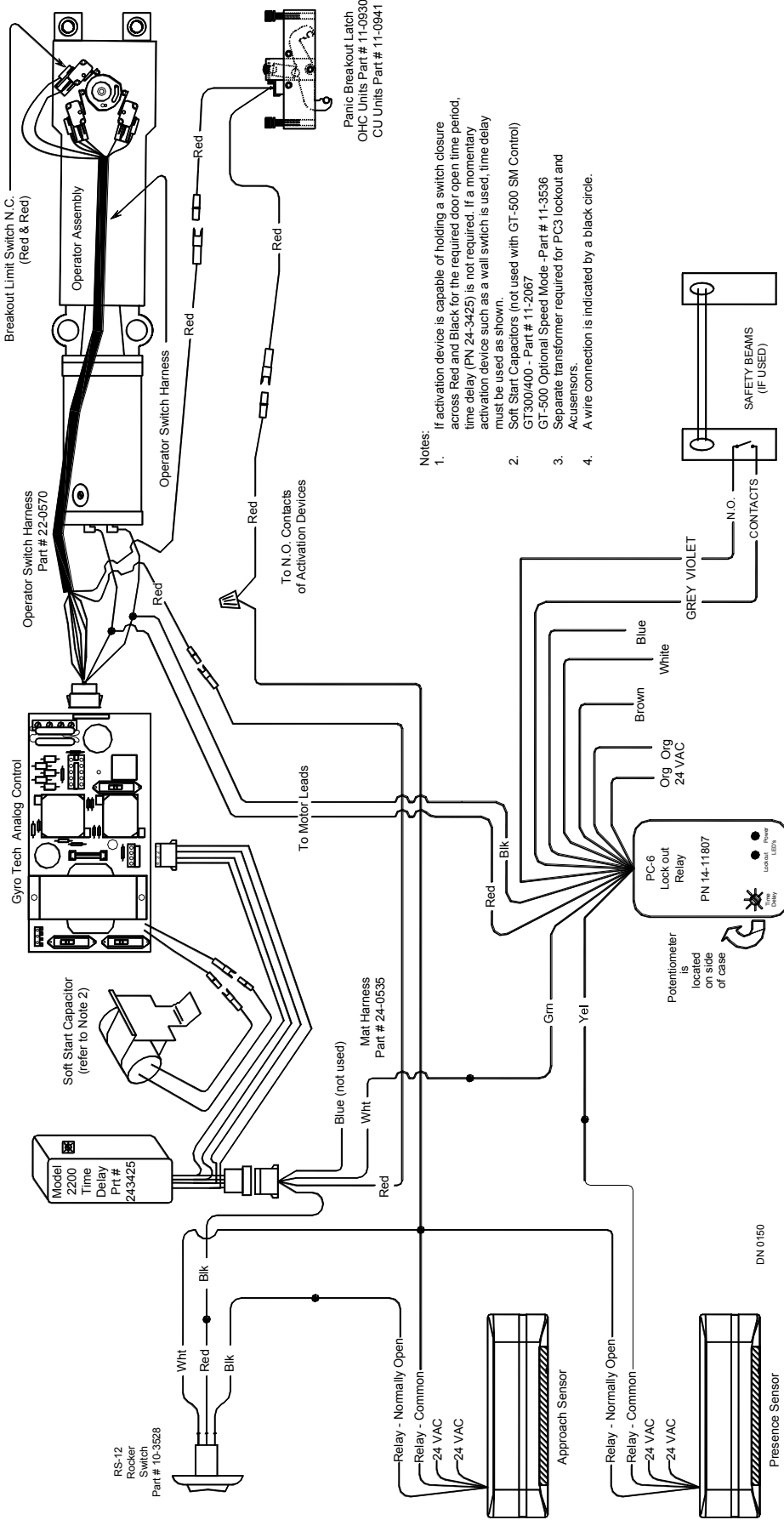

- Notes:
1. If activation device is capable of holding a switch closure across Red and Black for the required door open time period, time delay (PN 24-3425) is not required. If a momentary activation device such as a wall switch is used, time delay must be used as shown.
 2. Soft Start Capacitors (not used with GT-500 SM Control) GT3000/400 - Part # 11-2067 GT-500 Optional Speed Mode - Part # 11-3536
 3. Separate transformer required for PC3 lockout and Acusensors.
 4. A wire connection is indicated by a black circle.

Figure 8 - General Wiring - GT-300/400 Single Inswing

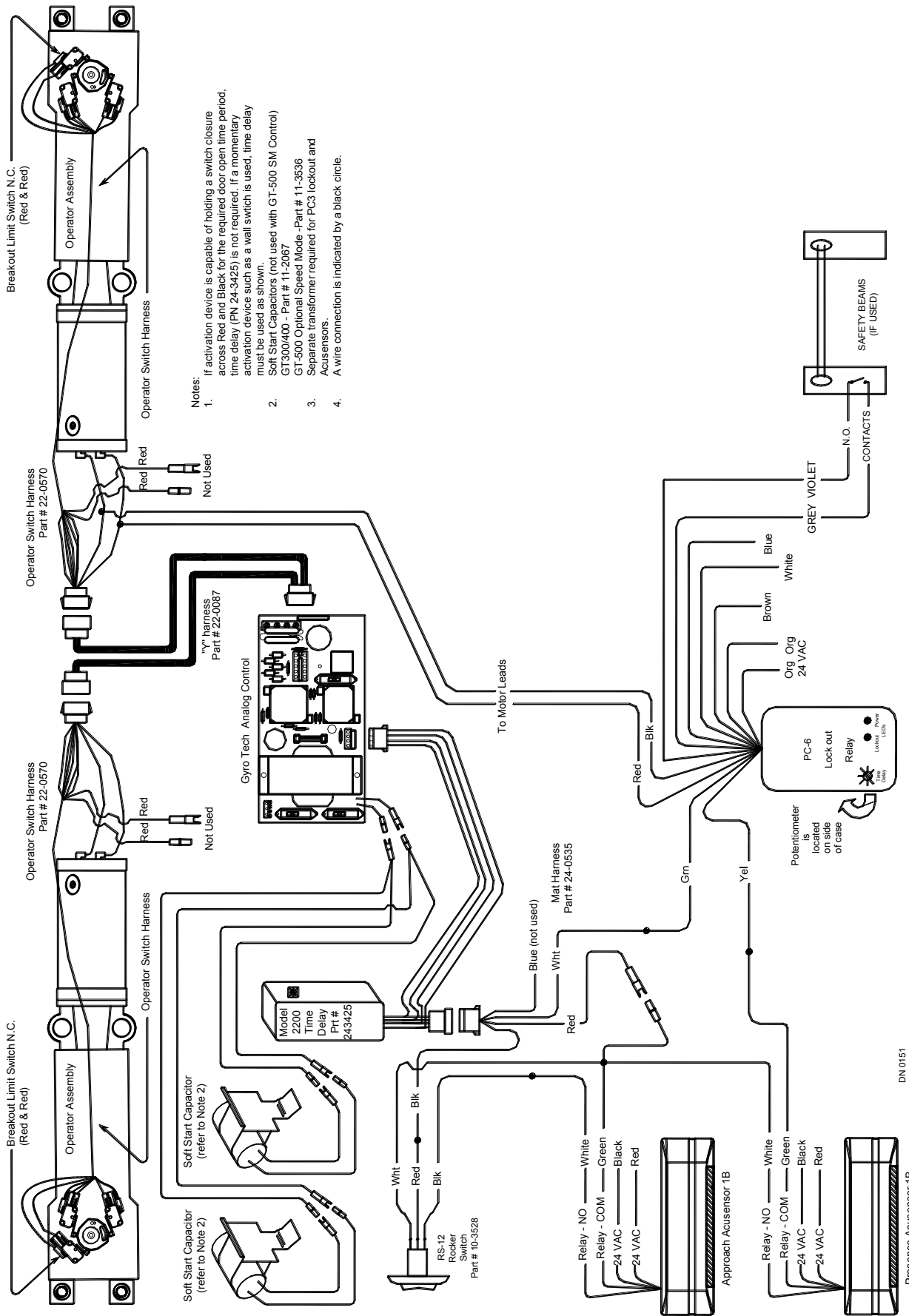
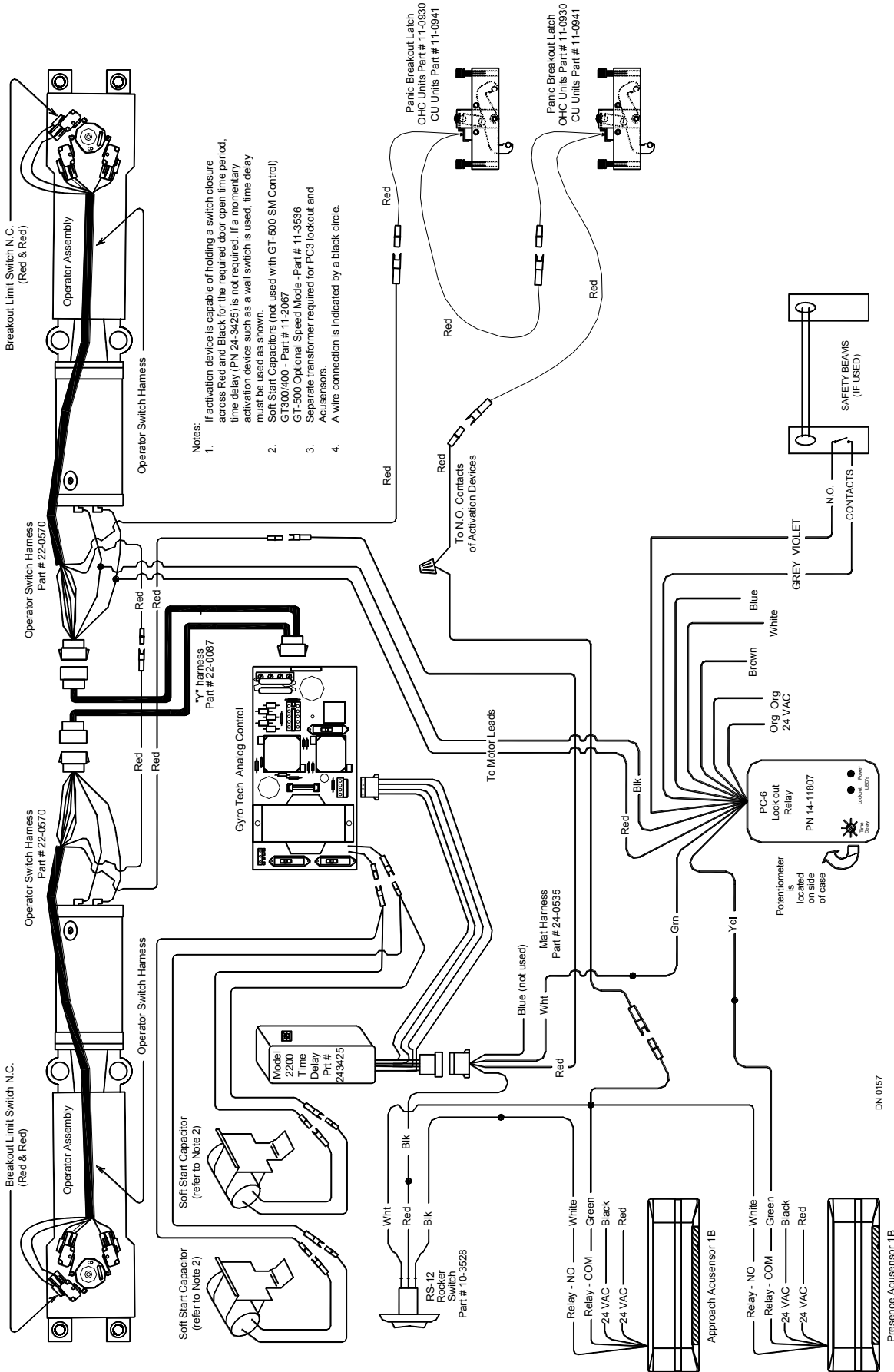

Figure 9 - General Wiring – GT-300/400 Pair Outswing



- Notes:**
1. If activation device is capable of holding a switch closure across Red and Black for the required door open time period, time delay (PN 24-3425) is not required. If a momentary activation device such as a wall switch is used, time delay must be used as shown.
 2. Soft Start Capacitors (not used with GT-500 SM Control) GT300/400 - Part # 11-2087
 3. GT-500 Optional Speed Mode - Part # 11-3536
 4. Separate transformer required for PC3 lockout and Acusensors. A wire connection is indicated by a black circle.

Figure 10 - General Wiring – GT-300/400 Pair Inswing

Section B
Sample Wiring Diagrams
for GT-500 Low Energy Installations

Page 16	Figure 10 - General Wiring - GT-500 Single Outswing
Page 17	Figure 11 - General Wiring - GT-500 Single Inswing
Page 18	Figure 12 - General Wiring – GT-500 Pair Outswing
Page 19	Figure 13 - General Wiring – GT-500 Pair Inswing
Page 20	Figure 14 - General Wiring - GT-500 with Electric Lock and Sequencer

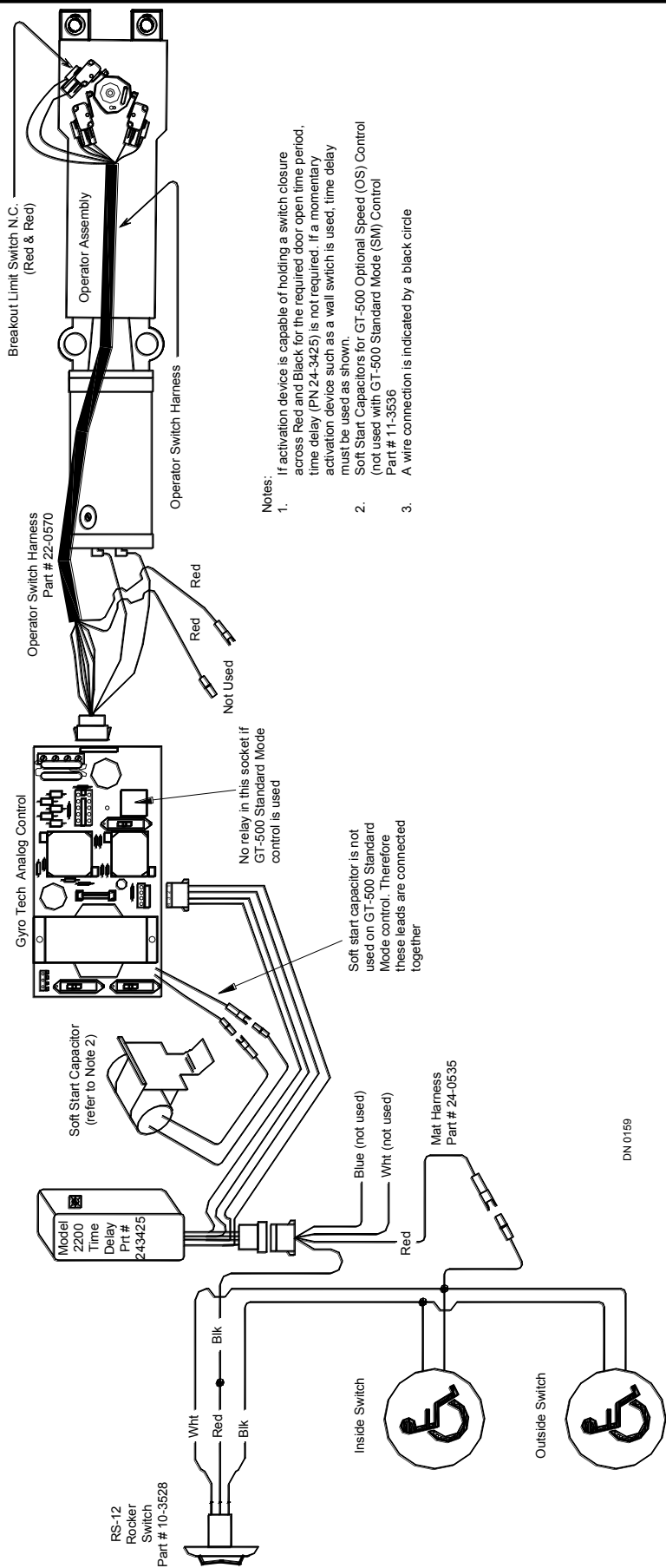

Figure 11 - General Wiring - GT-500 Single Outswing

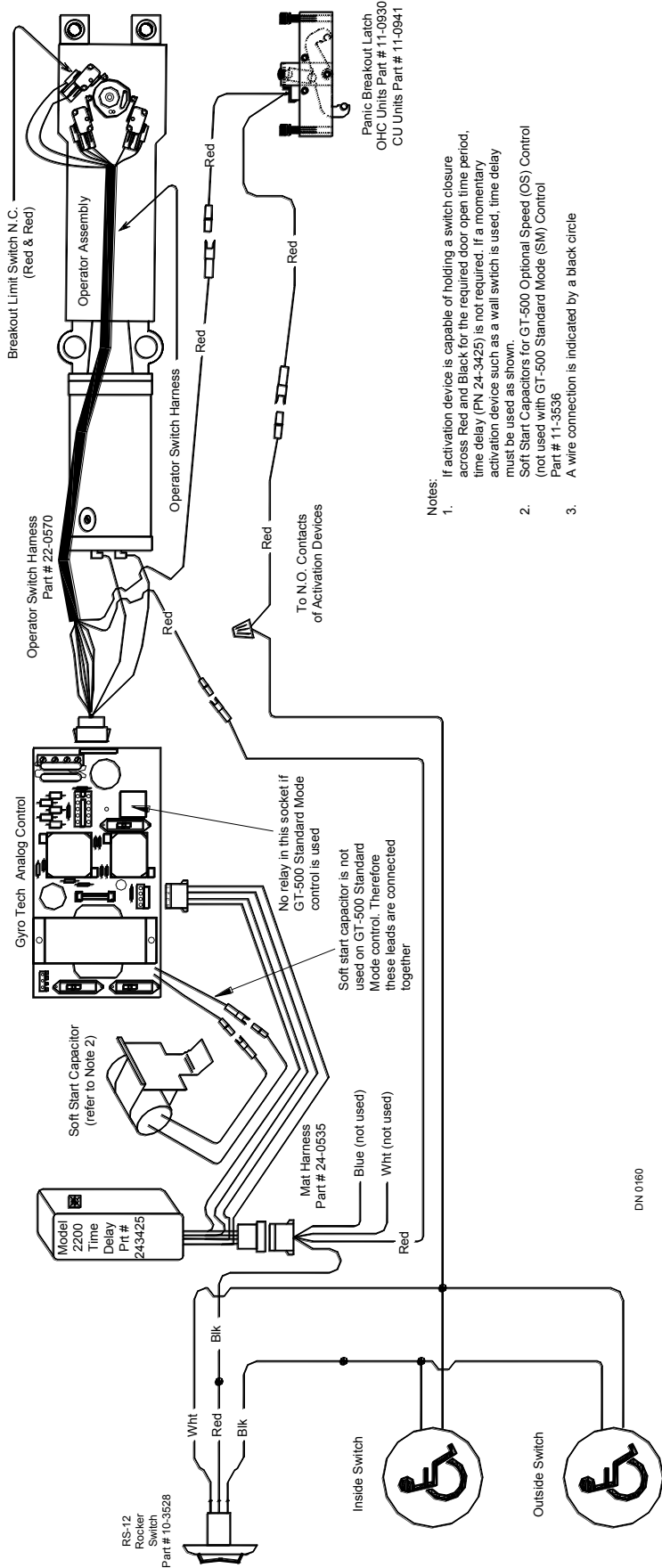

Figure 12 - General Wiring - GT-500 Single Inswing

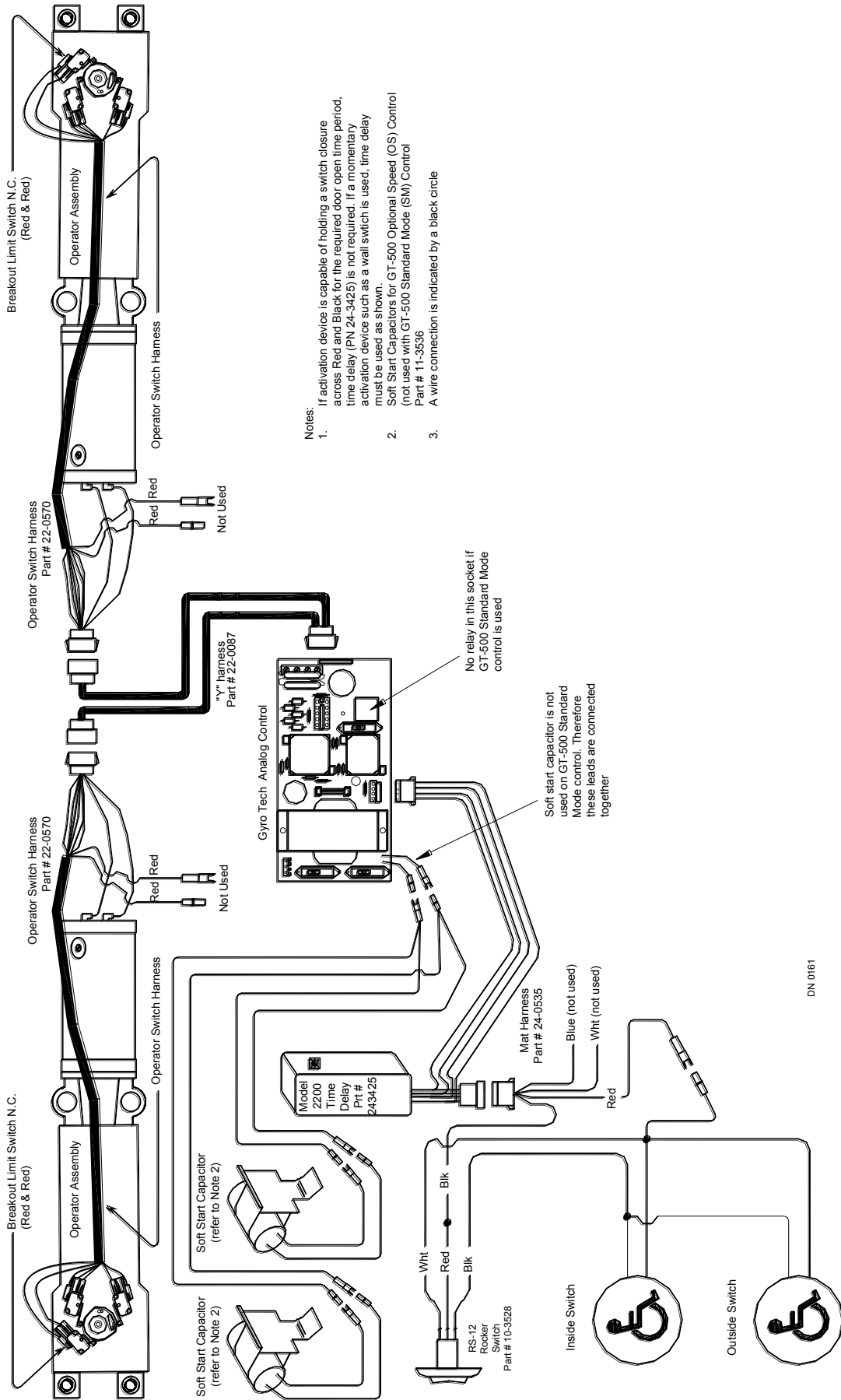

Figure 13 - General Wiring – GT-500 Pair Outswing

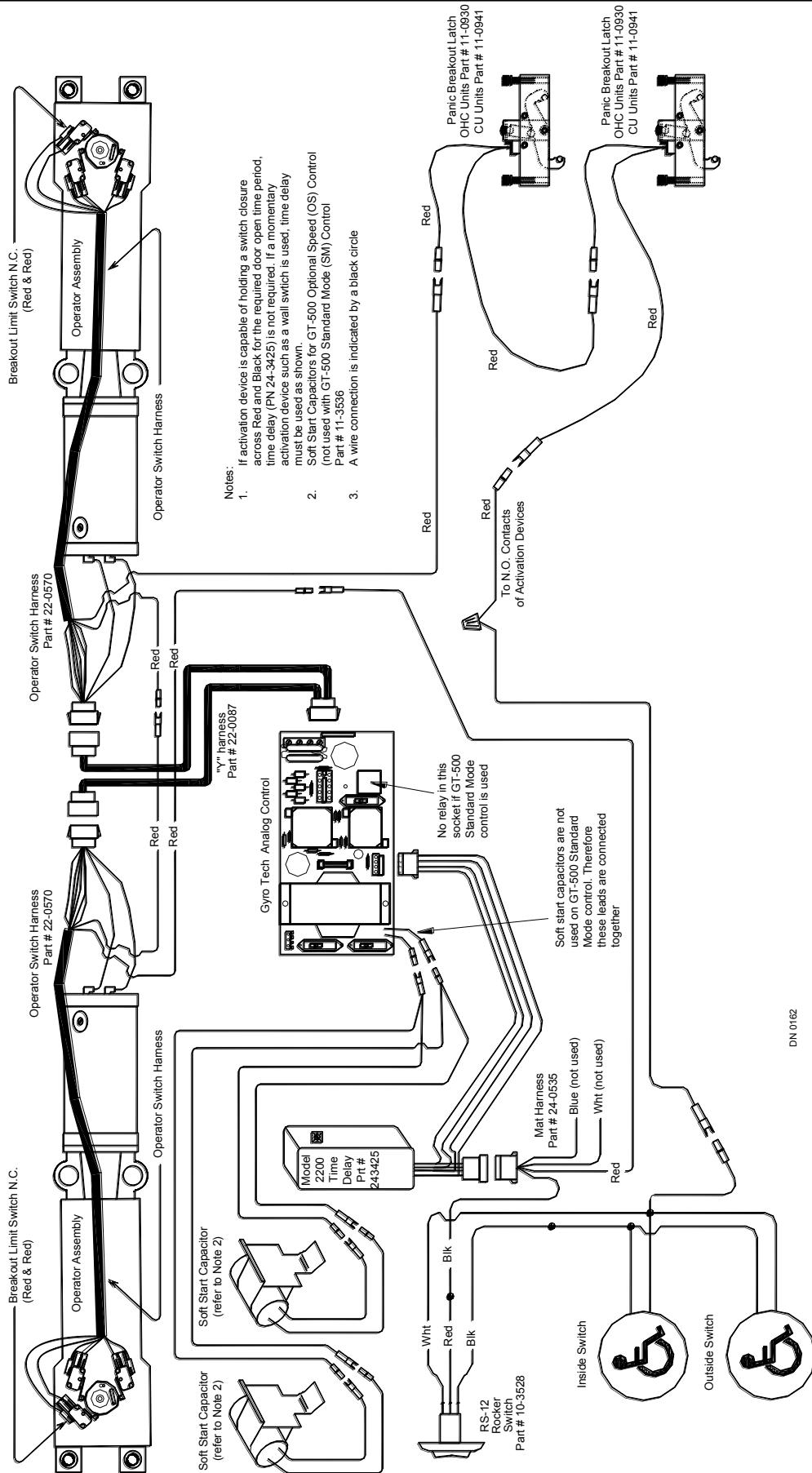
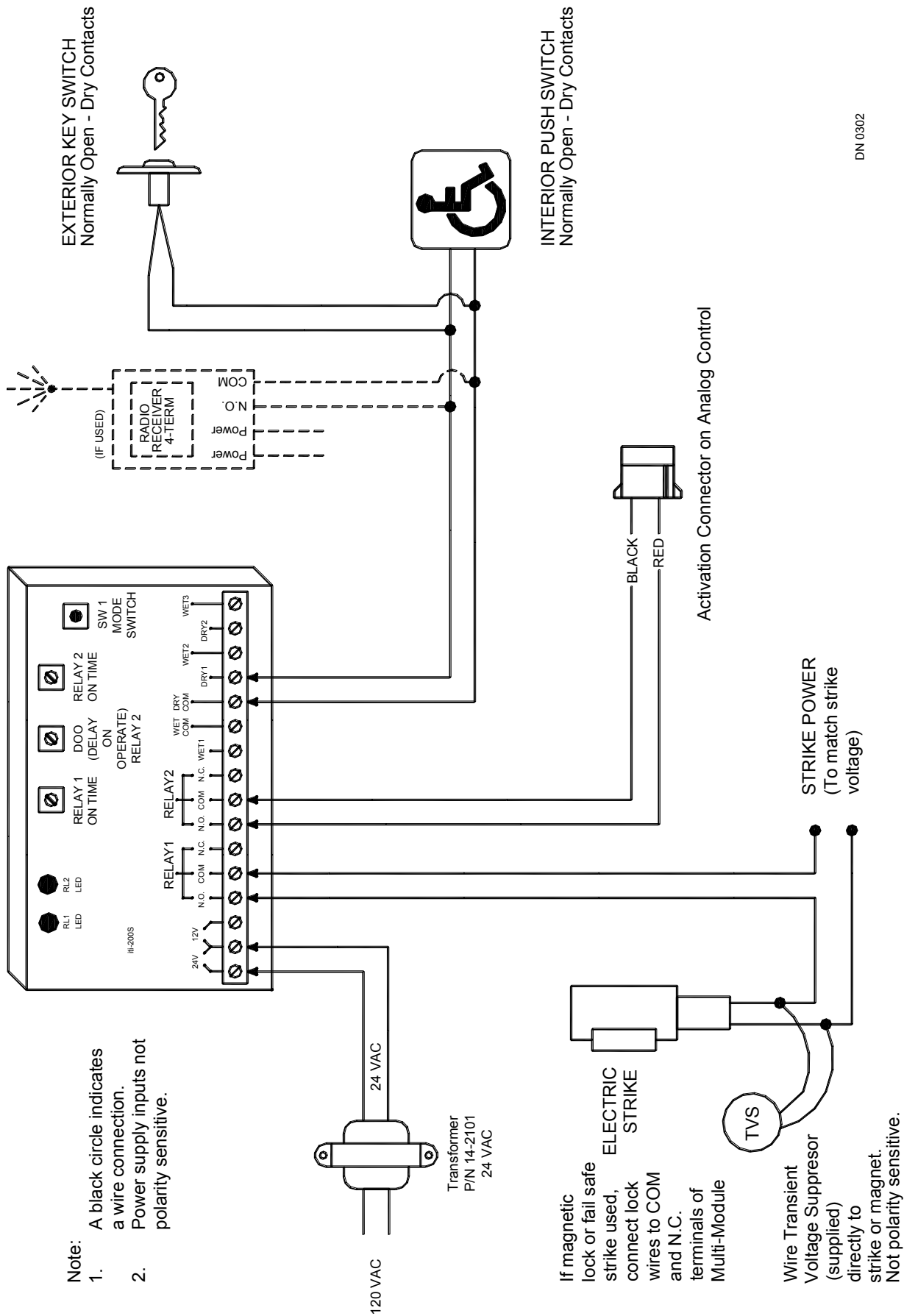

Figure 14 - General Wiring – GT-500 Pair Inswing



DN 0302

Figure 15 - GT-500 with Electric Lock & Sequencer

Troubleshooting:

Symptom	Action/Cause	Solution
Operator does not function	<ol style="list-style-type: none"> 1. Check Fuse 2 (F2). 2. Check for 120 VAC at connector J5 3. Check power to activation device at connector J1. 4. Check Fuse 1 (F1) 	<ol style="list-style-type: none"> 1. Replace fuse 2. Check incoming power. If power is good, check connection to motor. Replace motor if necessary 3. If power exceeds 0.5 amps at 24 VAC, replace with lower draw sensor. If blown, replace fuse. 4. If F1 is OK, check power to activating devices at J2. Voltage is too low, reduce accessory load
Adjustment of Hydraulic Closer has no effect. (GT-710 only)	Check 4 pin motor connector on the board	For GT-710's only: Pin #2 and #4 must be jumped by a wire
Door slams closed	<ol style="list-style-type: none"> 1. GT-710: Main speed on hydraulic closer not adjusted properly 2. GT300/400/500: Closing speed not adjusted or motor circuit open 	<ol style="list-style-type: none"> 1. Turn main speed in direction of turtle 2. Adjust closing speed on Magnum control 2. check for open connection on motor circuit
Door slams open	<ol style="list-style-type: none"> 1. All units: Back check speed not adjusted 2. GT-710: magnet not in proper location 3. GT-300/400/500: Operator not preloaded correctly 	<ol style="list-style-type: none"> 1. Adjust back check speed on hydraulic closer or Magnum control 2. Adjust back check potentiometer or relocate magnet 3. Pre-load operator by correctly installing arm on operator spindle as per hardware installation manual
Fuse 2 (F2) blows when door open is triggered	Check door activation device power consumption	If power draw exceeds 0.5 amps at 24 VAC, replace with lower draw sensor
Motor spins when activated but door does not open	<ol style="list-style-type: none"> 1. GT-500: Check polarity of motor input wires at connector on motor 2. All units: motor/operator coupling or spyder coupling loose between motor and operator 	<ol style="list-style-type: none"> 1. Reverse motor leads on motor 2. Remove and separate motor and operator. Inspect couplings for looseness
Back check adjustment on Magnum board has no effect	<ol style="list-style-type: none"> 1. GT-710: The fully open door position is greater than 90° and the back check adjustment on the hydraulic closer is overriding the controls of the Magnum board 2. All units: Door is not going into back check even though it is reaching 90 degrees 	<ol style="list-style-type: none"> 1. Adjust the back check screw on the bottom of the header out one turn 2. Reposition magnet on GT-710 or correctly pre-load arm on GT-300/400/500 as per hardware installation manual
No back check	<ol style="list-style-type: none"> 1. GT-710: Magnets on main sprocket not in correct position. 2. GT-300/400/500: back check switch not closing at correct position 	<ol style="list-style-type: none"> 1. Follow instructions in GT-710 hardware installation manual to properly align magnets. 2. Follow instructions in GT-GT300/400/500 hardware installation manual to properly pre-load operator
Door does not stay tightly closed	<ol style="list-style-type: none"> 1. All units: Preload on swing arm is not correct 2. GT-710: Spring adjustment not correct on LCN closer. 3. GT-710: Building stack pressure is excessive 	<ol style="list-style-type: none"> 1. Position arm as shown in hardware installation manual 2. Adjust spring tension on LCN closer as per GT-710 hardware installation manual. 3. Upgrade operator unit to GT 500

Troubleshooting **continued**

Symptom	Action/Cause	Solution
Presence Sensor does not function	1. All units: No power to sensor or defective sensor. 2. All units: Sensor not connected to White wire	1. Check harness wiring as per applicable section 2. Connect the output of the sensor to the Red # 5 and White # 4 connections on the terminal block.
Swing Side Door sensor does not function	1. All units: No power to sensor or defective sensor. 2. All units: Sensor not connected to Violet wire	1. Check harness wiring as per applicable section. 2. Connect the output of the sensor to the Red # 5 and Violet # 3 connections on the terminal block
Swing Side Presence Sensor is activated by opening or closing door	All units: Connection of sensor to wiring harness was to "Safety" not "Safety w/ Lockout"	Rewire Safety Sensor to "Safety w/Lockout" connector. (pins Red # 5 and White # 4 connections on the terminal block.)
Swing Side ACUGARD 2, swing side floor mat, safety holding beams or other accessories do not function while door is moving	All units: Connection of accessories was made to "Safety w/Lockout" not "Continuous Safety"	Rewire accessory to "Continuous Safety" connection (Red # 5 and Violet # 3 connections on the terminal block.)
Sensor shows activation signal sent, but door does not open	All units: Sensor not connected properly to activation connector	Check harness wiring as per applicable section
One sensor does not activate both doors on a simultaneous pair	All units: Sensor is not connected to both control boards	Install simultaneous pair harness (P/N 229953)

DO NOT PRINT THIS PAGE !!
PART NUMBER 15-10745
ANALOG CONTROL MANUAL
~ CHANGE LOG ~

Rev 3-25-05 to 8-13-09

1. Removed PO Box info on front page
2. Replaced logo on first page
3. Replaced Figure 7
4. Replaced Figure 8
5. Replaced Figure 9
6. Replaced Figure 10
7. Replaced Figure 15
8. Corrected Figure number sequences